

Aluminum Spacer Bracket (Models ASB-32, ASB-62, and ASB-82) Installation Instructions

INTRODUCTION

The Aluminum Spacer Bracket (ASB) is a 1/2" [12.7 mm] thick, anodized, aluminum spacer bracket with individual designs for the Models M32, M62, or M82 Magnalocks® (see Figure 1, "ASB Group"). Installations in aluminum frame glass doors with or without blade stops may require an ASB, which improves frame mounting strength, Magnalock/Strike clearances, alignments, and also eases installation (see Figure 2, "Installation Cross Section").

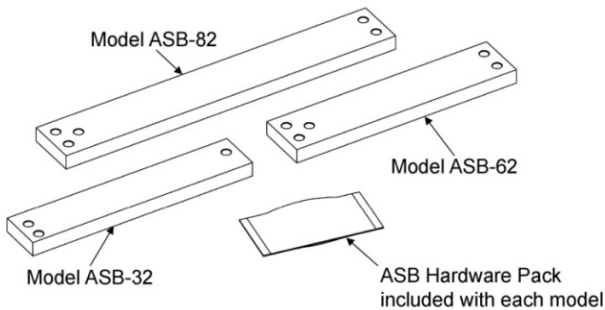

Figure 1. ASB Group

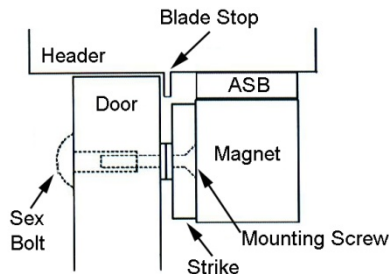

Figure 2. Installation Cross Section

RECOMMENDED INSTALLATION TOOLS

- Power Drill
- 3/8" [9.53 mm], 27/64" [10.72 mm] Drill Bits
- 1/2" Wrench or Adjustable
- Center Punch
- 3/16" Hex Wrench

INSTALLATION

Mounting the Strike

1. Prior to proceeding, DETERMINE the proper location for mounting the strike in relation to the Magnalock, and CONSIDER the following:
 - Aluminum-frame, glass doors vary depending on the top rail (shoe) size and the internal structural design.
 - In a narrow frame, once the Magnalock is spaced down by the ASB, it may not be possible to install the sex bolt for the strike without hitting glass or an internal structure (e.g., cable); therefore, supplied hardware with the ASB allows the strike to be directly mounted to the door using a special 5/16-18 [8 mm-1.5 mm] threaded blind nut.
2. **IF** mounting the strike on a conventional frame rail, **AND** the use of an ASB is required, **THEN MOUNT** the strike using a sex bolt and as described in the applicable Magnalock instructions.
3. **IF** mounting the strike on a aluminum-frame, glass door, **AND** the use of an ASB is required, **THEN PERFORM** the following.
 - a. DRILL a 1/4" starter hole into the door in the location where the sex bolt would normally be used.
 - b. INSPECT for any structural door component that might interfere with the use of a sex bolt (e.g., cable or bar).
 - c. **IF** there are no structural door components in the way, **THEN MOUNT** the strike using the sex bolt and as described in the applicable Magnalock instructions.

NOTE: When properly collapsed, a special blind nut provides adequate security for the strike in an aluminum-framed, glass door.

 - d. **IF** there are structural door components in the way, **AND** the use of a sex bolt is not feasible, **THEN MOUNT** the strike on the door using a special blind nut and mounting screw.

Mounting the Strike using a Special Blind Nut and Mounting Screw

NOTE: Figure 3, "Blind Nut Components," and Figure 4, "Special Blind Nut Installation," provide illustration for the following steps.

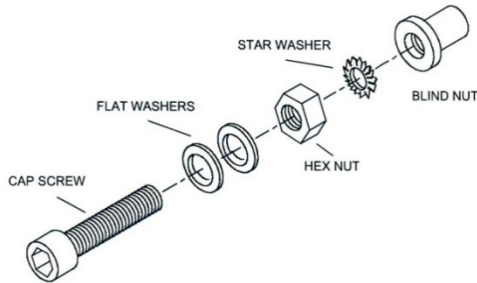

Figure 3. Blind Nut Components

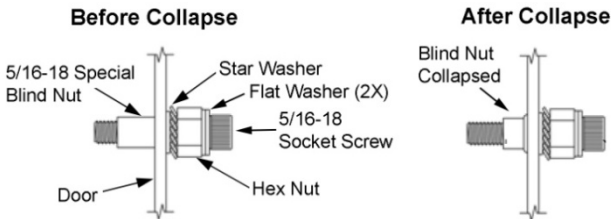

Figure 4. Special Blind Nut Installation

1. DRILL the marked mounting hole location in the door using a 27/64" [10.72 mm] drill bit.
2. THREAD the additional hardware into the 5/16-18 cap screw, as shown in Figure 3.
3. INSERT the 5/16-18 [8 mm-1.5 mm] blind nut fully into the mounting hole.
4. INSERT the 5/16-18 cap screw with additional hardware into the special blind nut.

NOTE: Use of a lubricant on the blind nut threads is required to keep the assembly from spinning and not collapsing.

5. Using a box wrench to hold the hex nut in position, TURN the cap screw with an Allen Wrench 3 to 4 complete turns to collapse the blind nut.
6. REMOVE the cap screw
7. POSITION and MOUNT the strike onto the door.
8. TIGHTEN the cap screw to secure the strike to the door.

Mounting the ASB and Magnalock

NOTE: Figure 5, "ASB and Magnalock Installation," provides illustration for the following steps.

1. MARK the cable access hole and the mounting holes where the 1/4-20 blind nuts will be located using the provided Magnalock template, and CENTER PUNCH.
2. DRILL a 1/8" or 1/4" starter hole.
3. DRILL the marked mounting hole locations in the frame using a 3/8" [9.53 mm] drill bit.
4. DRILL the marked hole for the cable access into the frame as indicated on the provided Magnalock template.

NOTE: Socket head cap mounting screws are provided in the ASB hardware package and the washers are provided in the applicable Magnalock hardware package.

5. THREAD the additional hardware onto each 1/4-20 cap screw, as shown in Figure 3.
6. INSERT each 1/4-20 blind nut fully into a mounting hole.

NOTE: Use of a lubricant on the blind nut threads is required to keep the assembly from spinning and not collapsing.

7. One by one, and using a box wrench to hold each hex nut in position, TURN each cap screw with an Allen Wrench 3 to 4 complete turns to collapse its blind nut.
8. REMOVE the cap screws.
9. POSITION the Magnalock and cable onto the ASB bracket.
10. MOUNT the Magnalock and ASB assembly onto the frame.
11. INSERT and securely TIGHTEN the cap screws.

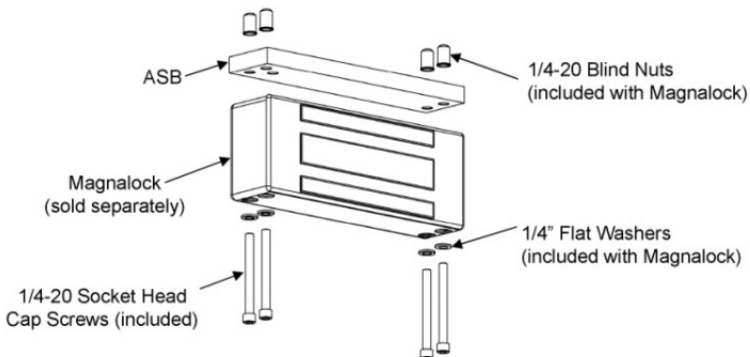

Figure 5. ASB and Magnalock (M62 shown) Installation