



911000-00

XP98/XP99

VON DUPRIN®

Rim Exit Device

Installation Instructions

Devices covered by these instructions:

- XP98/XP99 Rim Exit Device
- XP98-F/XP99-F (Fire) Rim Exit Device
- CDXP98/CDXP99 (Cylinder Dogging) Rim Exit Device

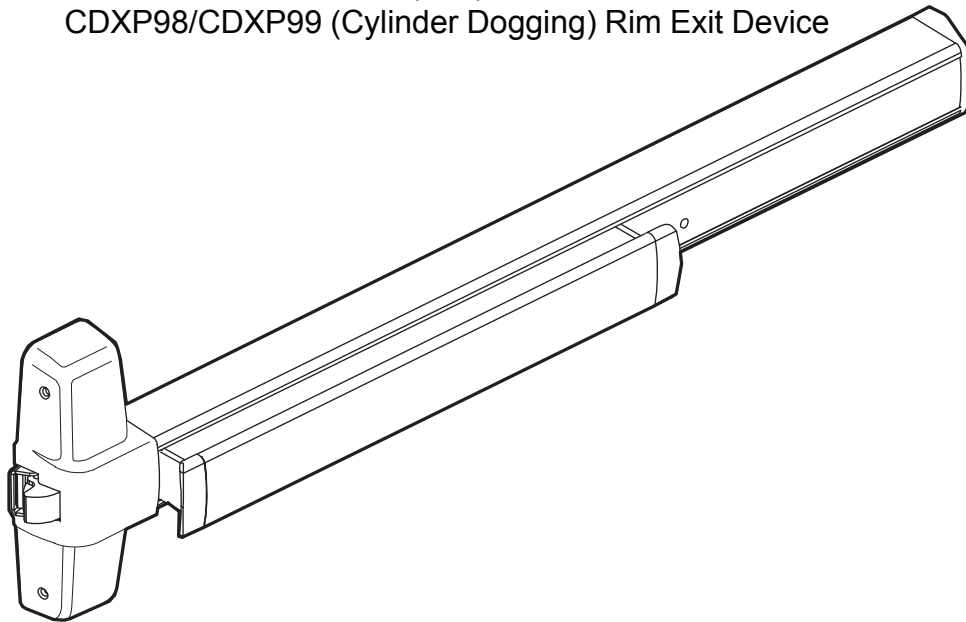

Please give these instructions to building owner after device is installed

Special tools needed:

Taps: #10-24, 1/4"-20

Drill bits: #7, #25, 1/8", 1/4",
5/16", 3/8", 13/32"

Index:

- Screw chart 2
- Preparation chart 3
- Device installation 4-6
- Retrofit installation 7
- Hex dogging information 8
- CD (cylinder dogging) 9
- Cut device 10
- 954 strike installation 10

SCREW CHART

A 909 Strike

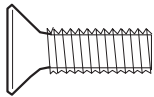
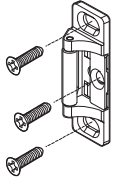

1/4"-20 X 3/4" (3 qty)

Metal frame

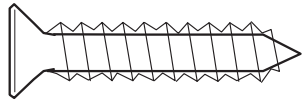

#14 X 1-1/2" Wood screw (3 qty)

Wood frame

B 954 Strike

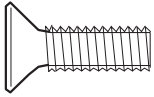
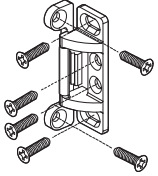

1/4"-20 X 3/4" (6 qty)

Metal frame

C

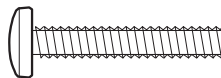
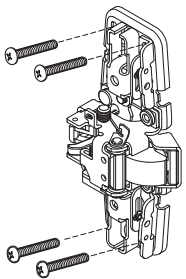

#10-24 X 1" (4 qty)

Surface mount or Sex bolts (1-3/4" door)



#10-24 X 1-1/2" (4 qty)

Sex bolts (2-1/4" door)

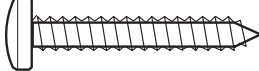

#10 X 1-1/4" Wood screw (4 qty)

Surface mount (wood)

- Packaged with trim -

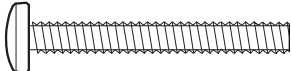

#10-24 X 1-3/8" (4 qty)

990 Trims (1-3/4" door)

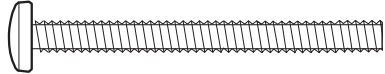

#10-24 X 1-7/8" (4 qty)

990 Trims (2-1/4" door)

D

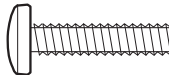
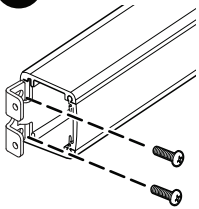

#10-24 X 3/4" (2 qty)

Surface mount or Sex bolts (1-3/4" door)

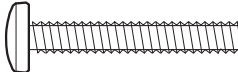

#10-24 X 1-1/8" (2 qty)

Sex bolts (2-1/4" door)

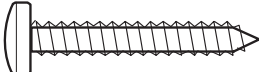

#10 X 1-1/4" Wood screw (2 qty)

Surface mount (wood)

E

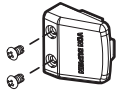

#10-16 X 3/8" Thread cutting (2 qty)

End cap screw

F

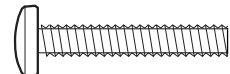
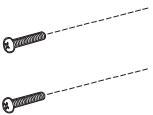

#10-24 X 1" (2 qty)

Surface mount (metal)

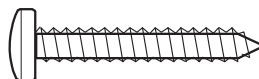

#10 X 1-1/4" Wood screw (2 qty)

Surface mount (wood)

G

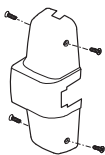

#8-18 X 3/8" Thread cutting (4 qty)

Cover screw

PREPARATION CHART

Go to "Device Installation" on next page before using this preparation chart

*End cap bracket - 2 holes

Surface mount		Sex bolts	
Metal	#25 Drill	Metal	1/4" Drill (device side)
	#10-24 tap	Metal	13/32" Drill (trim side)
Wood	1/8" Drill pilot 1" deep	Wood	13/32" Drill thru

*Prepare holes after center case is mounted and device is leveled



Center case - 4 holes

Surface mount		Sex bolts or 990 trims	
Metal	#25 Drill	Metal	1/4" Drill (device side)
	#10-24 tap	Metal	13/32" Drill (trim side)
Wood	1/8" Drill pilot 1" deep	Wood	13/32" Drill thru

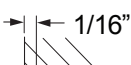
Center case - 2 support holes

Metal	#25 Drill #10-24 tap
Wood	1/8" Drill pilot 1" deep
For XP98-F/XP99-F (fire) wood door	
#825 Sex bolts (2) required	
Wood or composite	3/8" Drill thru 
	5/8" Spade drill
	1/16" Deep outside

Door cut-outs

	Outside cylinder applications: Mark with template and cut-out: Metal door (cut device side) Wood door (cut thru)
	For trim applications with working lever, thumbpiece, or knob: Mark with template and cut out: Metal door (cut device side) Wood door (cut thru)

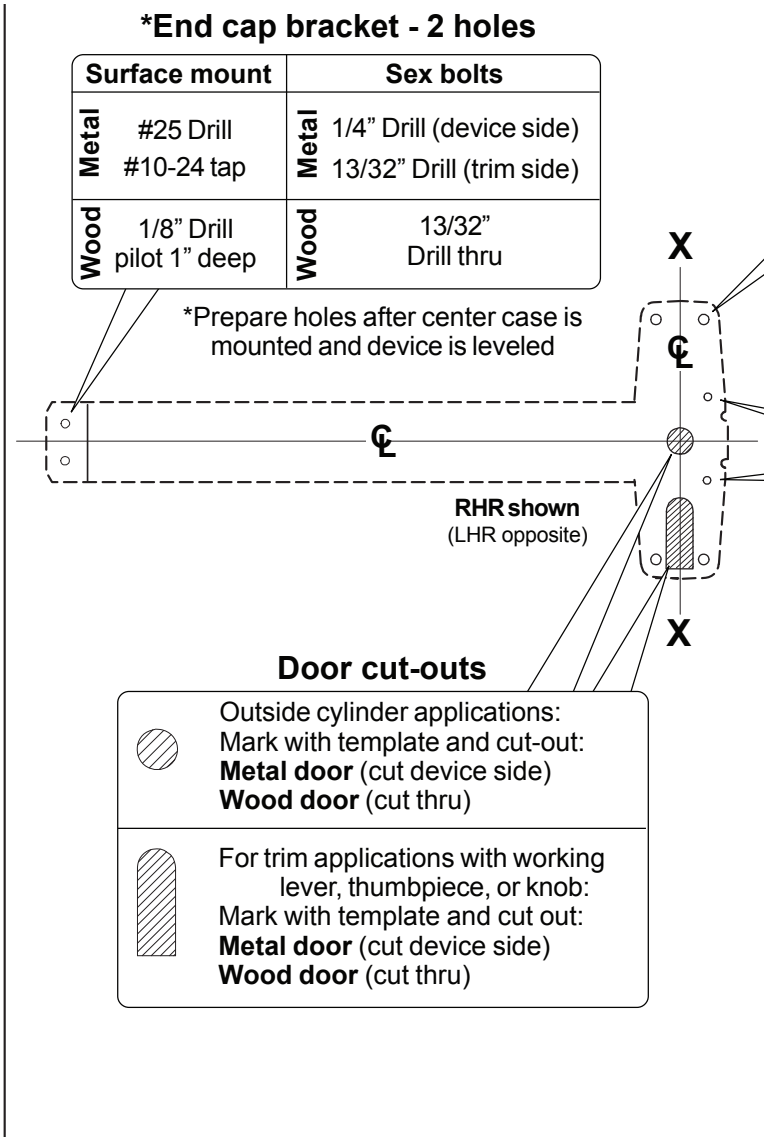

DEVICE INSTALLATION

Note: For retrofit applications where an existing 98/99 Rim device is being replaced, see “Retrofit Installation” on page 7.

1

Draw horizontal device and strike center line (☉).

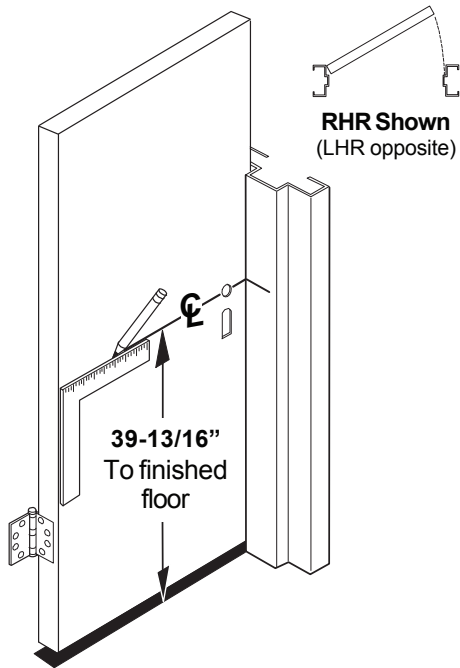

2

Align strike on ☉ and mark the two outer slots.

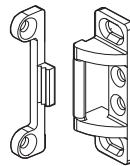
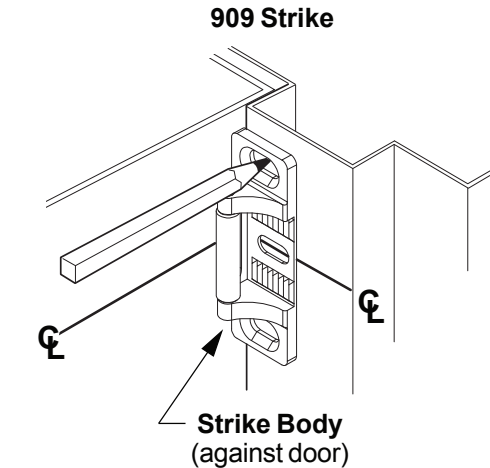

For 954 strike, see page 10

3

Prepare holes thru center of 2 outer slots and install screws.

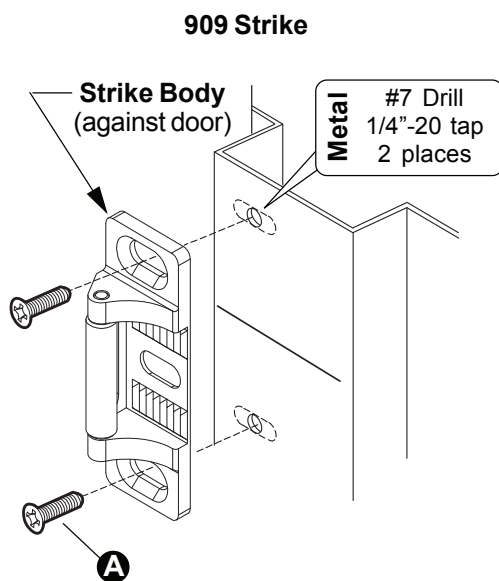

See “Screw Chart” on page 2 for screw type and size

4

Position template against strike and on ☉ and mark door.

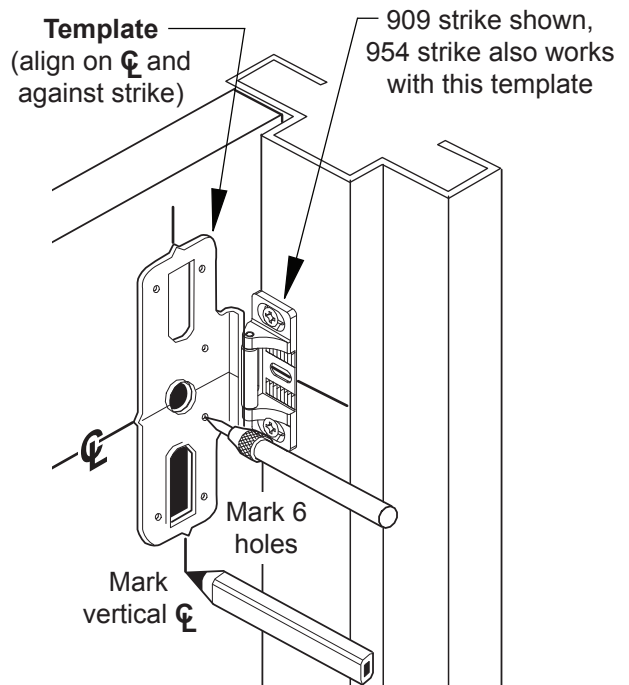

5

Prepare lock side of door for device and trim.

See "Preparation Chart" on page 3 for drill, tap, and cut-out information

See trim instructions for pull side door preparation. Line X-X in trim instructions is same as vertical device .

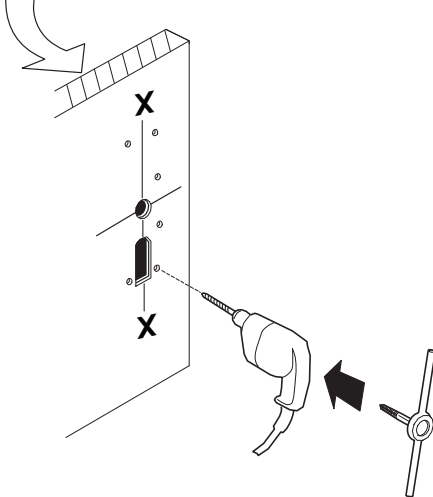

7

Secure device center case to door and install trim (if using).

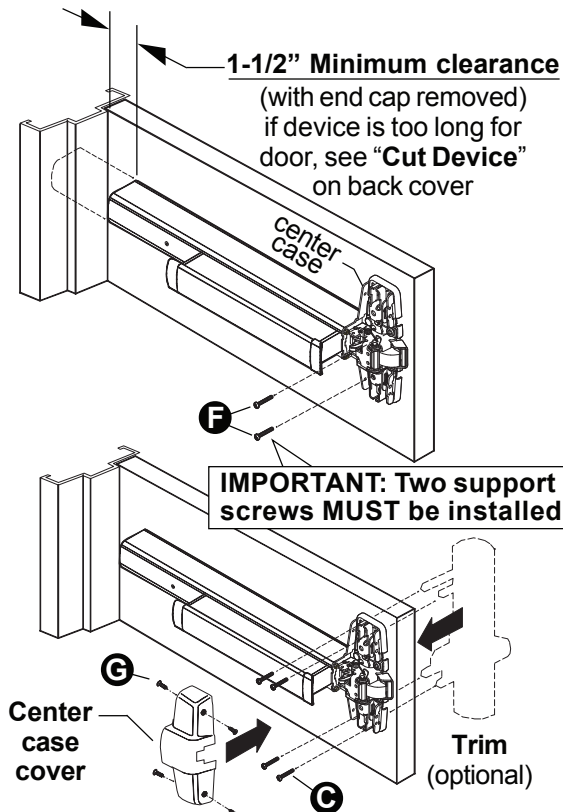

6

If Necessary, Remove NL Drive Screw

NL drive screw
Factory installed on back of center case

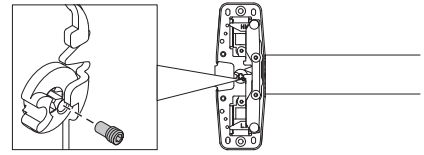

With NL drive screw removed, key locks and unlocks lever, knob, or thumb piece. For trims listed below, **REMOVE** NL drive screw.

996L	696TP	990TP
996K	697TP	

With NL drive screw installed, key retracts latch bolt. **DO NOT** remove NL drive screw for the following applications:

NL, EO, DT trims and 98/99-2 double cylinder devices (i.e. TP-2, L-2, and K-2).

*996L-BE	*E996L	*696TP-BE	*990TP-BE
*996K-BE	*E996L-BE	*697TP-BE	

*If trim being installed is "BE" (i.e. 996L-BE), trim lock tumbler on back of device must be in **UP** position before device is installed. This allows trim to be unlocked at all times.

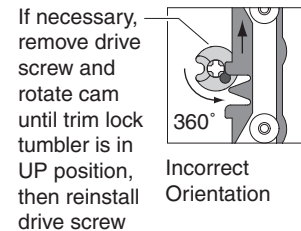
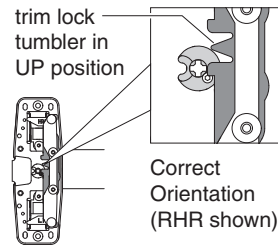

8

Install mounting bracket and end cap.

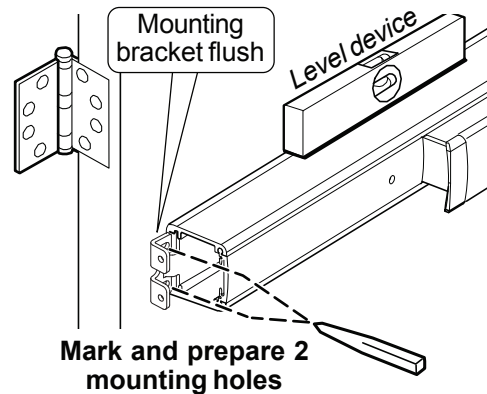

See "Preparation Chart" on page 3 for drill and tap sizes

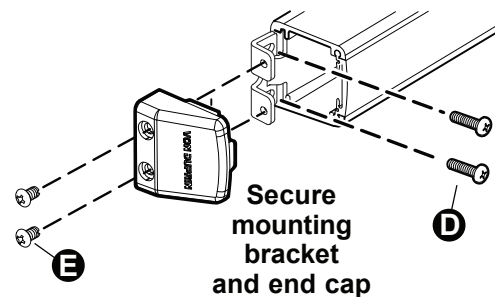

9

IMPORTANT!

Verify gap between latch bolt and strike and adjust strike as needed.

Strike **MUST** have some gap

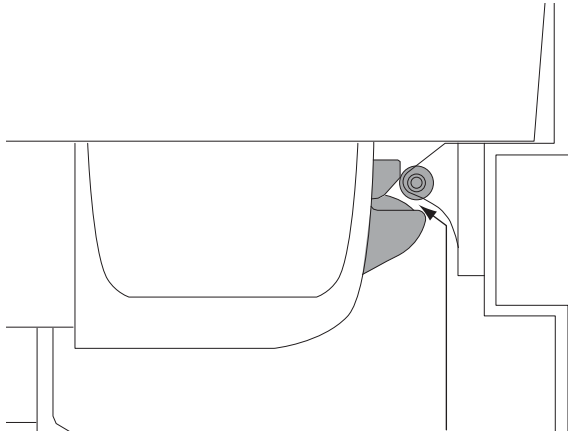

Gap
(no more than 3/16")

10

When properly adjusted, secure strike with additional screw(s).

909 Strike

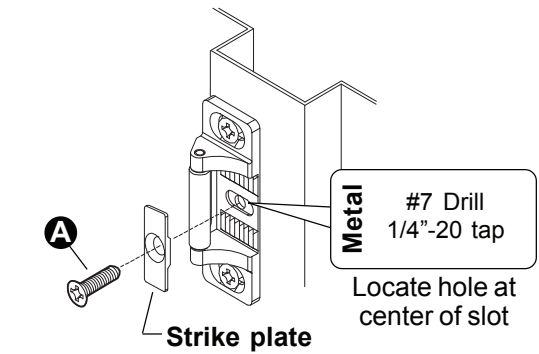

954 Strike

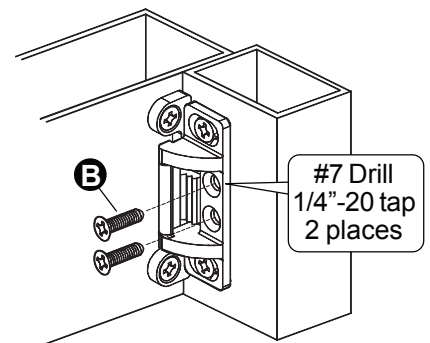

11

IMPORTANT!

Perform operational check.

- A. With door closed, push against door without touching device.
Device should **NOT** allow door to open.

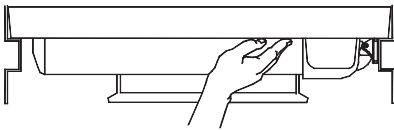

- B. With door closed, push device pushbar.
Device should allow door to open.

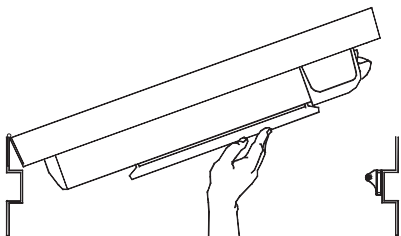

- C. If device does not function as described, adjust strike position and continue operational check until device functions as described above.

12

Note about the XP latch operation

The XP latch bolt operates differently from a standard latch bolt. When the pushbar is depressed, the latch bolt does not retract. This is normal because the XP latch bolt can swivel in both directions.

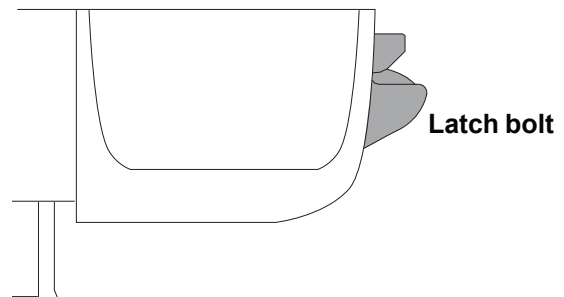

RETROFIT INSTALLATION

1 Remove existing exit device and old strike from door.

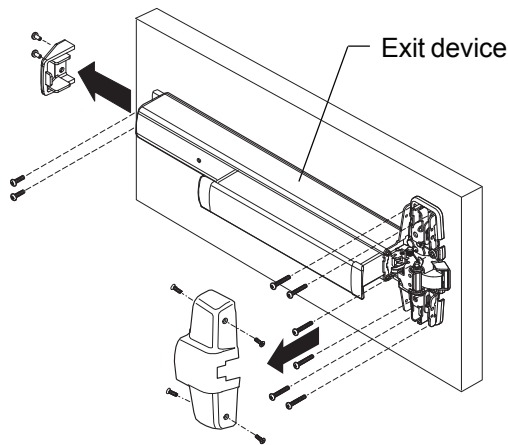

2 Install new 909 strike to replace 299/299F strike.

A. Re-drill and tap existing center strike hole for 1/4"-20.

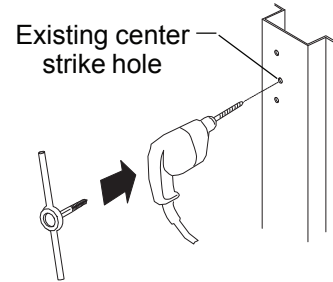

B. Attach strike to frame with new center screw and locking plate and position strike against door.

C. Mark and prepare 2 outer holes for 1/4"-20 and install screws.

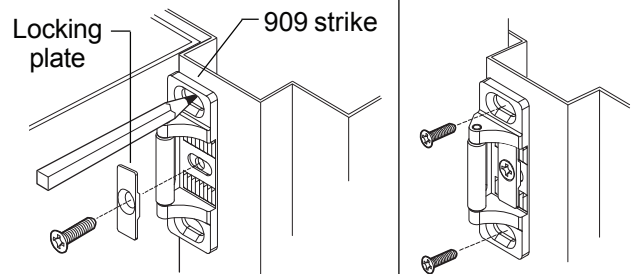

CAUTION

Old 299/299F or 499F strike cannot be used with XP98/99 device. Strike must be removed and replaced with new strike.

Old strike	Replace with
299/299F	909
499F	954*

*See page 11 for 954 installation

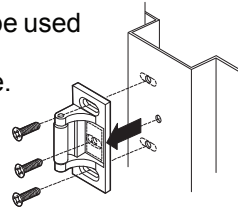

3 Mark and prepare 2 new support holes in door.

- Align plastic template with existing holes as shown.
- Mark 2 new holes as shown.
- Prepare 2 new holes per chart below:

	Metal	Wood
	#25 Drill #10-24 tap	1/8" Drill pilot 1" deep

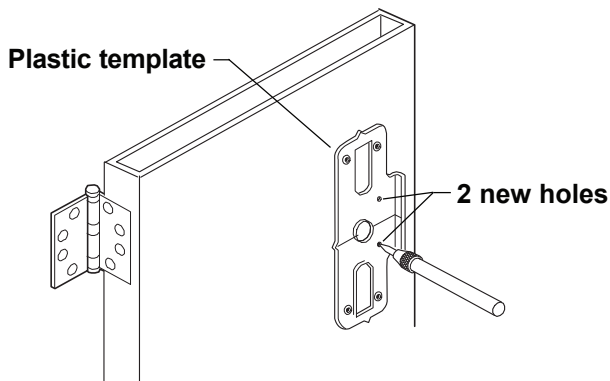

NOTE:

If plastic template will not align correctly with the 4 outer holes, bolt new XP exit device on door temporarily with the 4 screws and use it as a template to mark the 2 holes shown above.

4 Match master cam function for new XP device to that of removed exit device.

- Inspect underside of old center case for master cam.
- If NL drive screw (shown below) has been removed, it must be removed from new XP center case as well.

If NL drive screw is present in old center case, leave NL drive screw in new XP center case.

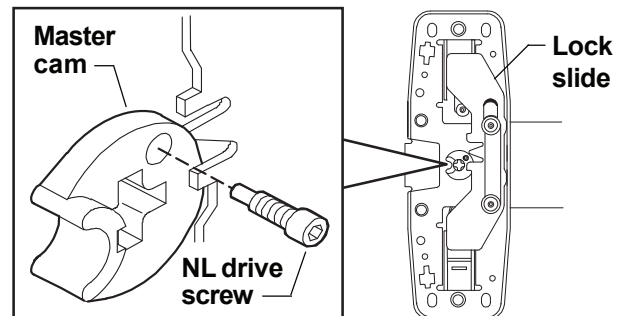

Go to page 5-6 and continue device installation steps 7-10.

HEX DOGGING INFORMATION

To undog exit device:

Note: Panic devices are shipped dogged (pushbar down).

1. To undog device, place hex key in hole as shown and turn counterclockwise releasing pushbar.

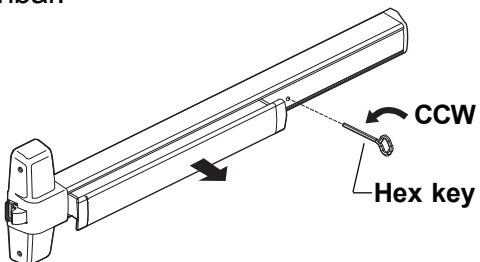

To dog exit device:

Note: Dogging is recommended during times of high traffic through door.

1. Depress pushbar.
2. Place hex key in hole as shown and turn clockwise. Pushbar stays in down position.

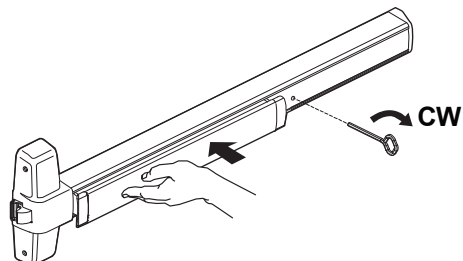

CD (CYLINDER DOGGING)

(DO NOT USE ON FIRE RATED DEVICE)

1. Remove mortise cylinder cam and reinstall in reverse (Figure 1).
2. Insert key and rotate cam to install the cylinder to the cover plate (Figure 2).
3. Remove key to slide cover plate in position in the mechanism case.

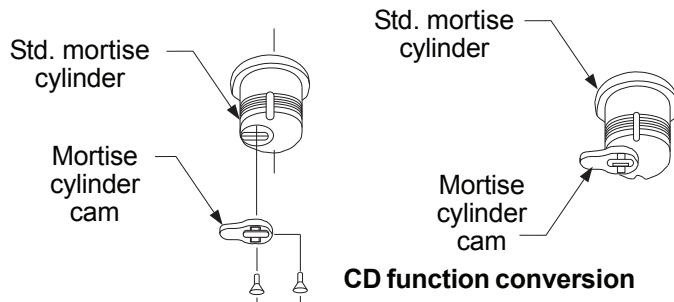

Figure 1

Dogging procedure

1. Depress pushbar
2. Turn cylinder key clockwise approx. 1/8 turn for standard dogging

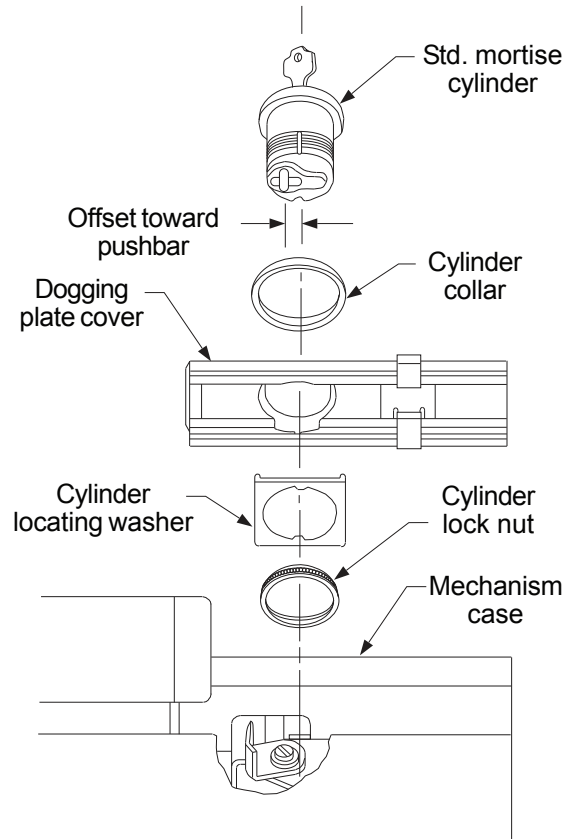
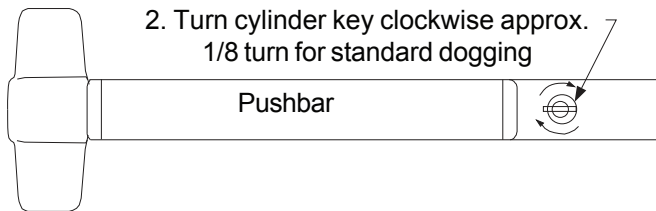
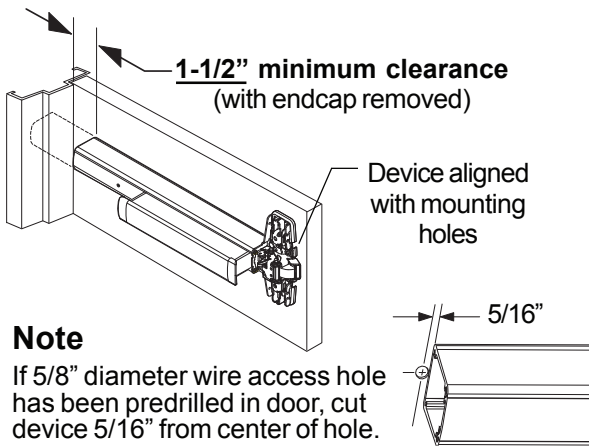

Figure 2

CUT DEVICE

1 Measure amount to cut off device.



2 Tape and mark area being cut.

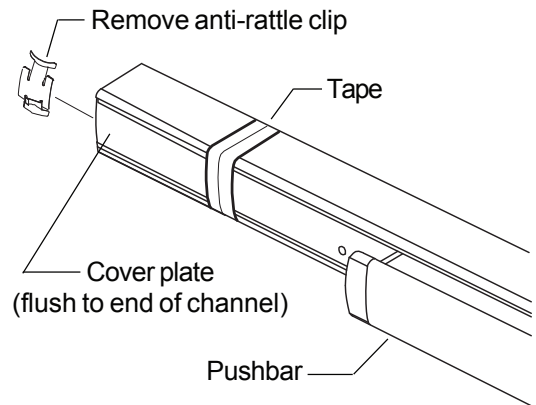

3 Cut device square.

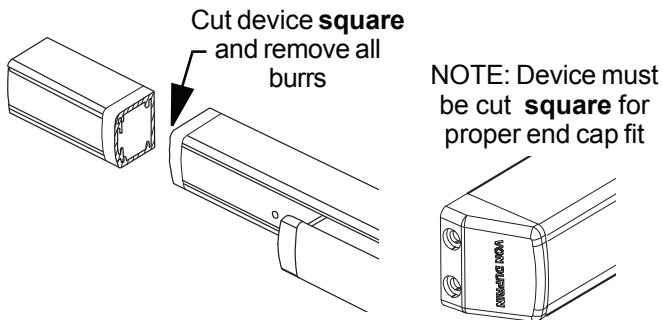

4 Slide anti-rattle clip into device.

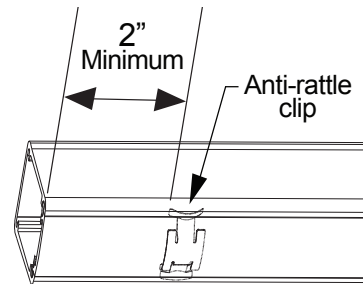

954 STRIKE INSTALLATION

1 Install strike hook along exit device ☉.

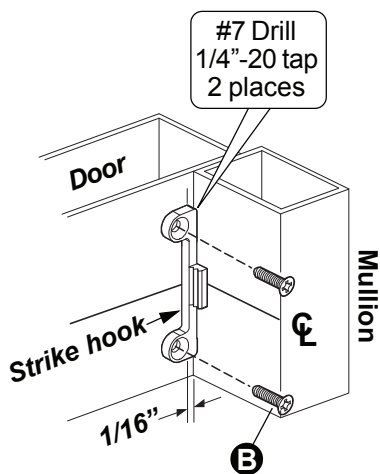

2 Mark 2 slotted holes for strike.

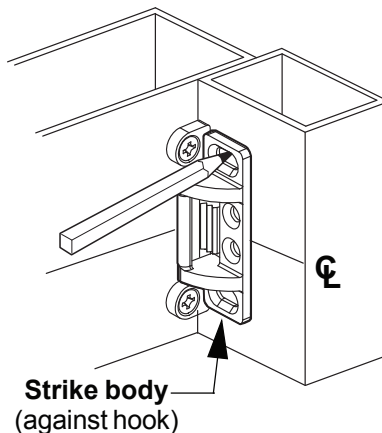

3 Prepare 2 holes and install 2 screws as shown.

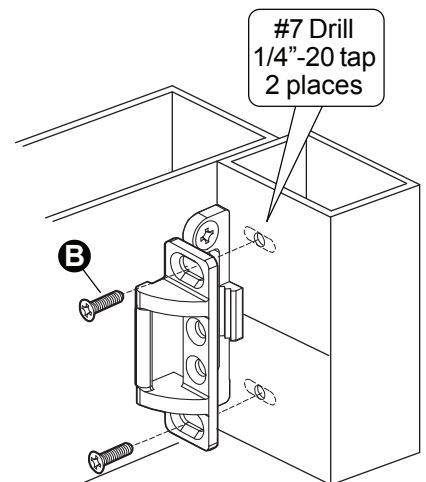

Customer Service

1-877-671-7011 www.allegion.com/us



© Allegion 2016
Printed in U.S.A.
911000-00 Rev. 05/16-e