



911373-00

98/99

VON DUPRIN®

Rim Exit Device

Installation Instructions

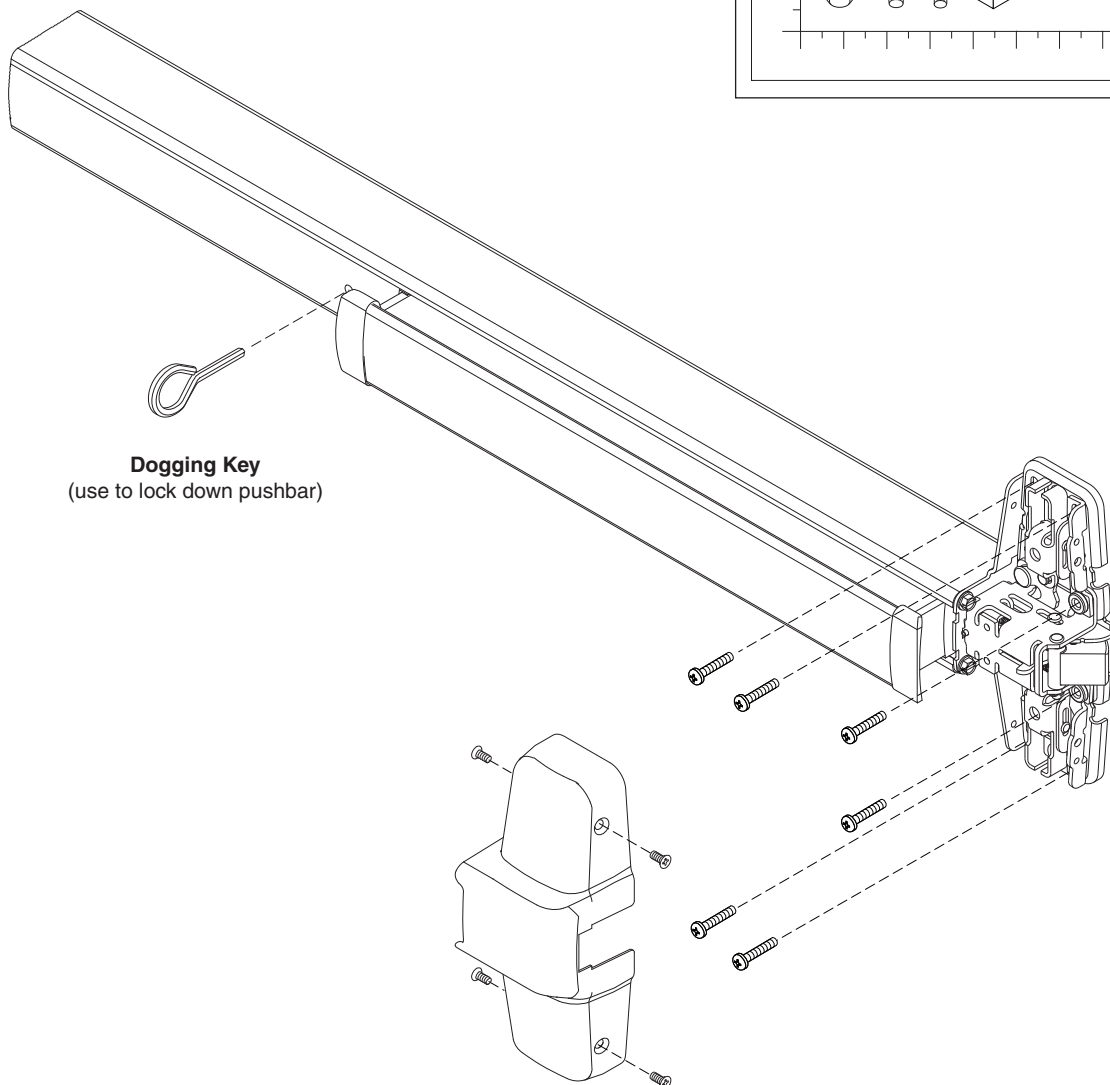
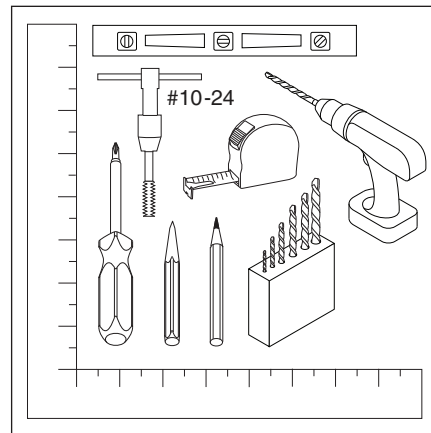
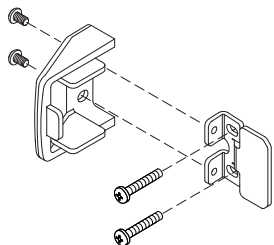



**Dogging Key**  
(use to lock down pushbar)



**Customer Service**  
1-877-671-7011    [www.allegion.com/us](http://www.allegion.com/us)

© Allegion 2015  
Printed in U.S.A.  
911373-00 Rev. 11/15-g

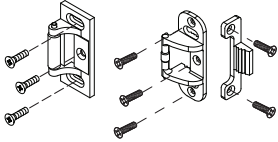
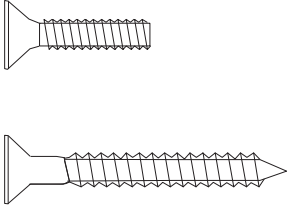
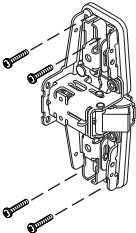
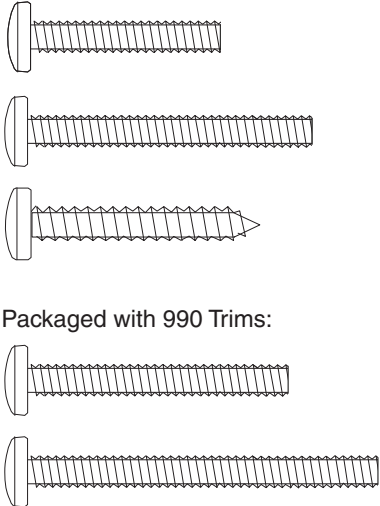
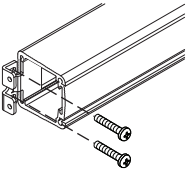
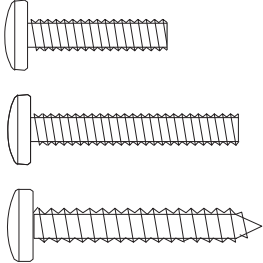
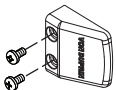
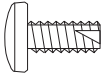
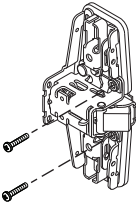
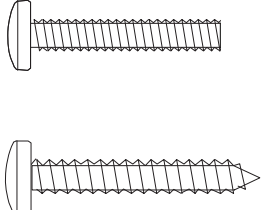
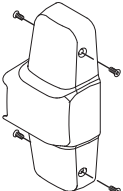
## SCREW CHART

Subassembly	Screw		Application
<p><b>A</b></p>  <p>299 Strike    499F Strike</p>		<p>#10-24 x 3/4" (19 mm)</p> <p>#10 x 1 1/2" (38 mm) Wood screw</p>	<p>Metal frame</p> <p>Wood frame</p>
<p><b>B</b></p> 	 <p>Packaged with 990 Trims:</p>	<p>#10-24 x 1" (25 mm)</p> <p>#10-24 x 1 1/2" (38 mm)</p> <p>#10 x 1 1/4" (32 mm) Wood screw</p> <p>#10-24 x 1 3/8" (35 mm)</p> <p>#10-24 x 1 7/8" (48 mm)</p>	<p>Surface mount or Sex bolts 1 3/4" (44 mm) door</p> <p>Sex bolts, 2 1/4" (57 mm) door</p> <p>Surface mount (wood)</p> <p>1 3/4" (44 mm) door, 990 Trim</p> <p>2 1/4" (57 mm) door, 990 Trim</p>
<p><b>C</b></p> 		<p>#10-24 x 3/4" (19 mm)</p> <p>#10-24 x 1 1/8" (29 mm)</p> <p>#10 x 1 1/4" (32 mm) Wood screw</p>	<p>Surface mount or Sex bolts 1 3/4" (44 mm) door</p> <p>Sex bolts, 2 1/4" (57 mm) door</p> <p>Surface mount (wood)</p>
<p><b>D</b></p> 		<p>#10-16 x 3/8" (10 mm) Thread cutting</p>	<p>End cap</p>
<p><b>E</b></p> 		<p>#10-24 x 1" (25 mm)</p> <p>#10 x 1 1/4" (32 mm) Wood screw</p>	<p>Surface mount (metal)</p> <p>Surface mount (wood)</p>
<p><b>F</b></p> 		<p>#8-18 x 3/8" (10 mm) Thread cutting</p>	<p>Center case cover</p>

# 1 Draw horizontal device and strike center lines (☉).

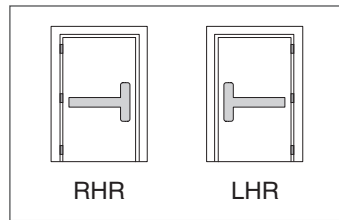
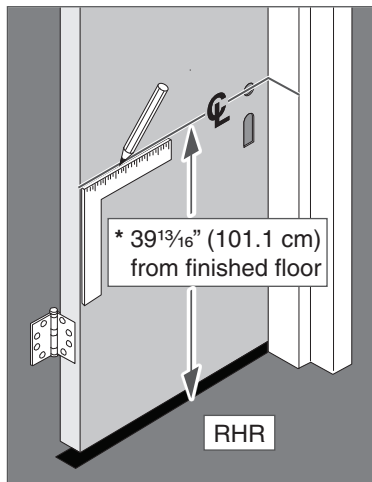

\* For double doors with a mullion and strike already installed, use existing strike center line.

# 2 Align strike on ☉ and mark the two slotted holes.

ⓘ For 499F strike installation, see page 6.

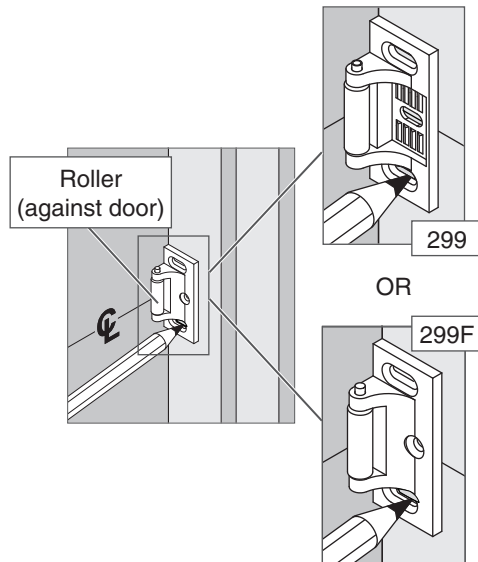

ⓘ For more information on the strikes shown below, go to <http://w3securitytechnologies.com> and look for the Support area for Von Duprin installation instructions.

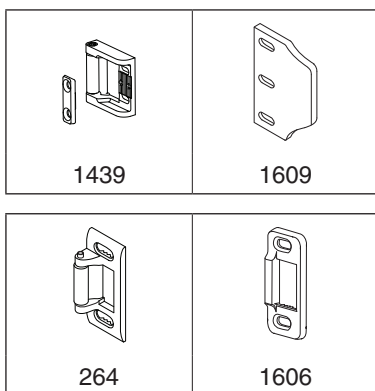

# 3 Prepare 2 holes and install 2 screws.

ⓘ See "Screw Chart" on previous page for screw types and sizes

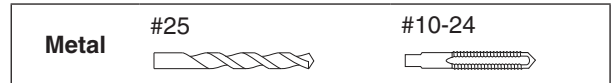
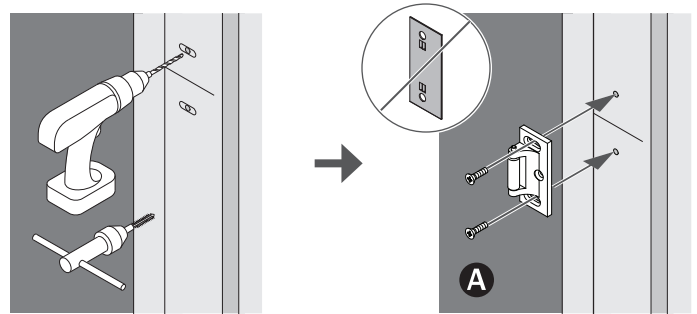

OR

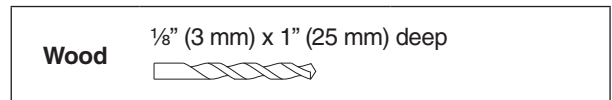

# 4 Position template against strike and on ☉ and mark door.

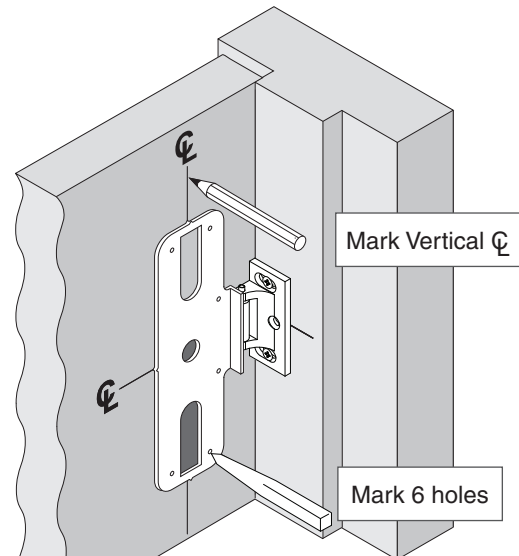

# 5 If necessary, prepare cutouts for cylinder and trim.

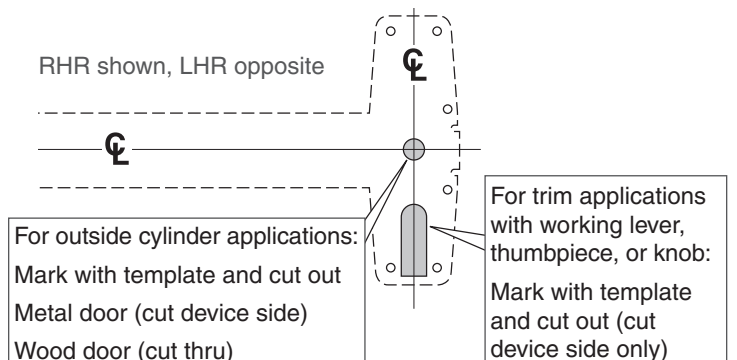

## 6 Prepare 4 center case mounting holes.

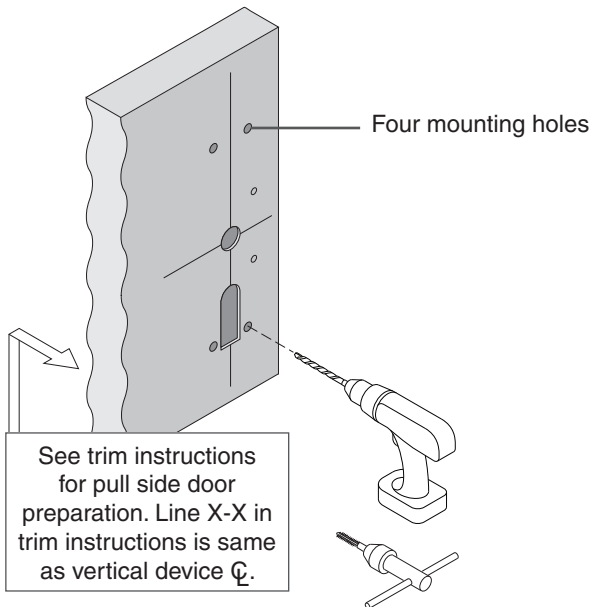

	SURFACE MOUNT	OR	SEX BOLTS or 990 TRIMS
WOOD	#25		1/4" (6 mm) Device Side
METAL	#10-24		13/32" (10 mm) Trim Side
	1/8" (3 mm) x 1" (25 mm) Deep		13/32" (10 mm) Drill Thru

## 7 Prepare 2 center case support holes.

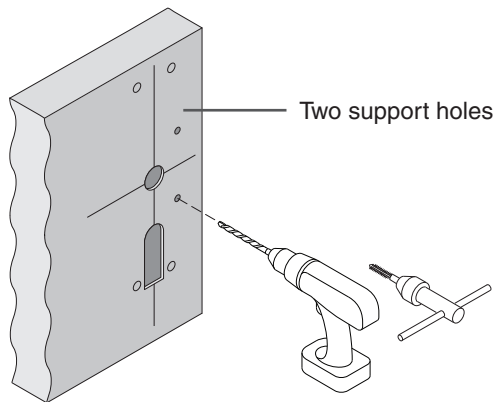

	METAL	OR	WOOD
	98/99 and 98/99-F		98/99
	#25		1/8" (3 mm) x 1" (25 mm) Deep
	#10-24		98/99-F
			#825 Sex bolts (2) required
			1/16" (2 mm) 3/8" (10 mm)
			Exterior
			5/16" (16 mm)

## 8 If necessary, remove NL drive screw

### NL drive screw

Factory installed on back of center case

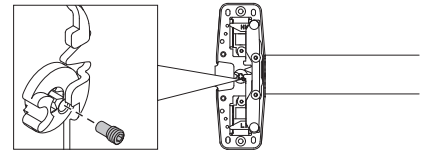

With the NL drive screw removed, key locks and unlocks lever, knob, or thumb piece. For the trims listed below, **REMOVE** NL drive screw.

996L	696TP	990TP
996K	697TP	

With the NL drive screw installed, key retracts latch bolt. **DO NOT** remove NL drive screw for the following applications:

NL, EO, DT trims and 98/99-2 double cylinder devices (i.e. TP-2, L-2, and K-2).

*996L-BE	*E996L	*696TP-BE	*990TP-BE
*996K-BE	*E996L-BE	*697TP-BE	

\* If the trim being installed is "BE" (i.e. 996L-BE), the trim lock tumbler on the back of the device must be in the **UP** position before device is installed. This allows the trim to be unlocked at all times.

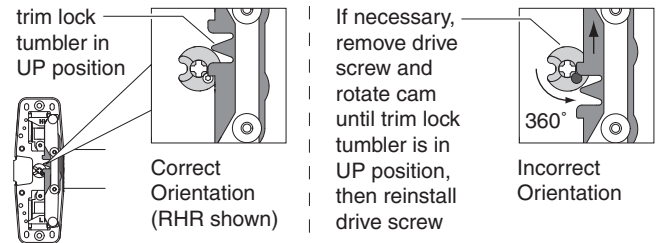

## 9 If using a cylinder with a tailpiece, prepare device and cylinder.

### 9a Install tailpiece guide.

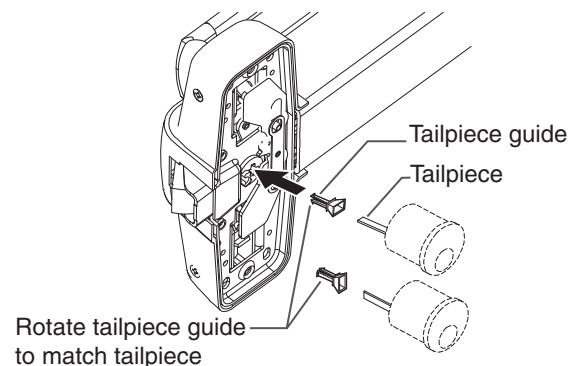

### 9b Cut tailpiece as needed.

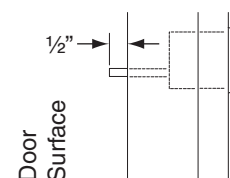

**10** If necessary, cut device.

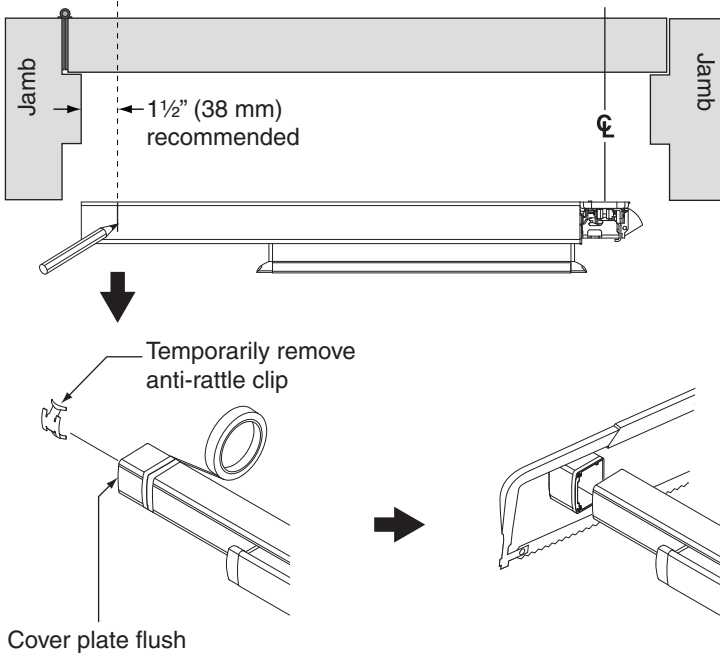

**12** Mark and prepare two (2) holes.

**i** Prepare holes after lock side of device is mounted and hinge side is leveled.

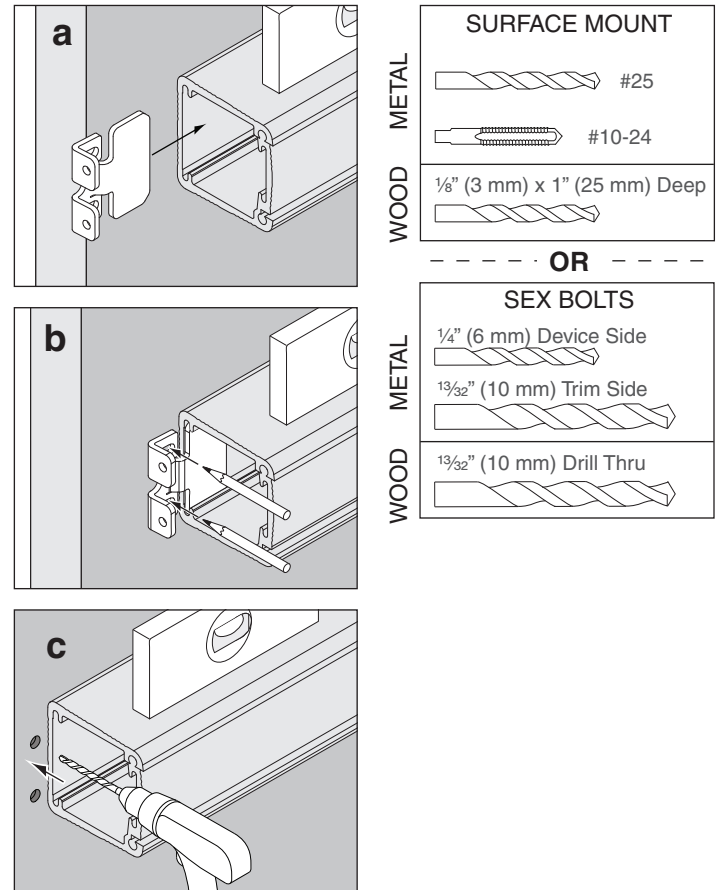

**11** Attach center case to door.

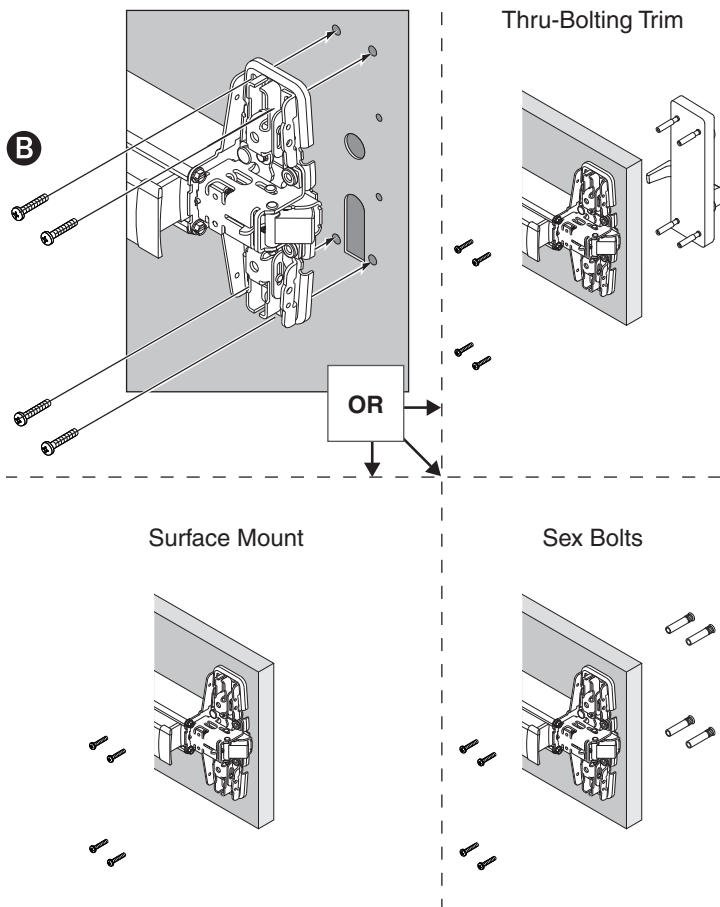

**13** Install end cap bracket and end cap.

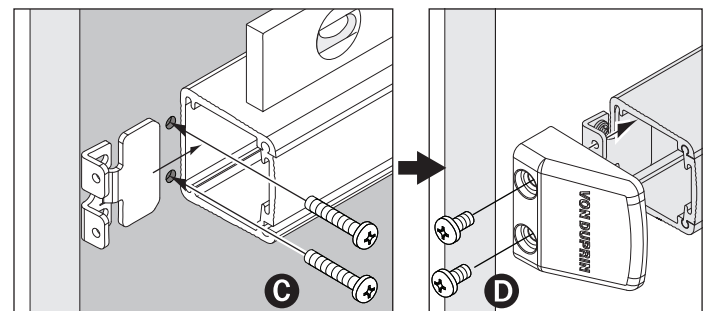

**14** Install required support screws and center case cover.

Remove protective film from pushbar

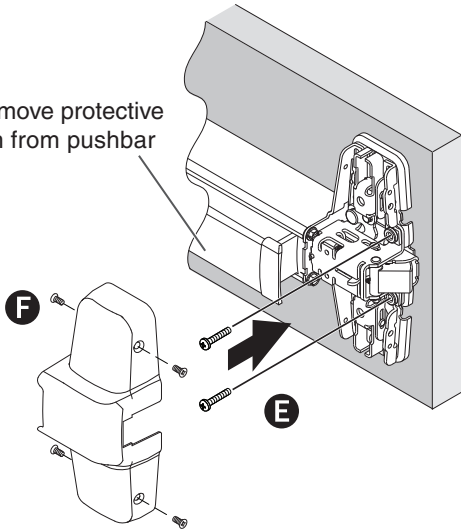

**15** Adjust strike as needed.

299/299F Strike

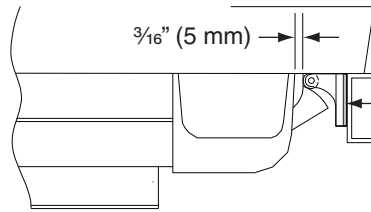

Shim as needed

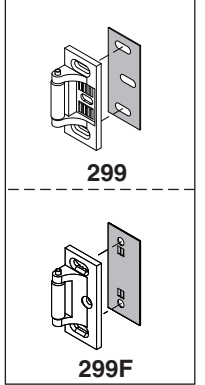

**16** Install strike support screw.

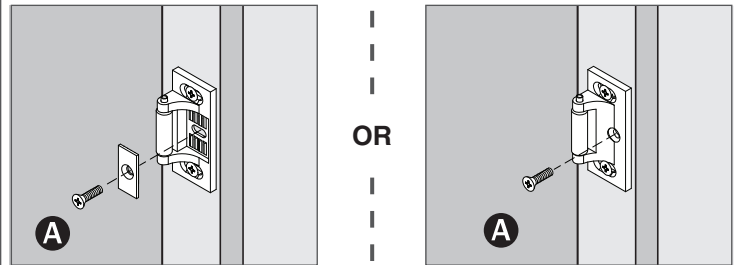

METAL	WOOD
#25	1/8" (3 mm) x 1" (25 mm) Deep
#10-24	

**499F STRIKE INSTALLATION**

1. Prepare and install screws through two strike slots.

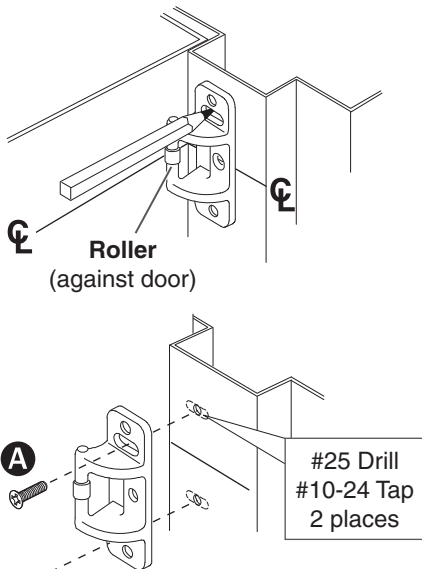

**i** If using a mullion, holes may be predrilled

2. Install strike hook and additional strike screws.

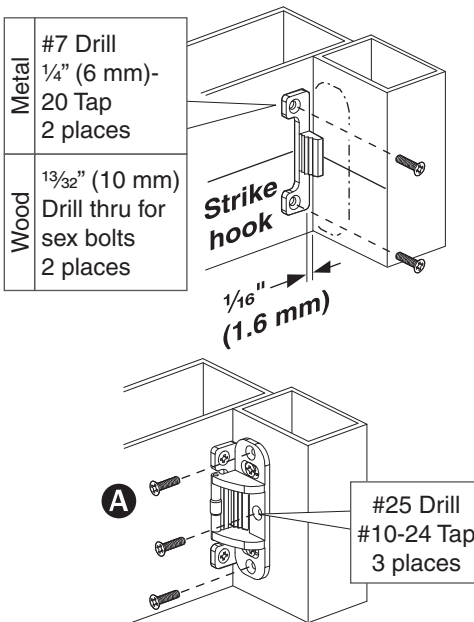

3. Template aligns as shown.

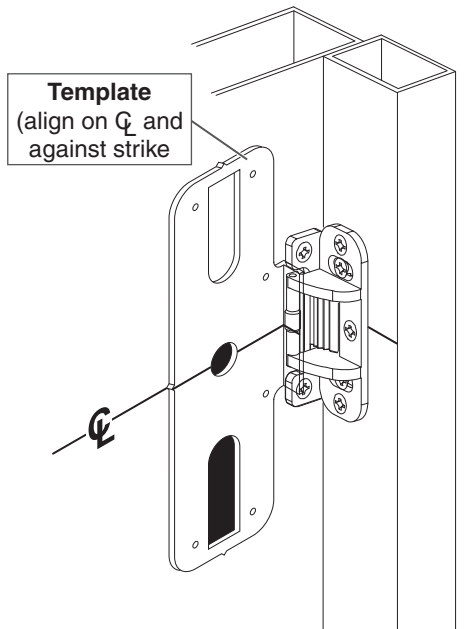

## OPTIONAL EQUIPMENT

### CD (Cylinder Dogging) Option

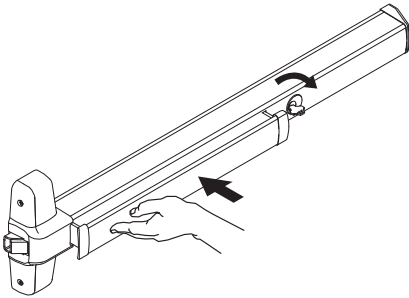
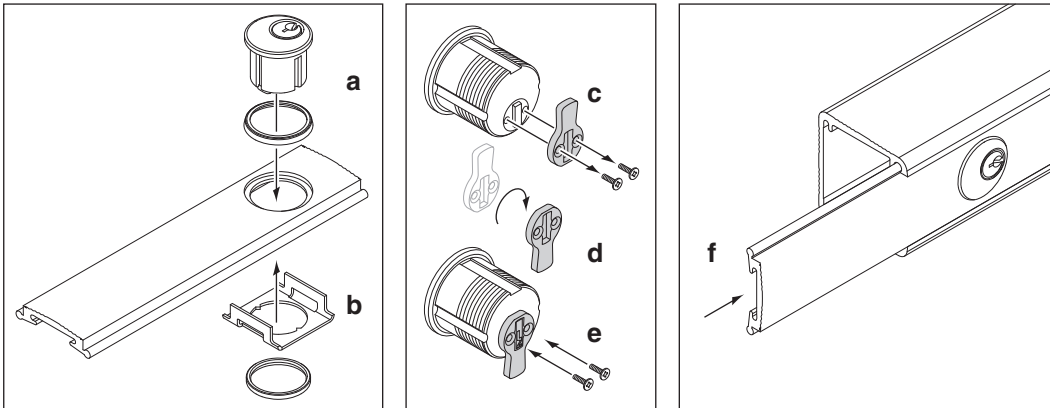

Dog

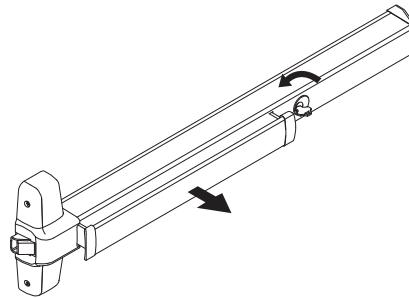

Undog

# OPTIONAL EQUIPMENT

## 99-2 (Double Cylinder) Option

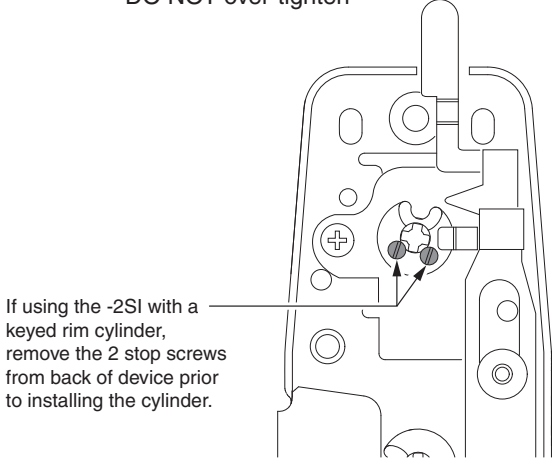
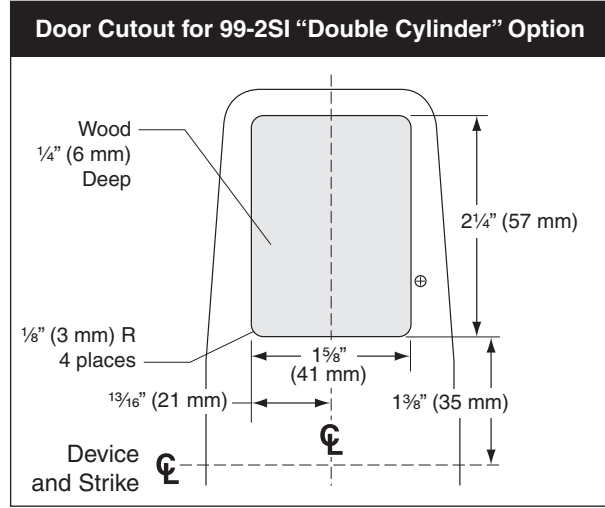
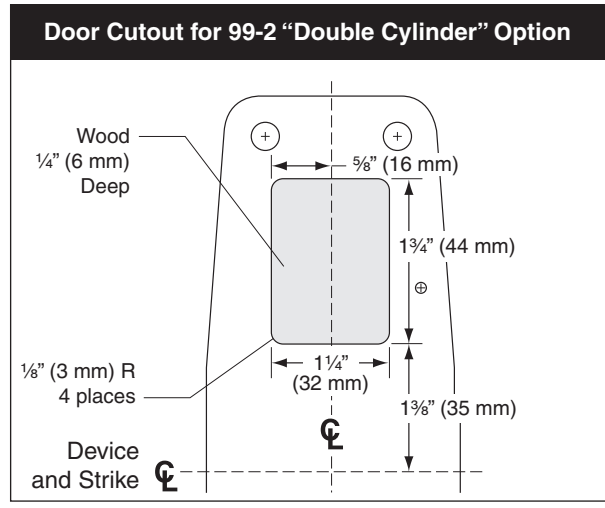
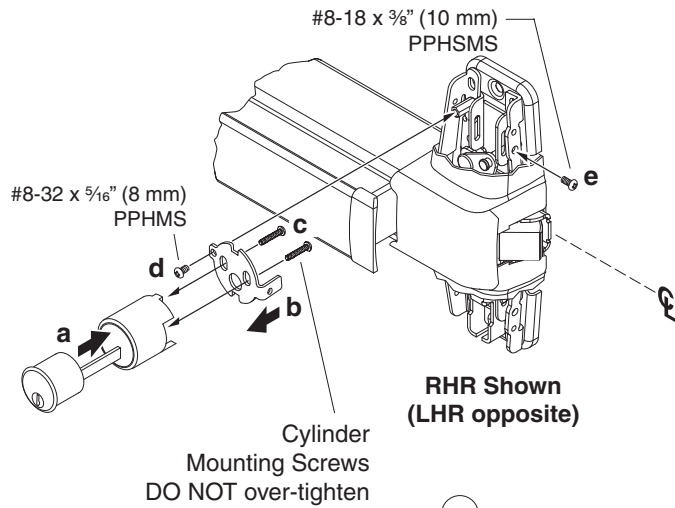

If using the -2SI with a keyed rim cylinder, remove the 2 stop screws from back of device prior to installing the cylinder.

For 98/99-2SI models with Classroom Security Indicator, apply supplied labels above and below cylinder to match door handing, and label on indicator.

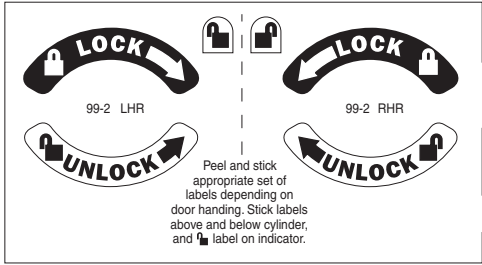

**Manually affix the label:**

Ensure surface is clean of dirt, dust, or oils. Clean with alcohol if necessary.

Peel the label from the paper backing and apply to the surface. Minimize handling when applying and use pressure to burnish label to surface. The adhesive will require up to 8 hours to achieve the proper bond.

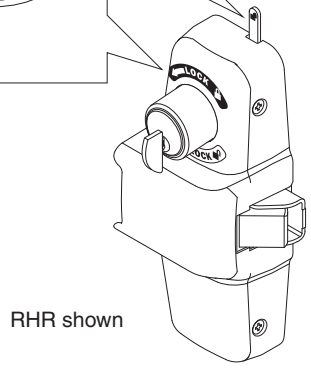





941255-00

EL/HD-EL

VON DUPRIN®

Conversion Kit

Installation Instructions

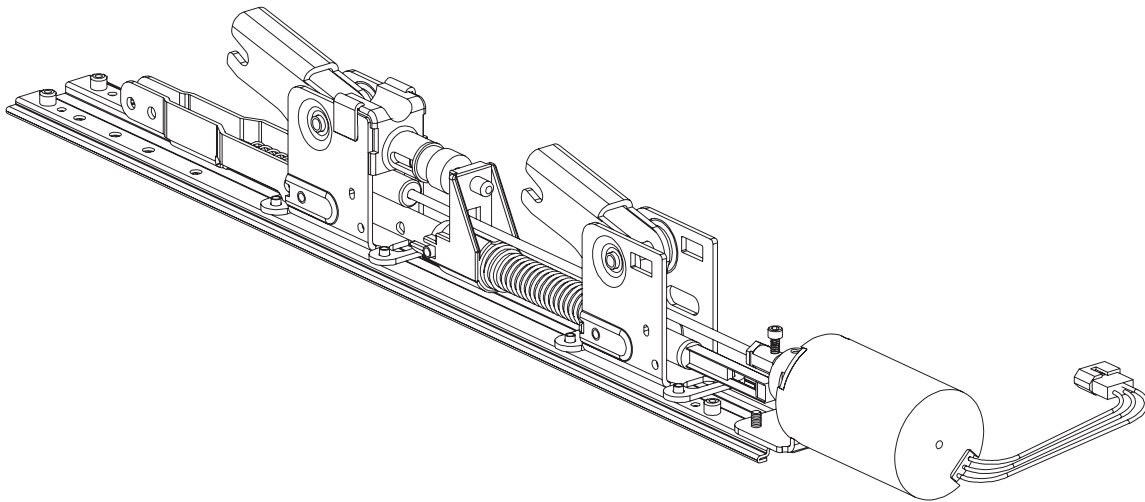

Read All Warnings  
Before Starting Installation!

Index

- General Information ..... 2
- Specifications ..... 2
- Parts List ..... 2
- Warnings ..... 2
- Tools Needed ..... 2
- Installation ..... 3
- EL Wiring and Adjustment ..... 12

Customer Service

1-877-671-7011    www.allegion.com/us



© Allegion 2014  
Printed in U.S.A.  
941255-00 Rev. 01/14-c

## GENERAL INFORMATION

This kit converts 33/35, 33A/35A, and 98/99 series devices to electric latch (EL) retraction devices. Before beginning installation, review “Specifications,” “Parts List,” “Warnings,” and “Tools Needed.”

## SPECIFICATIONS

### Solenoid:

Continuous duty: 24 VDC  
Current inrush: 16 A  
Current holding: 0.3 A

## PARTS LIST

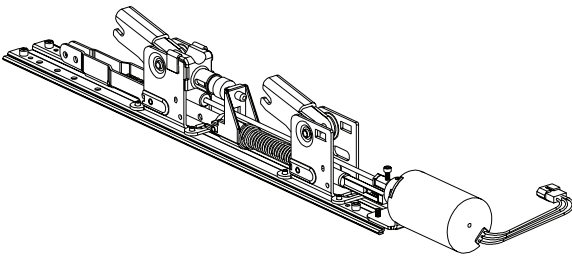

Baseplate with solenoid

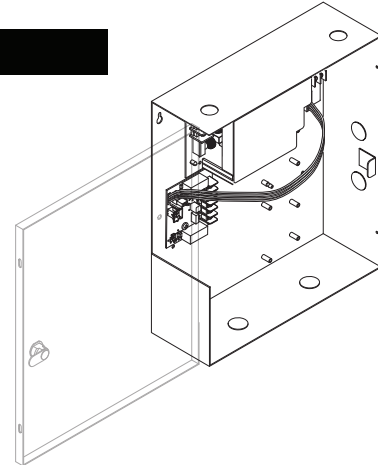

PS914 power supply with 900-2RS logic board  
\*not in kit



Pin and retaining clip

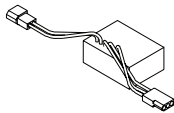

Circuit breaker

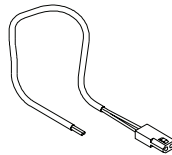

Cable

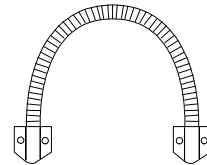

DL-12 door loop  
\*not in kit

\* This part is required for installation but not included in this kit. Contact factory to order.

## WARNINGS

1. This kit cannot be used to convert 33/35 Rim devices. Consult factory.
2. Install according to instructions or device will not function and panic or fire label will be void.
3. The solenoid wiring must be attached to the fire alarm system if installed on fire exit hardware.
4. PS914 power supply with 900-2RS logic board must be used for EL device to operate properly.
5. Field wiring between the power supply and the door must be 12 AWG.

## TOOLS NEEDED



5/8" dia. drill bit



Flat blade screwdriver

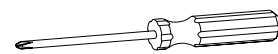

Phillips screwdriver

**1** Remove device from door if installed (find correct device on page 3 or 4).

**⚠ WARNING**

Device and trim must be held securely while removing mounting screws to prevent device and trim from dropping to the floor.

### 98/99 Rim/Mortise Device

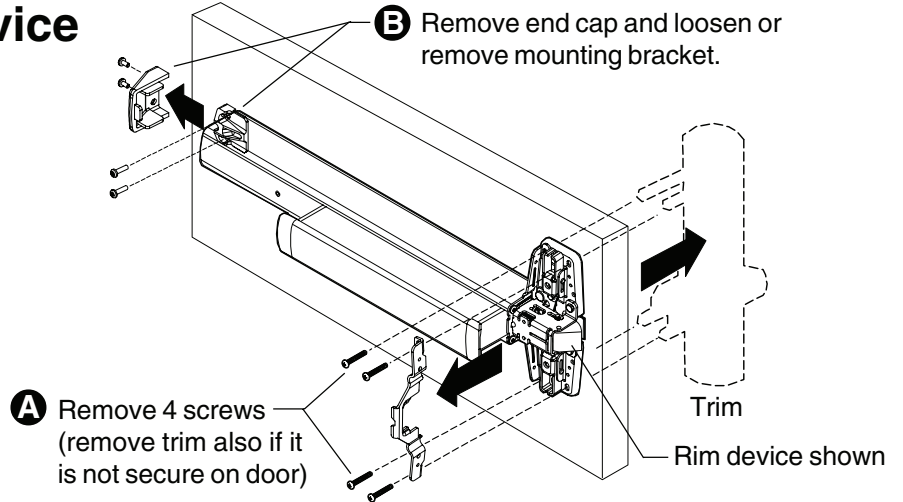

### 9827/9927 Device

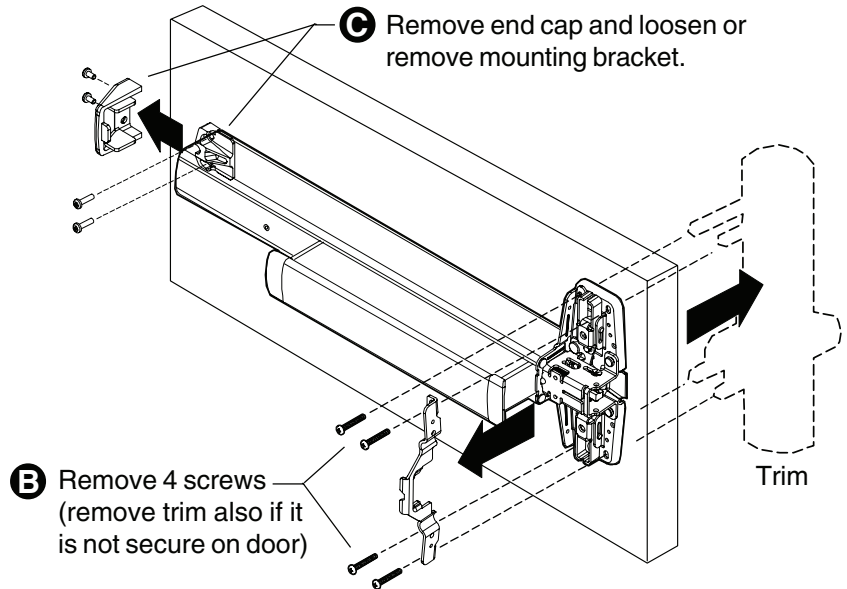
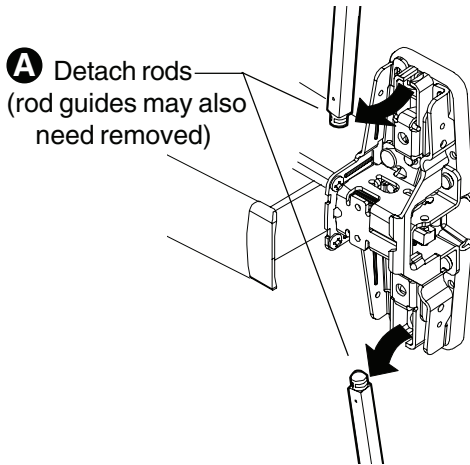

### 9847/9947 Device

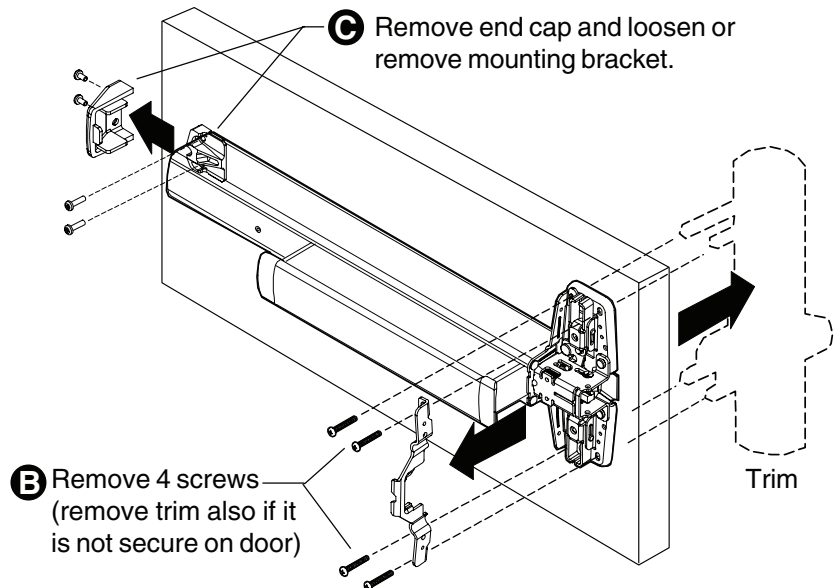
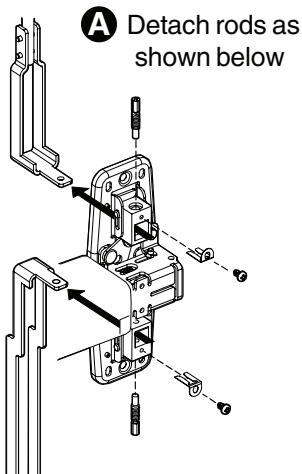

### 33A/35A Rim Device

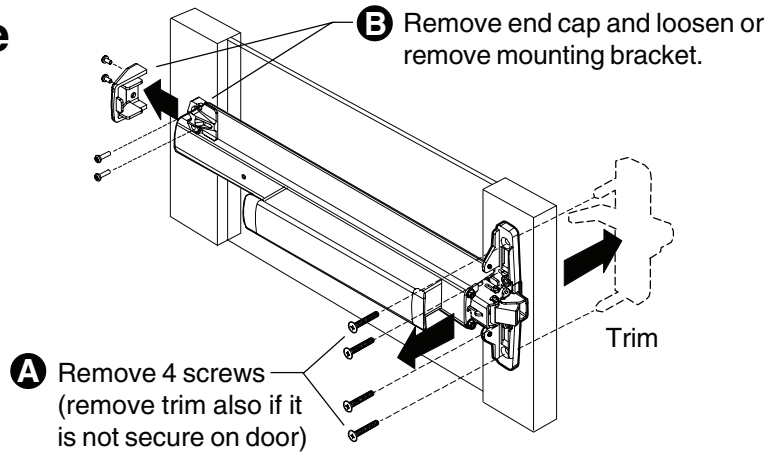

### 3327/3527 & 3327A/3527A Device

**A** Detach rods (rod guides may also need removed)

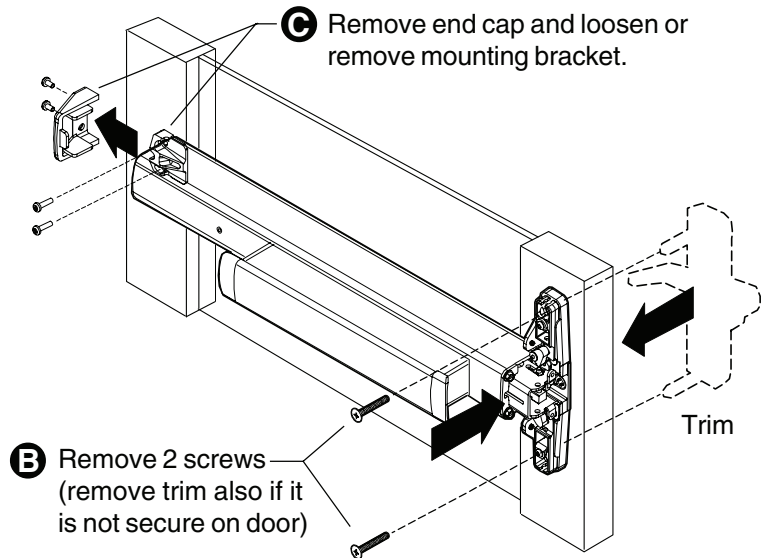
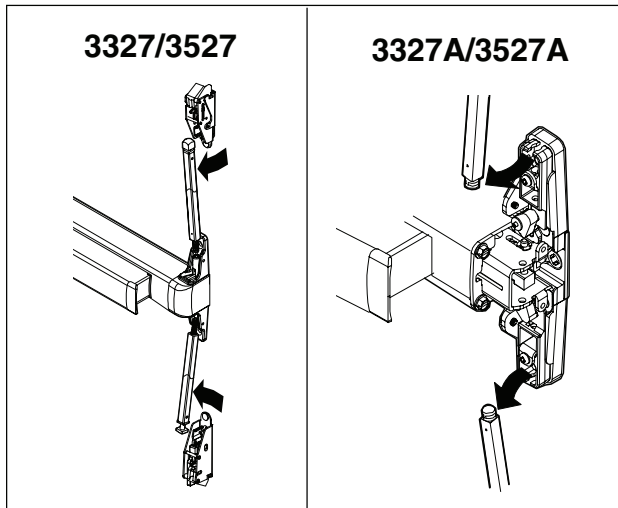

### 3347/3547 & 3347A/3547A Device

**A** Detach rods as shown below

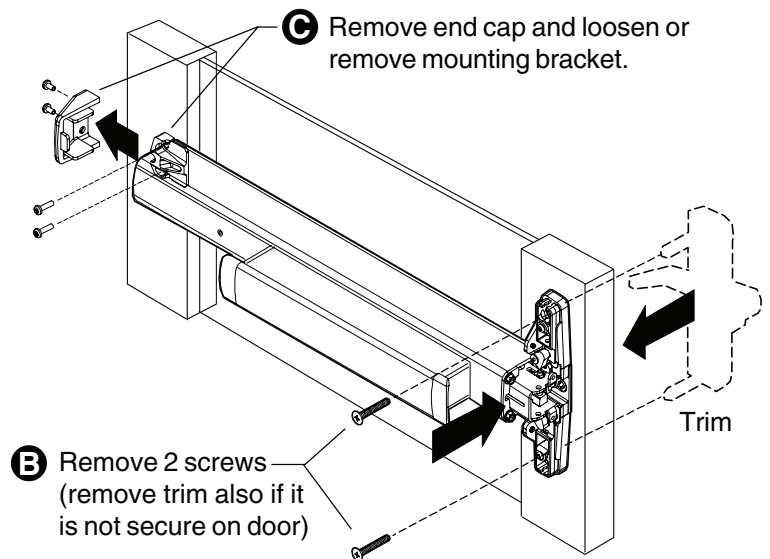
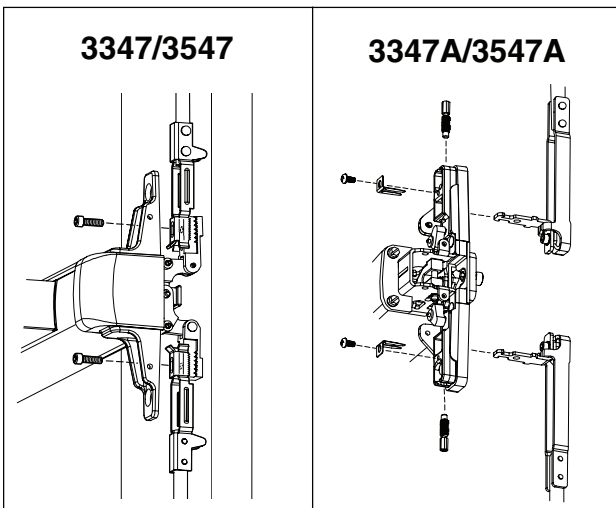

### 33/35 Device

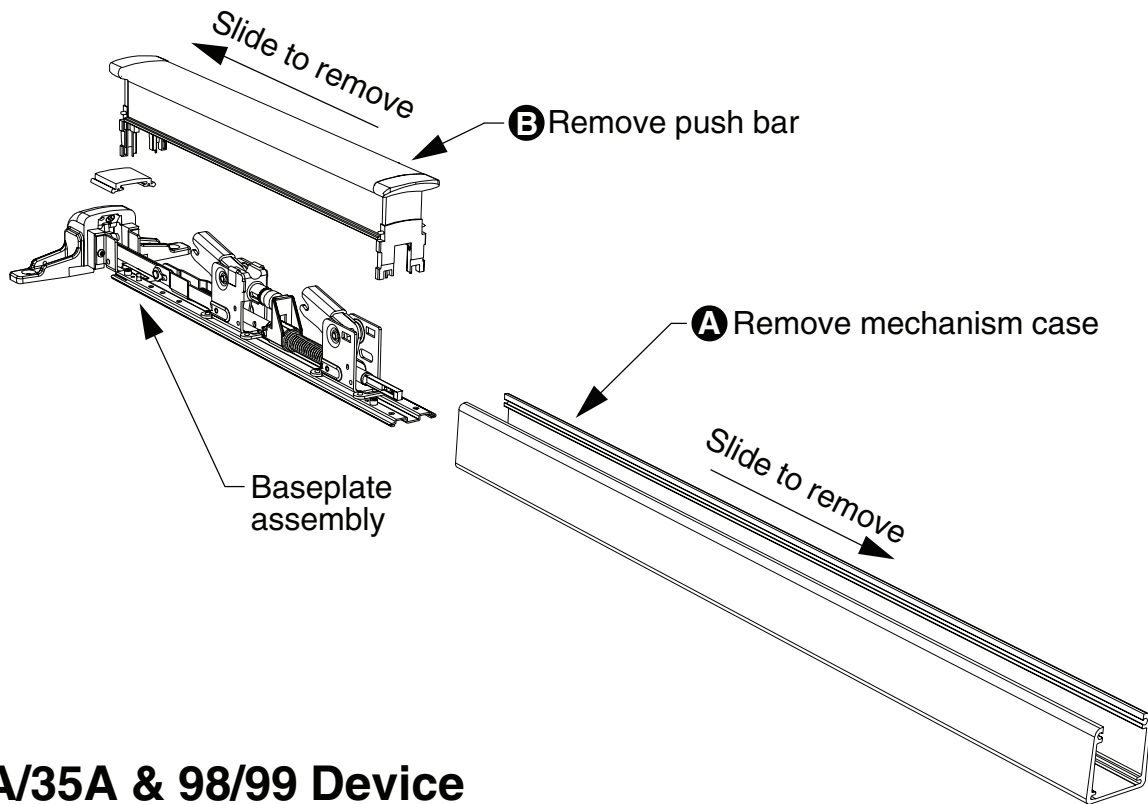

### 33A/35A & 98/99 Device

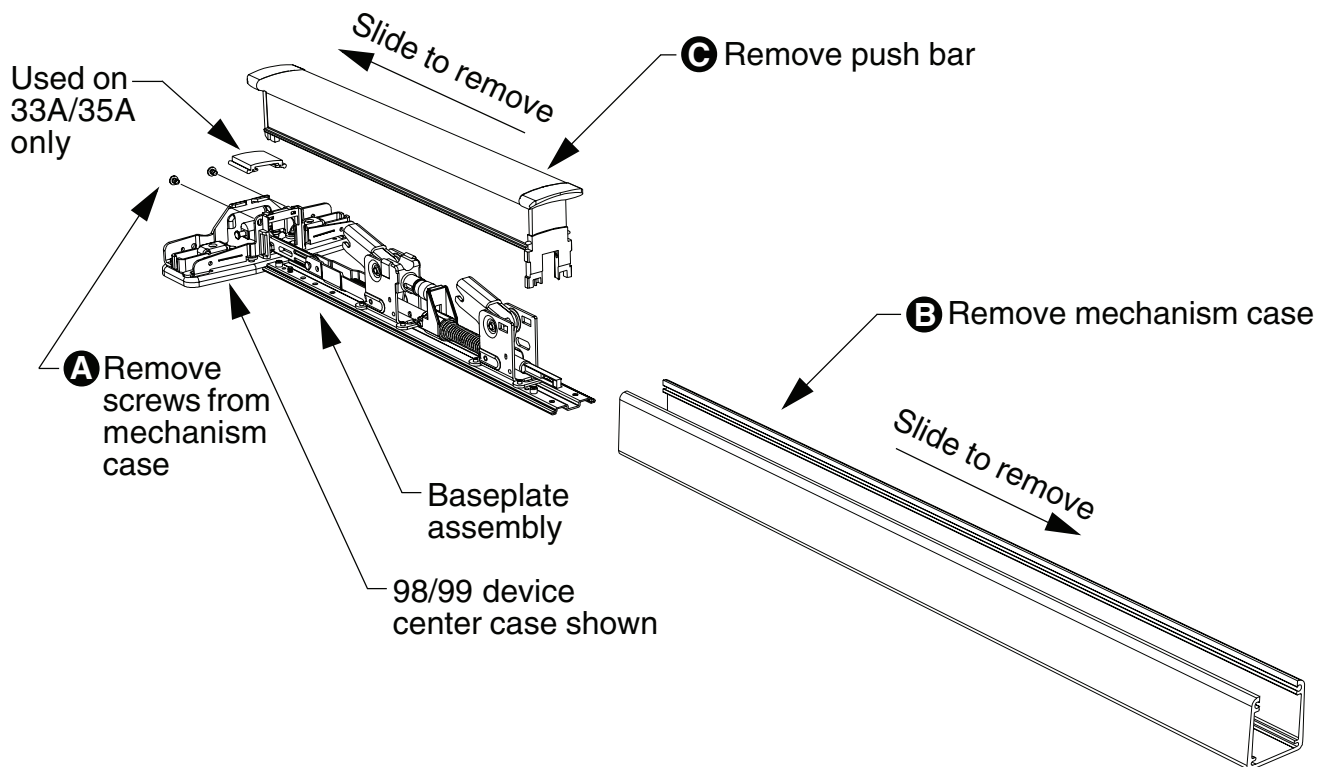

**3** Remove main link retaining ring and pin.

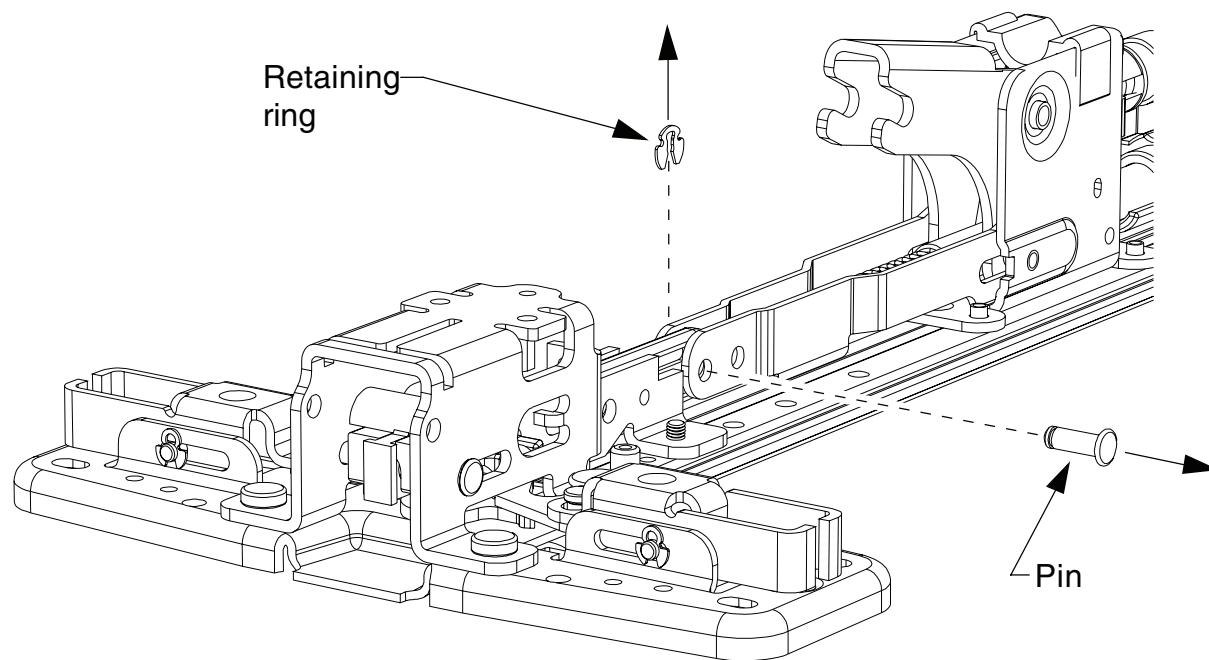

**4** Remove screws connecting center case to baseplate.

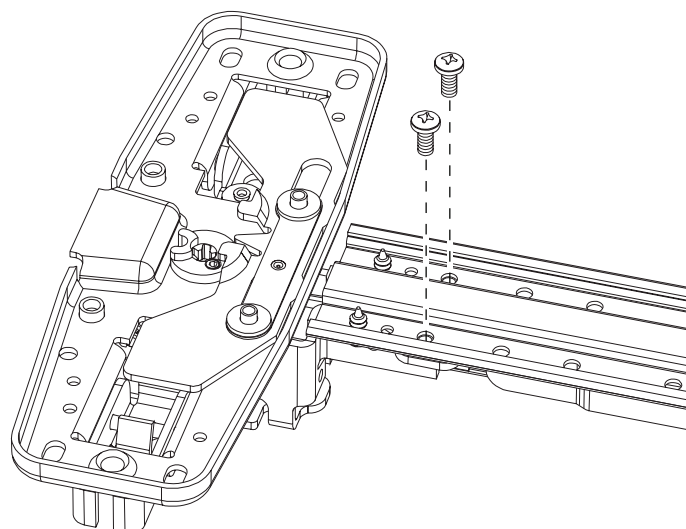

**5** Install center case to new EL baseplate.

**Warning:** Make sure retaining ring is secure in the pin groove. If retaining ring is not secure it could result in an exit device that will not allow exit. This is a serious safety issue.

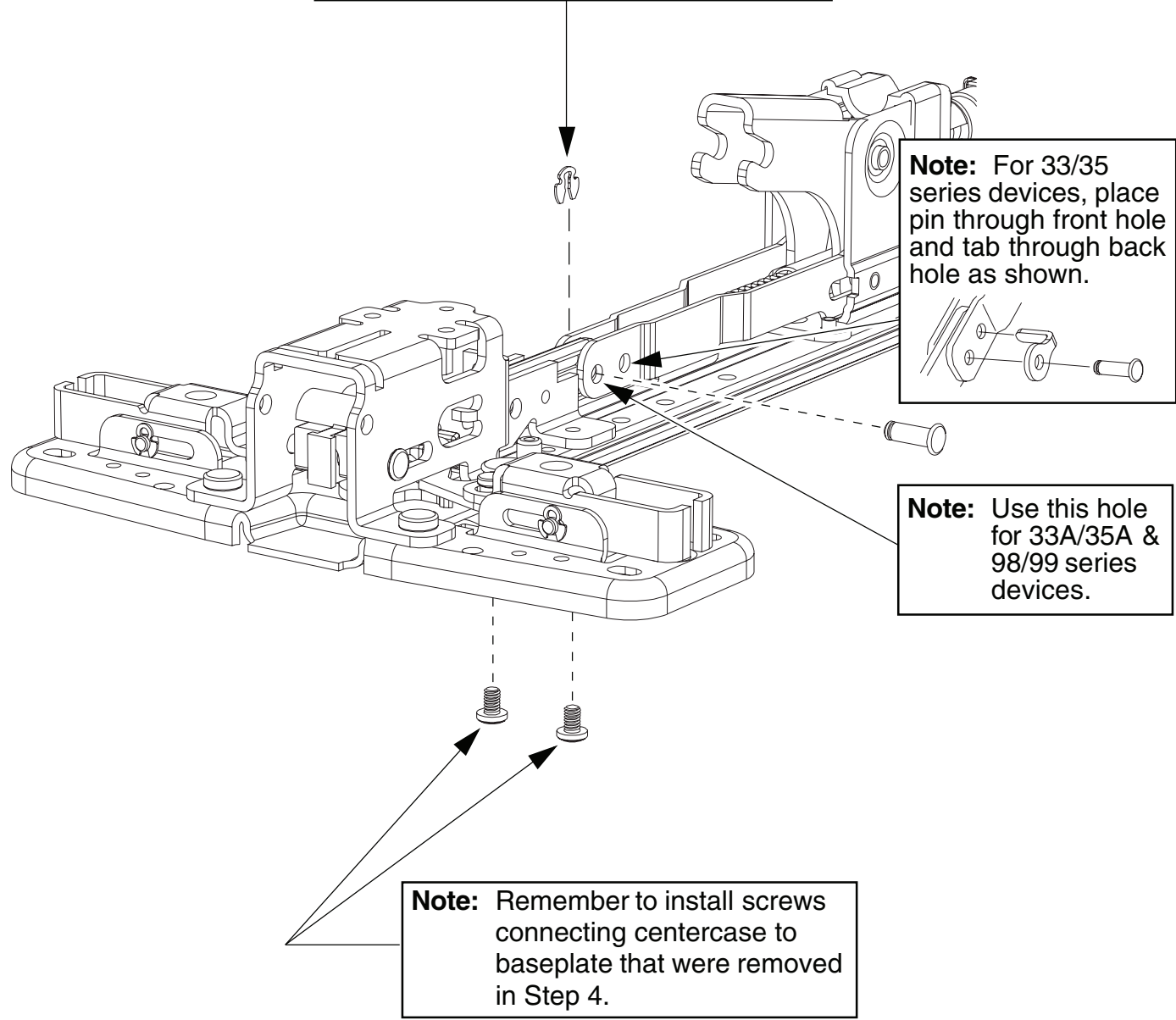

## 6 Reassemble device.

### 33/35 Device

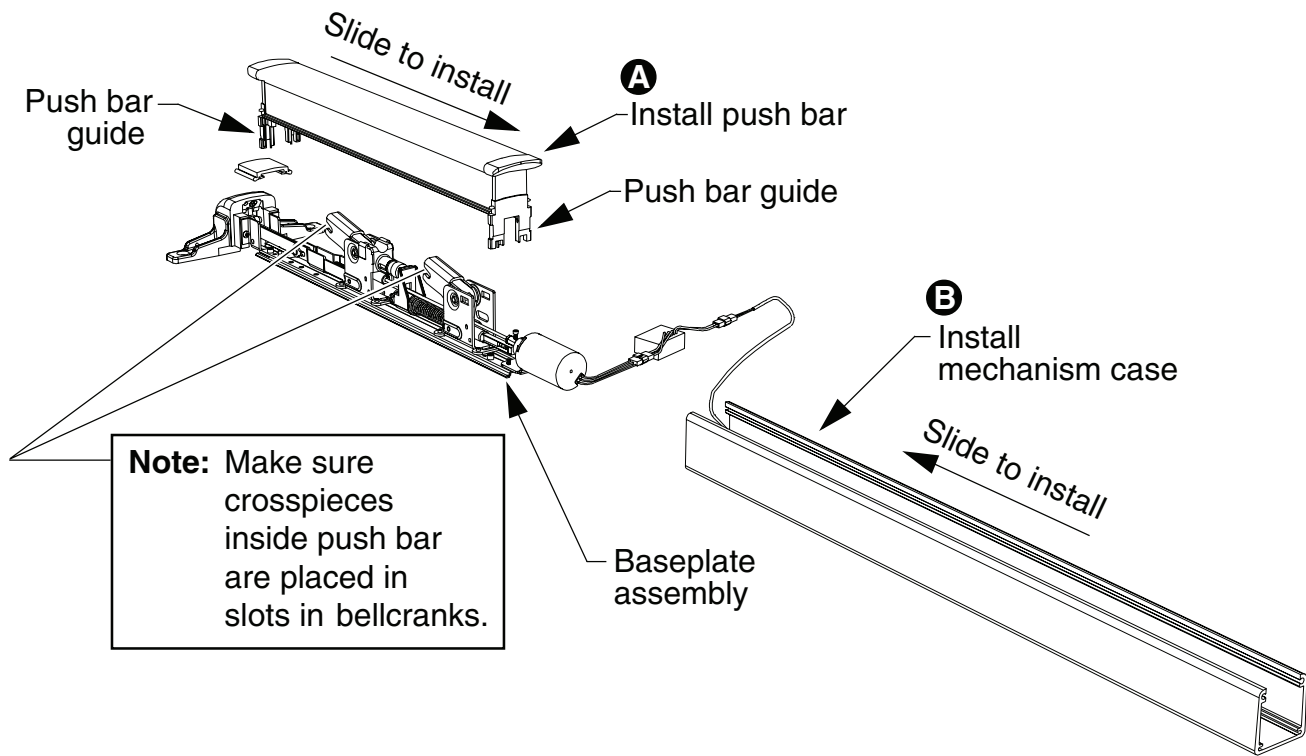

### 33A/35A & 98/99 Device

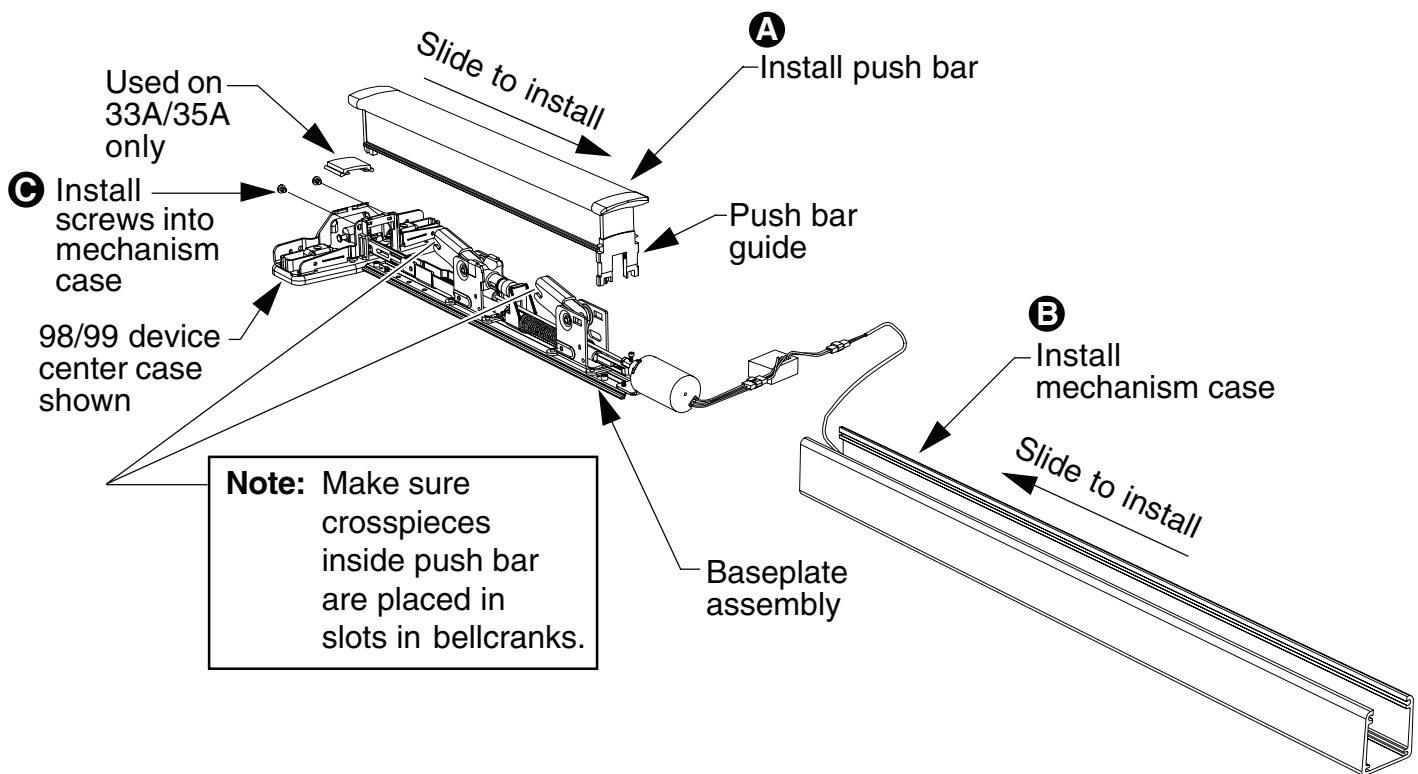



**7** Drill solenoid cable hole and install device to door.

- A. Drill 5/8" diameter hole in door centered between end cap bracket mounting holes.
- B. Deburr hole.
- C. Reattach device and trim to door.

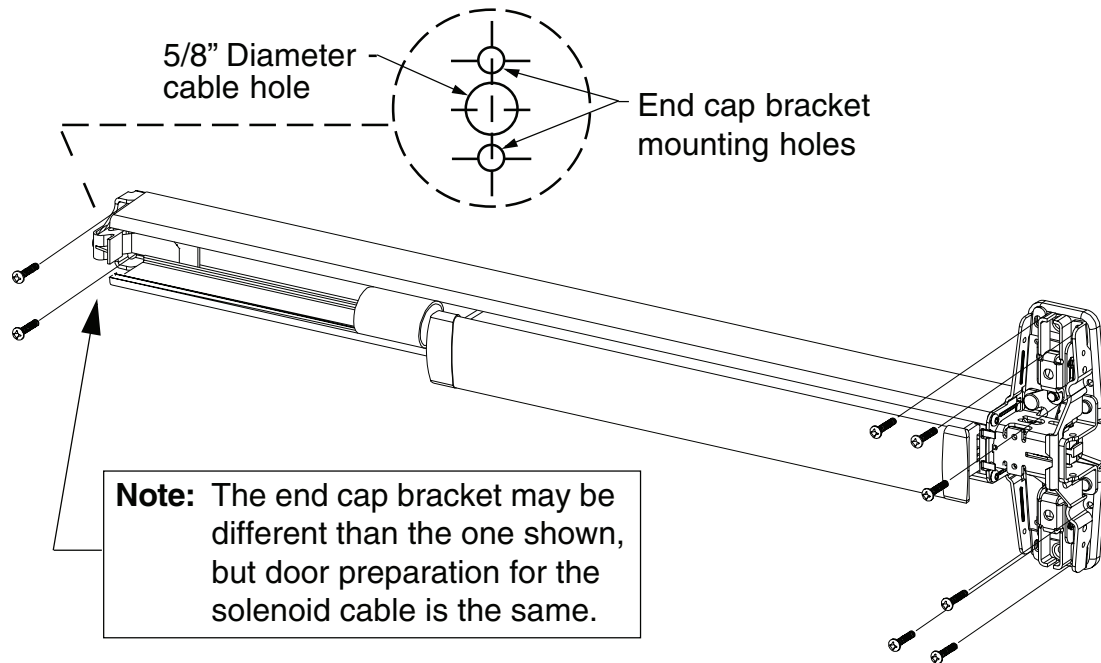

**8** Route cable through hole in door.

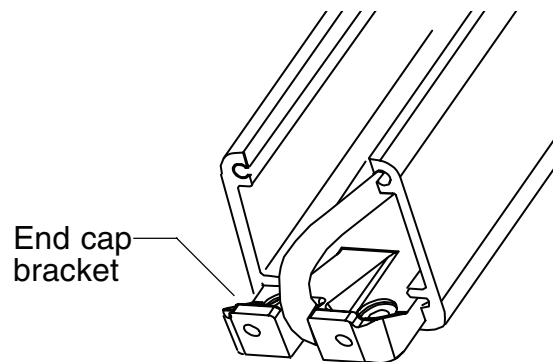

## 9 Install cover plate and end cap.

- A. If cover plate has a dogging key hole, rotate cover plate so hole is near end cap for standard EL device and near pushbar for HD-EL device.
- B. Install anti-rattle spring.
- C. Install cover plate.
- D. Install end cap.

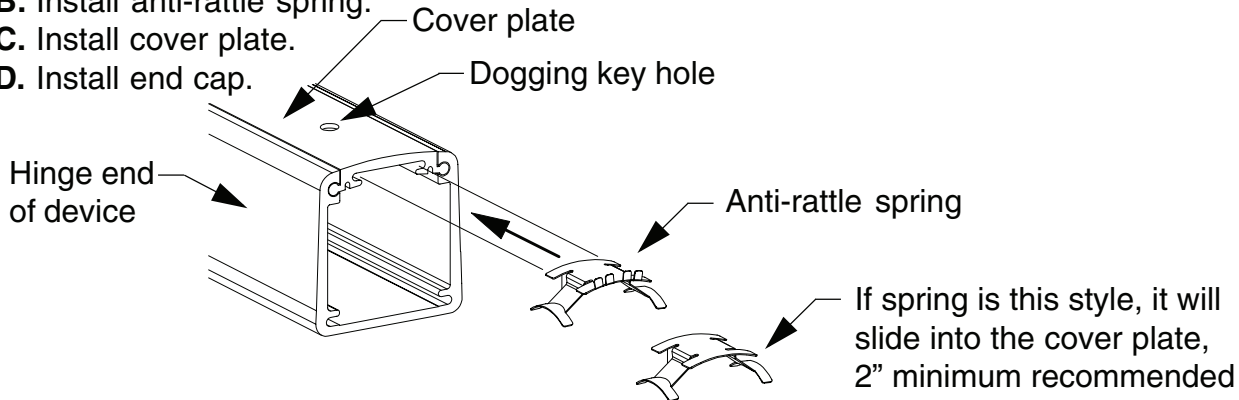

## 10 For vertical devices, reattach rods.

Reattach rods in reverse of when they were detached on pages 3 and 4.

## 11 Adjust rods as needed on vertical devices (find correct device on page 10 or 11).

### 9827/9927 Device or 3327A/3527A Device

Adjust top and bottom rod (screw rod into or out of latch) until adjusted as shown.

**Note:** On bottom latch, make sure latch bolt clears floor when door is swung open.

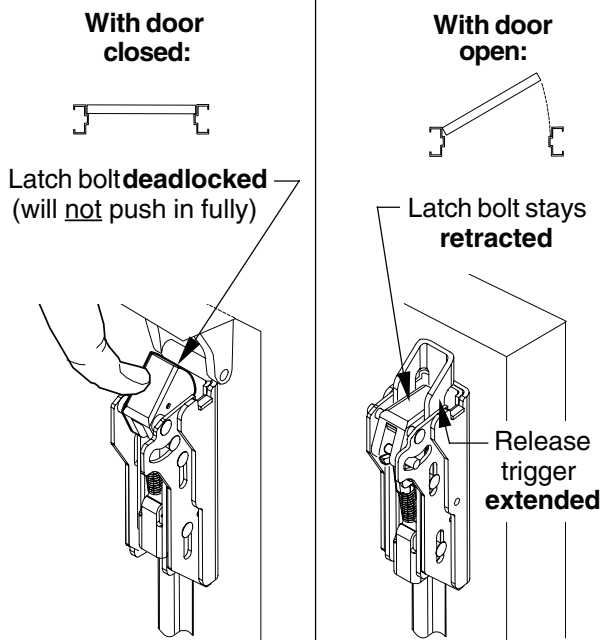

### 3327/3527 Device

Adjust top and bottom rod (screw rod into or out of center case rod connector) until adjusted as shown.

**Note:** On bottom latch, make sure latch bolt clears floor when door is swung open.

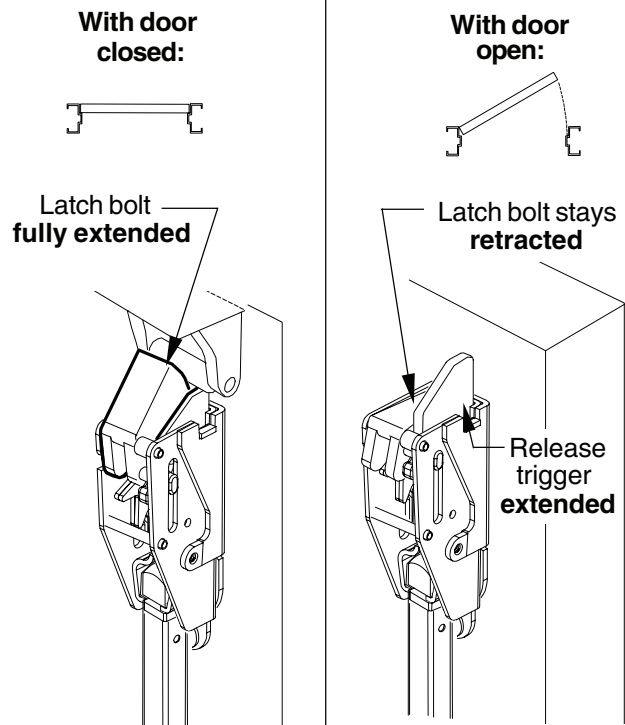

## 9847/9947 Device or 3347A/3547A Device

- A. Open door and release top latch bolt as shown (Figure 11-1).

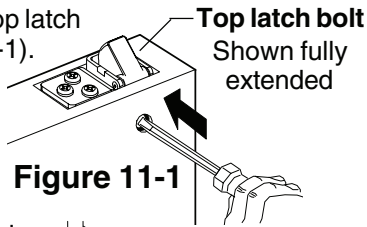

- B. Loosen bottom locking screw (Figure 11-2).

- C. Disconnect bottom vertical rod by removing bottom adjusting screw.

- D. Loosen top locking screw.

- E. Rotate top adjusting screw clockwise until top latch bolt is fully extended (Figure 11-1).

- F. Check top latch bolt for deadlocking (latch bolt should not push in fully).

- G. Turn top locking screw in. Do not over-tighten

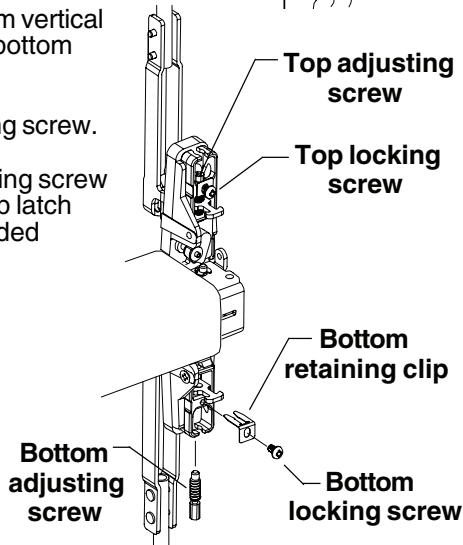

Figure 11-2

- H. Depress pushbar and release. (flush with latch case)

- I. Make sure top latch bolt stays retracted as shown.

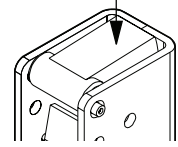

Figure 11-3

- J. Install bottom adjusting screw, retaining clip, and locking screw (Figure 11-2).

- K. With top latch bolt still retracted, adjust bottom rod so latch bolt clears floor and bottom strike.

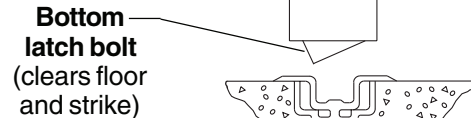

Figure 11-4

- L. Turn bottom locking screw in. Do not over-tighten.

- M. Close door and push up on bottom latch bolt to verify it is deadlocked (will not push in fully).

- N. Check device operation by opening and closing door several times from the outside.

**Redo adjustment procedure if :**

- Top latch bolt is not held retracted
- Bottom latch bolt does not clear floor and bottom strike

## 3347/3547 Device

- A. Loosen top and bottom adjusting screws.

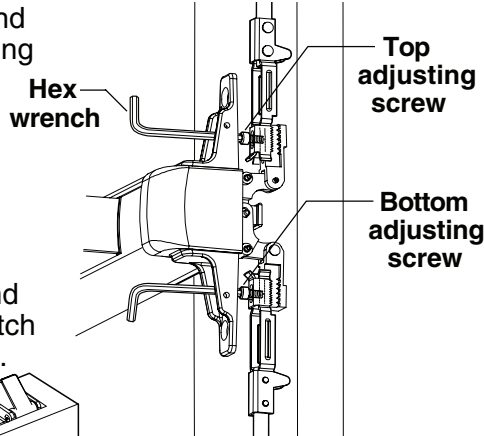

- B. Open door and release top latch bolt as shown.

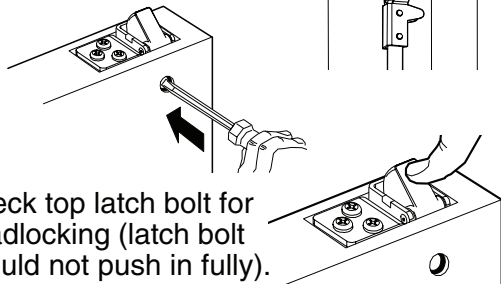

- C. Check top latch bolt for deadlocking (latch bolt should not push in fully).

- D. With top latch bolt still fully extended and pushbar in full up position (not depressed), tighten top adjusting screw.

- E. Depress pushbar and release.

Latch bolt retracted (flush with latch case)

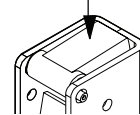

- F. Make sure top latch bolt stays retracted as shown.

- G. With top latch bolt still retracted, push bottom latch bolt up until it clears floor and bottom strike and hold it there.

Bottom latch bolt (clears floor and strike)

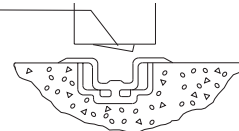

- H. Tighten bottom adjusting screw.

- I. Close door and push up on bottom latch bolt to verify it is deadlocked (will not push in fully).

- J. Check device operation by opening and closing door several times from the outside.

**Redo adjustment procedure if :**

- Top latch bolt is not held retracted
- Bottom latch bolt does not clear floor and bottom strike

## 12 Complete wiring.

12 AWG required for distances up to 200'  
14 AWG permitted for distances 0-100'

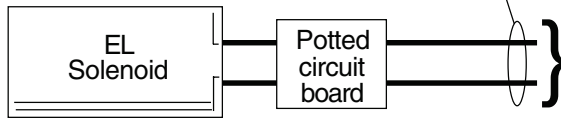

### ELECTRICAL SPECIFICATIONS

Voltage: 24 VDC  
Current: 16 A inrush (0.3 sec.)  
0.25 A holding

### NOTE

When power is applied to the **potted circuit board**, the solenoid receives a momentary signal to retract and a separate signal to hold as long as power is applied. When attempting to retract solenoid again, power must be removed from the circuit and reapplied.

### Troubleshooting solenoid operation

If the solenoid fails to retract the latch bolt when power is applied, recheck wiring for proper connections.

If solenoid retracts latch bolt momentarily but will not remain in energized position:

1. Check wiring for proper connections, gauge, and distances.
2. Check for latch bolt binding caused by improper strike installation, warped door, etc. Also check adjustment of vertical rods.

## EL WIRING

**Solenoid draws 16 A inrush current from PS914. Solenoid must be wired to a 900-2RS logic board:**

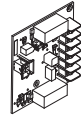

If 900-2RS logic board, refer to instructions 44487056.

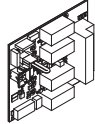

If 900-4RL logic board, refer to instructions 44487080.

Solenoid

Potted Circuit Board  
Install after device has been mounted on door

Do not cut device with potted circuit board installed

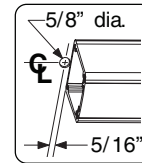
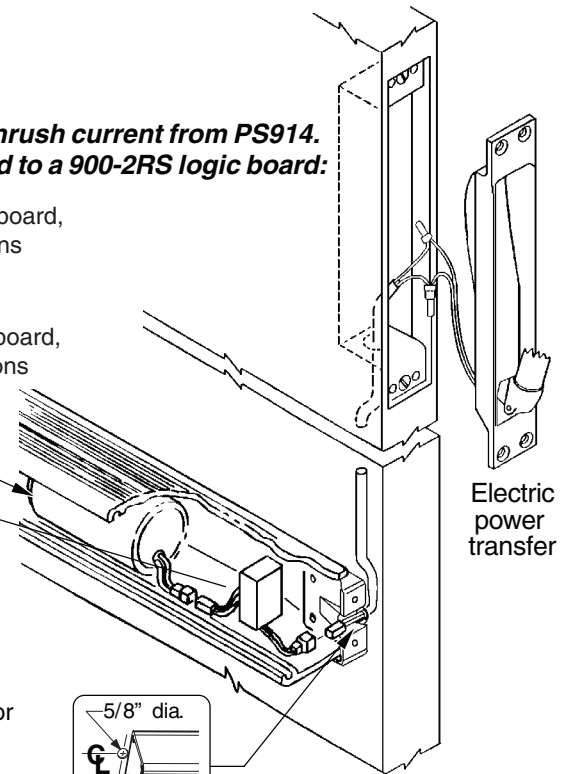

Drill 5/8" dia. wire access hole thru device side of door.

## 13 Adjust EL device for proper function.

### A. Check for proper function:

1. Make sure device is not dogged.
2. Depress pushbar and make sure latch bolt(s) retracts and extends fully (see Figure 13-1).
3. Electrically energize solenoid and hold.
4. Check latch bolt(s) for full retraction (must clear strike, see Figure 13-1).
5. Release solenoid and check latch bolt extension (see Figure 13-1).
6. Continue to Section B if device does not function electrically.

### B. Determine if dogging rod adjustment is too long or short:

1. The dogging rod adjustment is too **long** if latch bolt does not retract and clear strike (see Section C for adjustment).
2. The dogging rod adjustment is too **short** if latch bolt does not fully extend **or** latch bolt fully retracts but solenoid releases while energized (see Section D for adjustment).

### C. Adjust solenoid if dogging rod is too **long** (see Figure 13-2):

1. Remove end cap ① and dogging cover ②.
2. Loosen cap screw ③.
3. Hold plunger ⑤ depressed in solenoid housing ⑥.  
**Note:** Push hard against plunger ⑤ to overcome an internal spring in solenoid housing ⑥.
4. Turn threaded bushing ④ in to shorten dogging rod ⑦ so latch bolt fully retracts.
5. Tighten cap screw ③.  
**Note:** Cap screw ③ must be tightened against flat on threaded bushing ④. Apply a few drops of Loc-Tite 222 to threads of cap screw ③.
6. Replace dogging cover ② and end cap ①.
7. Return to Section A to check for proper function.

**Note:** Rim device shown, see pages 10 and 11 for verticals

Latch bolt extended 3/4"  
Latch bolt retracted Flush within 1/16"



Figure 13-1

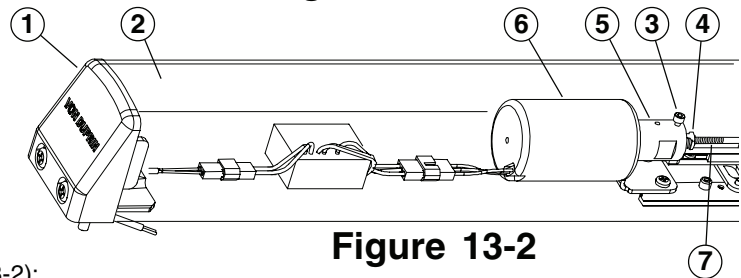

Figure 13-2

### D. Solenoid adjustment if dogging rod adjustment is too **short** (see Figure 13-2):

1. Remove end cap ① and dogging cover ②.
2. Loosen cap screw ③.
3. Hold plunger ⑤ depressed in solenoid housing ⑥.
4. Turn threaded bushing ④ out to lengthen dogging rod ⑦ so plunger ⑤ just bottoms in solenoid housing ⑥ and latch bolt is fully retracted.  
**Note:** Push hard against plunger ⑤ to overcome an internal spring in solenoid housing ⑥.
5. Tighten cap screw ③.  
**Note:** Cap screw ③ must be tightened against flat on threaded bushing ④. Apply a few drops of Loc-Tite 222 to threads of cap screw ③.
6. Replace dogging cover ② and end cap ①.
7. Return to Section A to check for proper function.