



911404-00

33/3547A

VON DUPRIN®

Concealed Vertical Rod Exit Device

Installation Instructions

Devices covered by these instructions:

- 33/3547A and 33/3548A Concealed Vertical Rod Exit Device
- 33/3547A-F and 33/3548A-F Fire Concealed Vertical Rod Exit Device
- CD33/3547A and CD33/3548A Concealed Vertical Rod Exit Device
- EL33/3547A and EL33/3548A Concealed Vertical Rod Exit Device

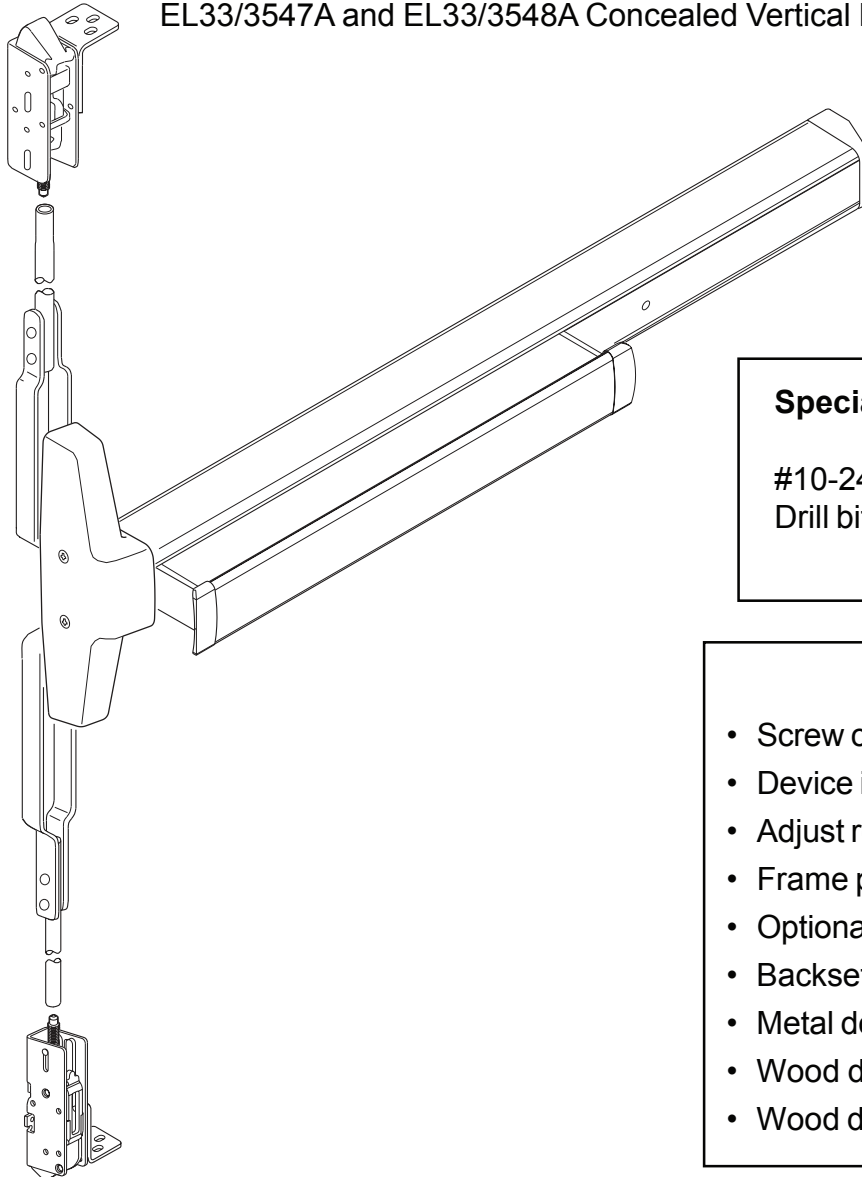

Special tools needed:

- #10-24 tap
- Drill bits: #25, 5/16",
13/32", 1/2"

Index:

- Screw chart 2
- Device installation 3-5
- Adjust rods 6
- Frame preparation 7
- Optional equipment 8
- Backset information 9
- Metal door templates 11-12
- Wood door preparation 13-14
- Wood door templates 15-16



Customer Service

1-877-671-7011 www.allegion.com/us

© Allegion 2016
Printed in U.S.A.
911404-00 07/16-e

SCREW CHART

A

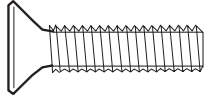
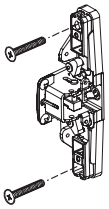

1/4-20 x 1" _____

Trim mount or sex bolts:
(1-3/4" door)

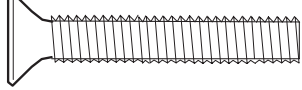

1/4-20 x 1-1/2" _____

(2-1/4" door)

B

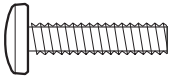
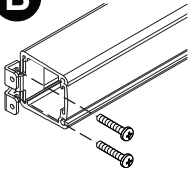

#10-24 X 3/4" _____

Surface mount or
Sex bolts (1-3/4" door)

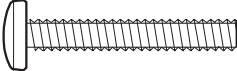

#10-24 X 1-1/8" _____

Sex bolts (2-1/4" door)

C



#10-16 X 3/8" Thread cutting _____

End cap

D

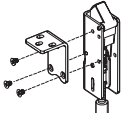

#10-32 X 1/4" _____

Bracket to latch

E

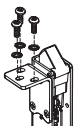

*#10-24 X 1/2" _____

Bracket to door

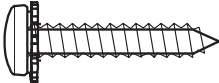

*#10 X 1" Wood screw _____

Bracket to door

*Used with external tooth lock washer

F



#10-32 X 3/8" Socket head _____

Rod attachment

G

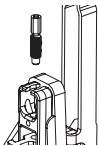

Rod adjusting screw _____

Rod length adjustment

H

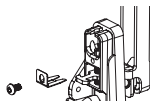

#8-32 X 5/16" _____

Retaining clip

I

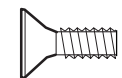
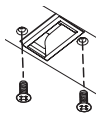

#10-24 X 1/2" _____

338 Strike

J

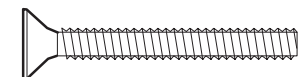

#10-24 X 1-1/2" _____

Ratchet release

K

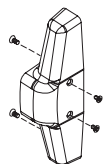

#8-18 x 3/8" Thread cutting _____

Center case cover

1

Draw horizontal and vertical device center lines (☉).

See "Backset information" on page 9

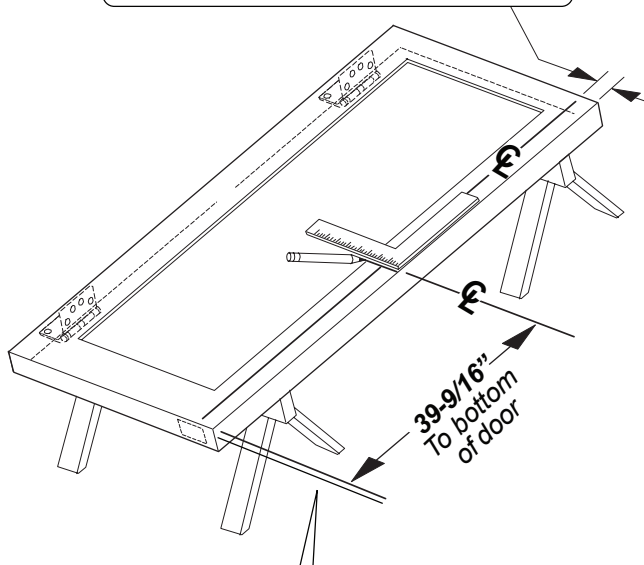

Once hung, door should have 1/4" undercut (gap) at bottom of door to finished floor

RHR shown (LHR opposite)

2

Place paper device template on door and prepare door.

For wood doors - See pages 13 & 14 for special door preparation instructions.

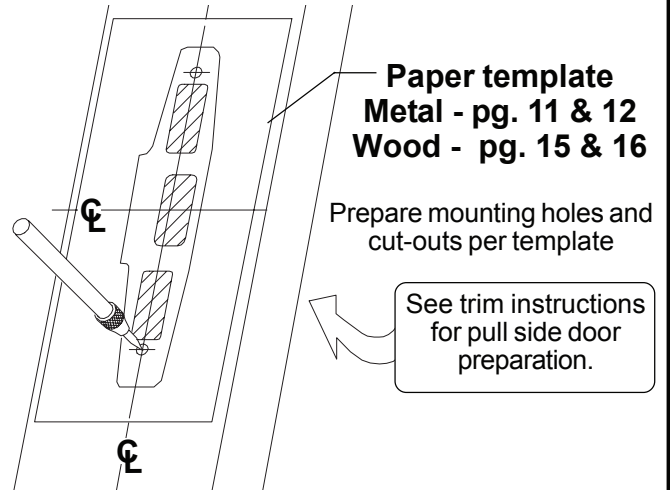

Paper template
Metal - pg. 11 & 12
Wood - pg. 15 & 16

Prepare mounting holes and cut-outs per template

See trim instructions for pull side door preparation.

RHR shown (LHR opposite)

3

Prepare top and bottom of door for latch mounting brackets.

Latch cases (drill top and bottom of door)

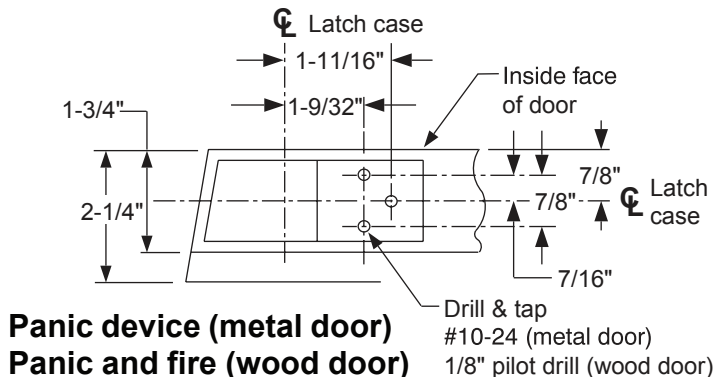
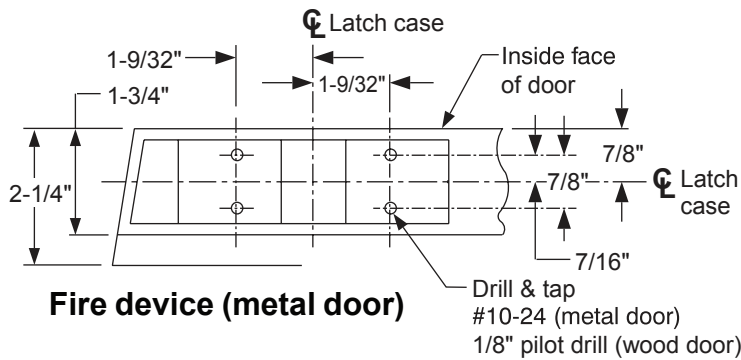

4

Drill ratchet release hole in door.

11/16"	1/2" Stop height
13/16"	5/8" Stop height
15/16"	3/4" Stop height

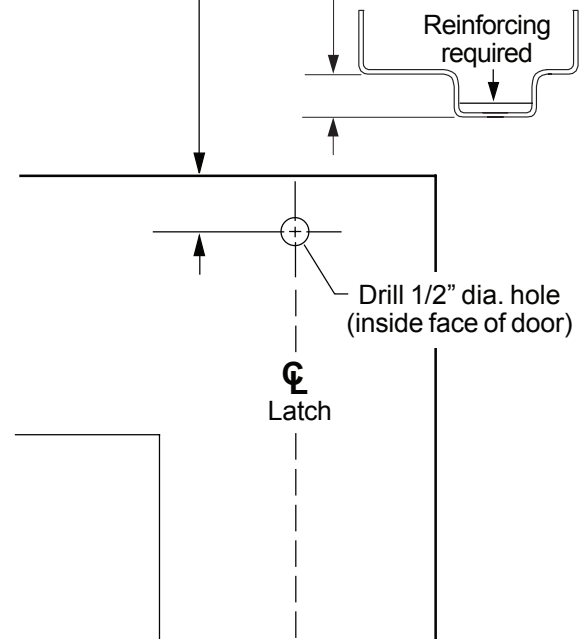

5

Measure to determine length to cut device.

1-3/16" minimum clearance
(with end cap removed)

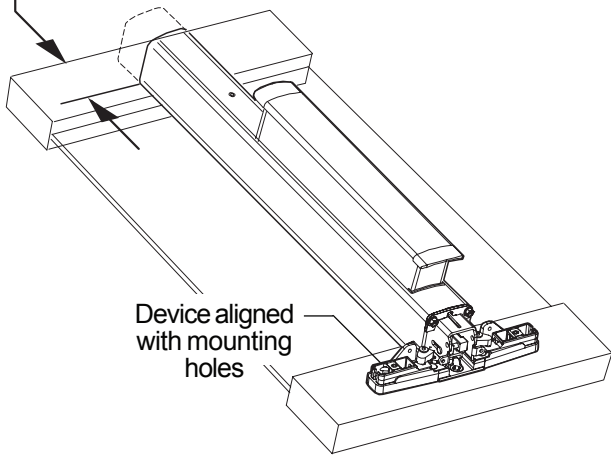

Device aligned with mounting holes

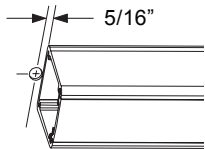

Note

If 5/8" diameter wire access hole has been predrilled in door, cut device 5/16" from center of hole.

6

Cut device to length.

Prepare device for cutting

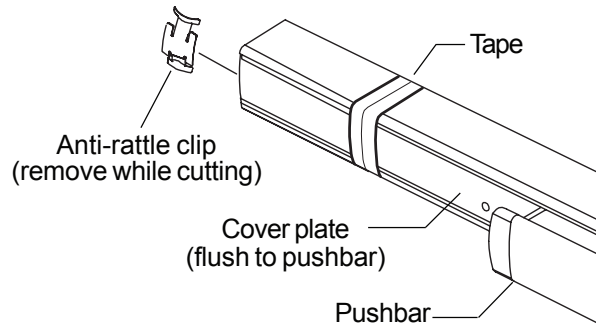

Anti-rattle clip
(remove while cutting)

Cover plate
(flush to pushbar)

Pushbar

Cut device square

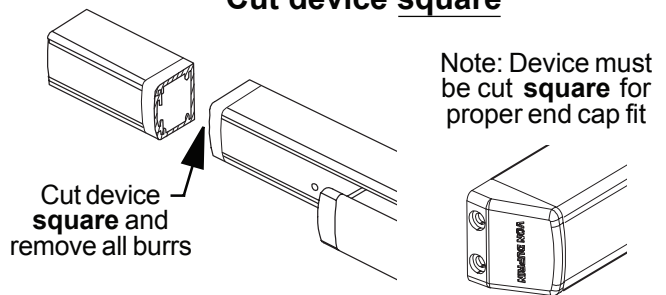

Note: Device must be cut **square** for proper end cap fit

Cut device **square** and remove all burrs

7

Assemble rods and latches and adjust length.

Follow white and brown instruction cards on rods to set initial rod length

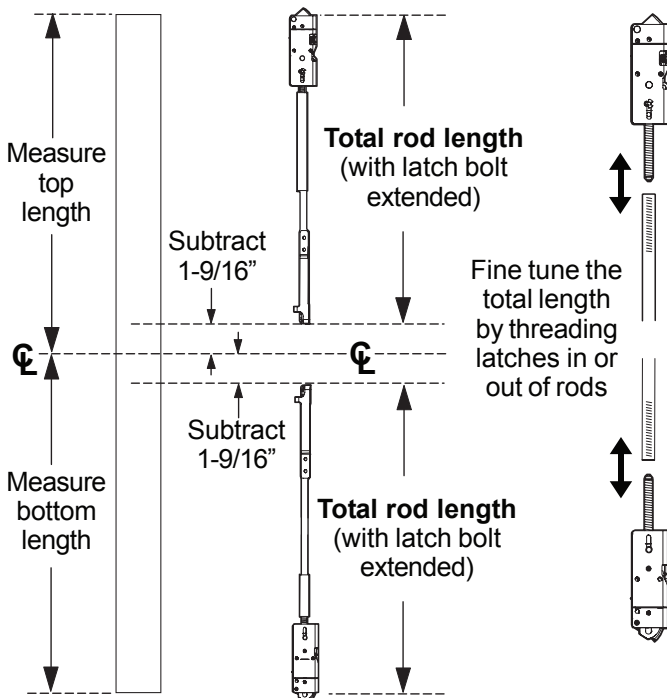

Measure top length

Total rod length
(with latch bolt extended)

Subtract 1-9/16"

Fine tune the total length by threading latches in or out of rods

Measure bottom length

Subtract 1-9/16"

Total rod length
(with latch bolt extended)

8

Install rods as shown.

Rods are shipped with L-bracket attached. Insert rods with L-bracket pointing toward lock stile. Rotate rod until L-bracket protrudes through door cutout. If this is not possible, remove L-bracket and re-insert rod, then re-attach L-brackets.

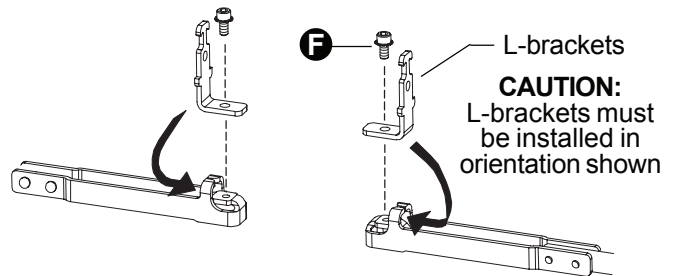

F

L-brackets

CAUTION:
L-brackets must be installed in orientation shown

NOTE: Fire devices on metal doors use brackets on both sides of latches

Top latch & rod

Bottom latch & rod

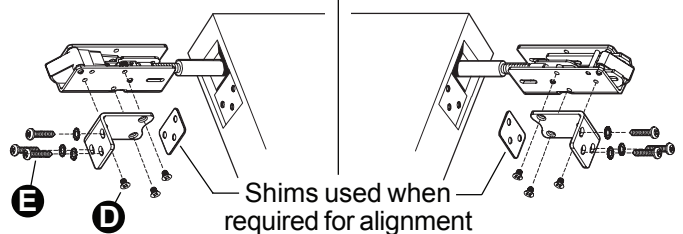

Shims used when required for alignment

9

Install tailpiece guide and attach rods to center case.

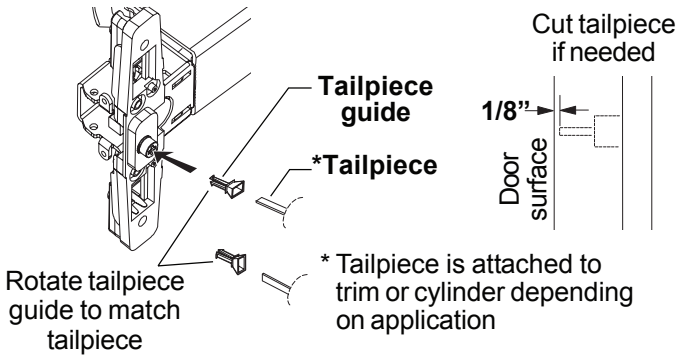

Place device over L-brackets and install adjusting screws, then install retainers and locking screws

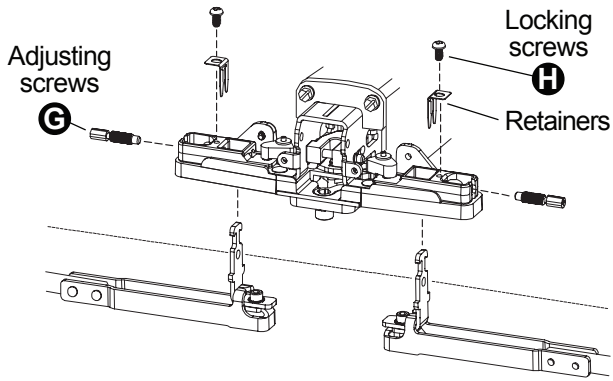

10

Secure device to door and mount door to frame.

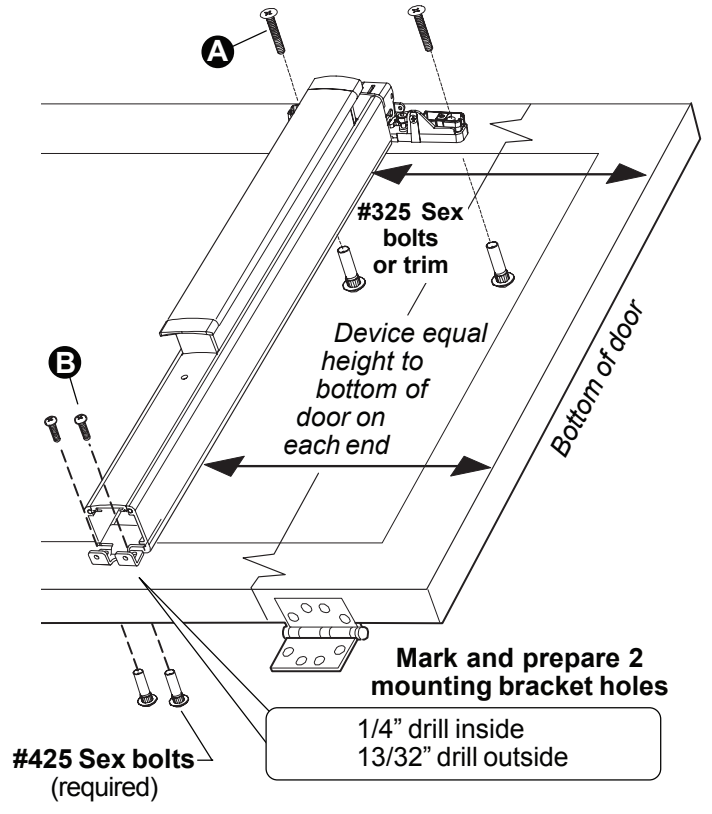

11

Install top strike and ratchet release.

338 Top strike

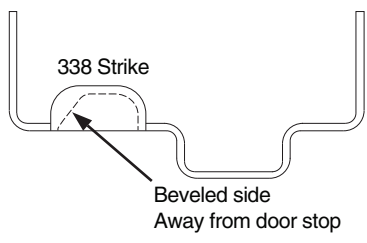
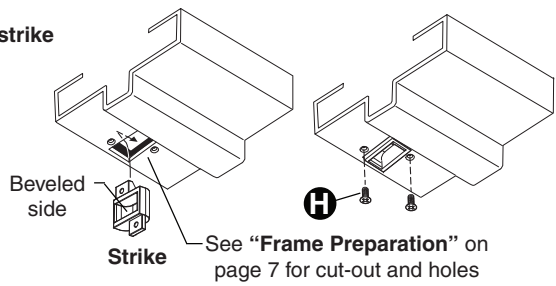

Ratchet release

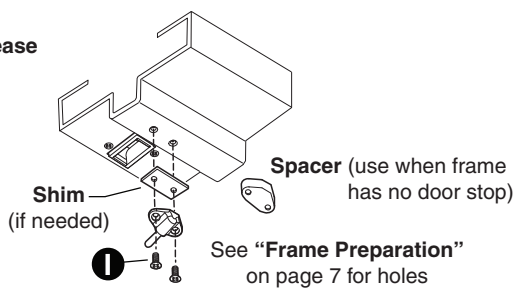

12

Install bottom strike or prepare threshold.

385-A Bottom strike

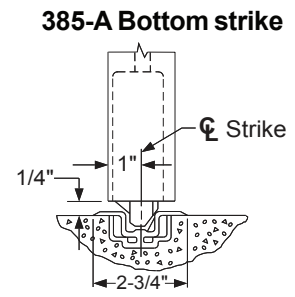

385-A strike has two pieces. Grout bottom piece into floor and attach top piece to bottom with screw through slot.

Threshold application

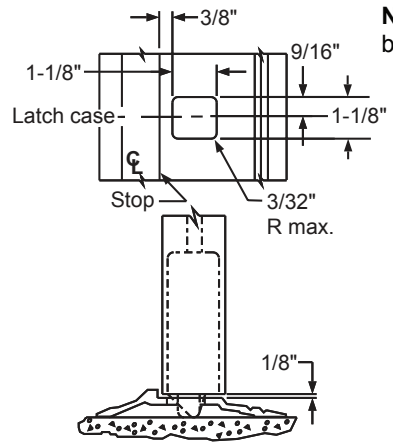

Note: Thresholds are not to be used with 33/3547A-F

Flat threshold application

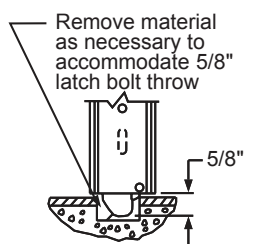

ADJUST RODS

1. Open door and release top latch bolt as shown (Figure 1).

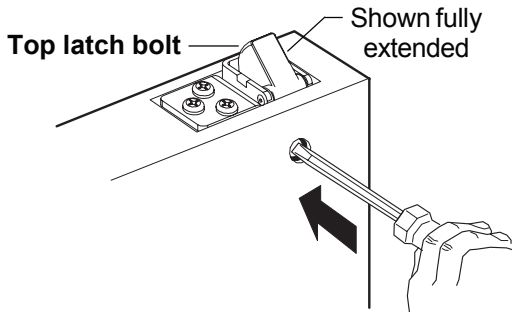

Figure 1

2. Remove bottom locking screw and retaining clip (Figure 2).
3. Disconnect bottom vertical rod by removing bottom adjusting screw.
4. Loosen top locking screw.
5. Rotate top adjusting screw clockwise until top latch bolt is fully extended (Figure 1).

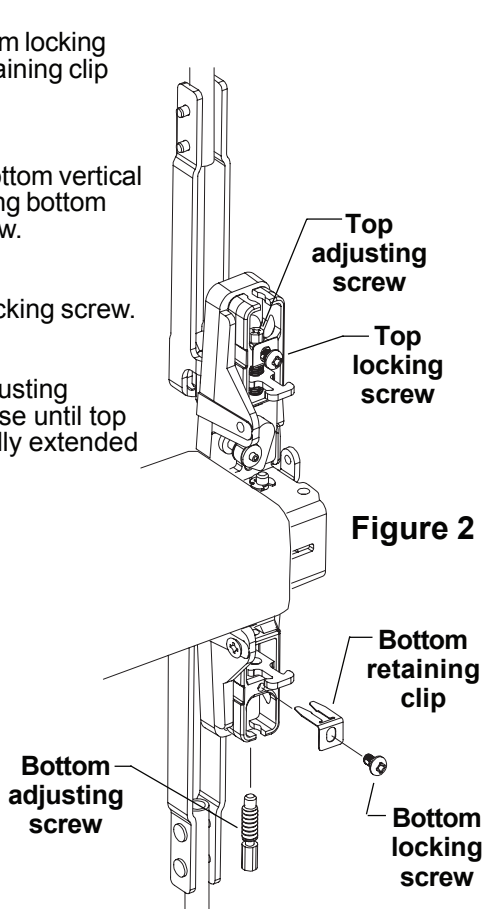
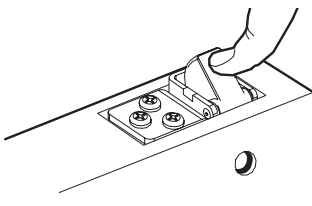

Figure 2

6. Check top latch bolt for deadlocking (latch bolt should not push in).



7. Turn top locking screw in against flat on adjusting screw. Do not over-tighten.

8. Depress pushbar and release.

9. Make sure top latch bolt stays retracted as shown.

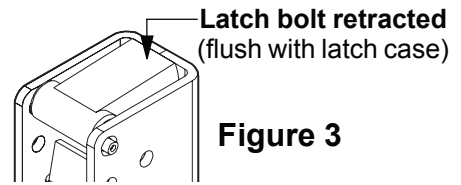

Figure 3

10. Install bottom adjusting screw through bottom rod and install bottom retaining clip and locking screw (Figure 2).

11. With top latch bolt still retracted, adjust bottom rod so latch bolt clears floor and bottom strike.

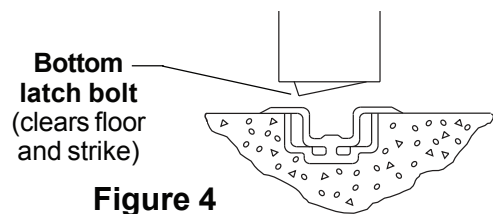

Figure 4

12. Close door and check bottom latch bolt for dead locking.

13. After bottom rod is fully adjusted per steps 11 and 12, turn bottom locking screw in against flat on adjusting screw. Do not over-tighten.

14. Check device operation by opening and closing door several times from the outside.

Redo adjustment procedure if :

- Top latchbolt is not held retracted
- Bottom latchbolt does not clear floor and bottom strike

15. Install end cap and center case covers.

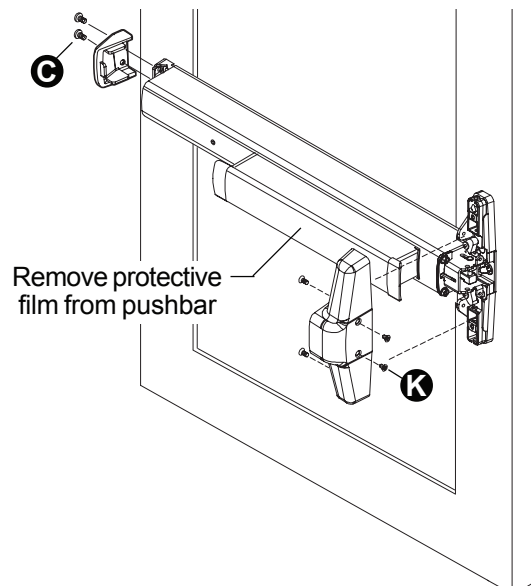

FRAME PREPARATION

338 Top strike

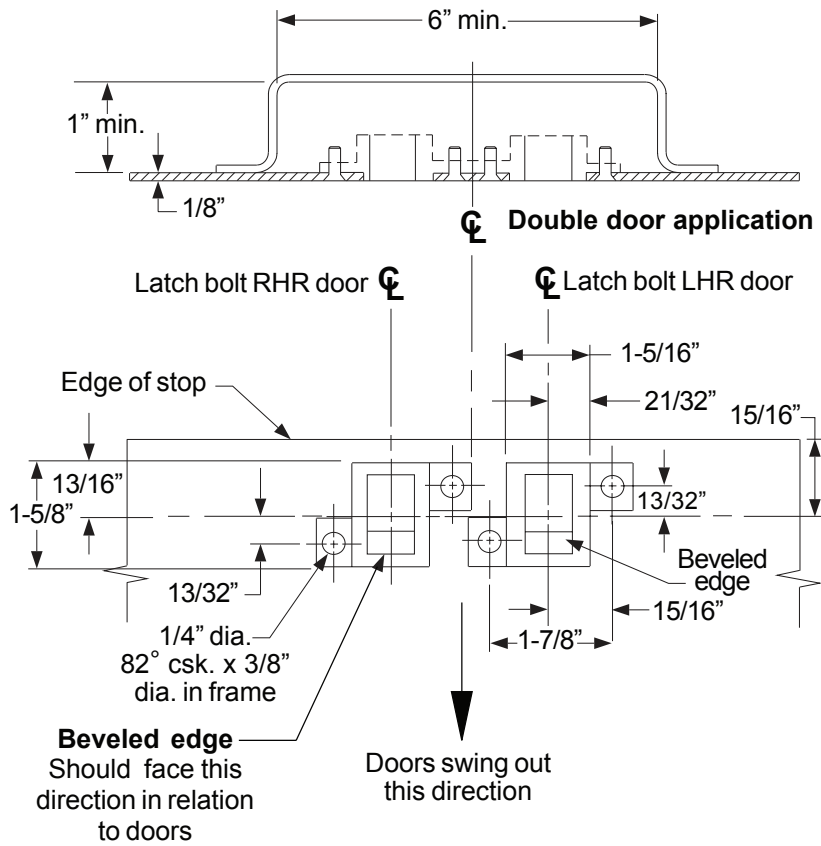

Ratchet release

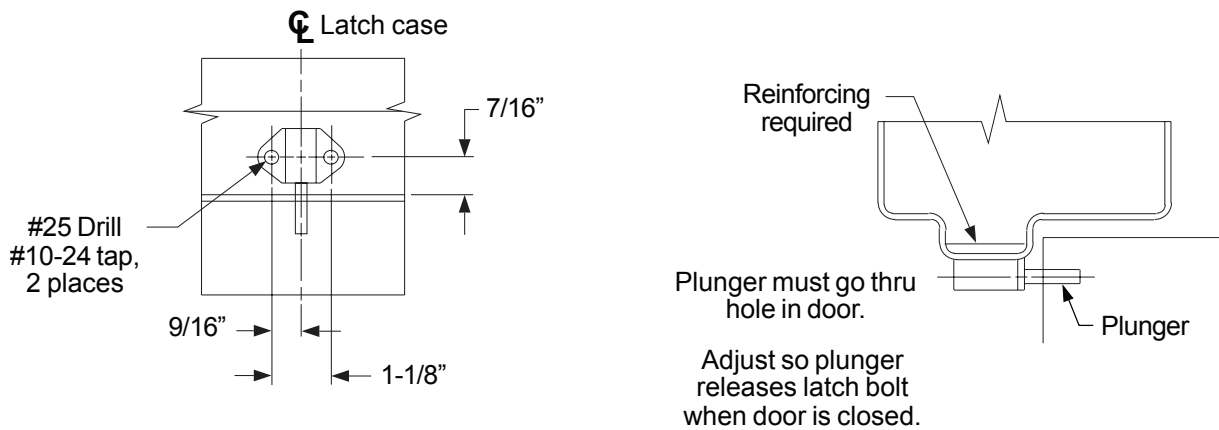

OPTIONAL EQUIPMENT

CD (CYLINDER DOGGING)

1. Remove mortise cylinder cam and reinstall in reverse (Figure 1).
2. Insert key and rotate cam to install the cylinder to the cover plate (Figure 2).
3. Remove key to slide cover plate in position in the mechanism case.

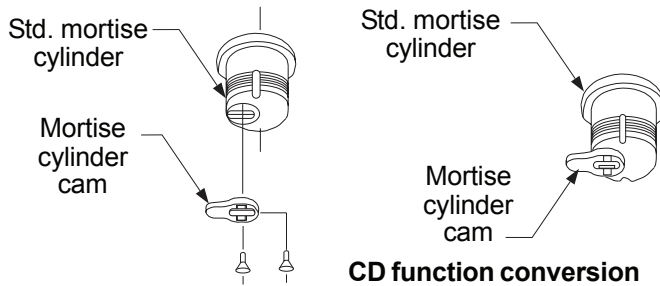

Figure 1

Dogging procedure

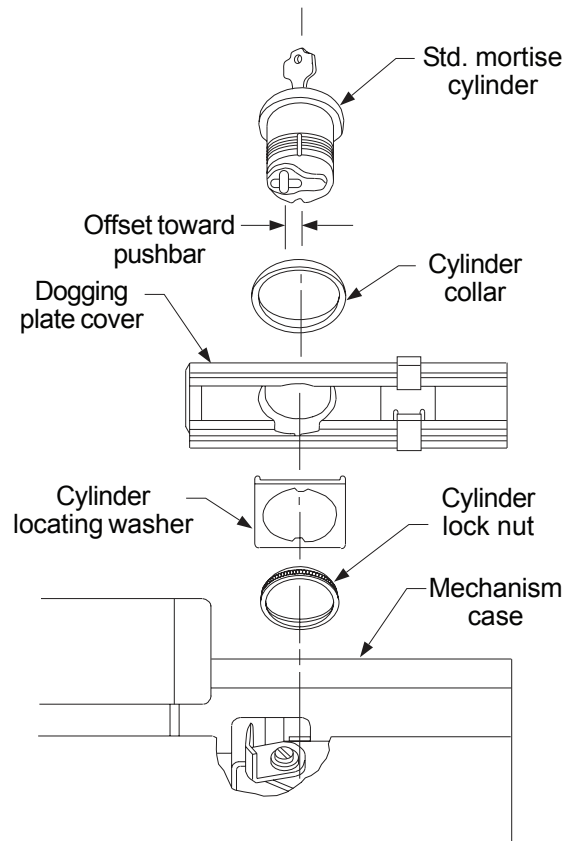
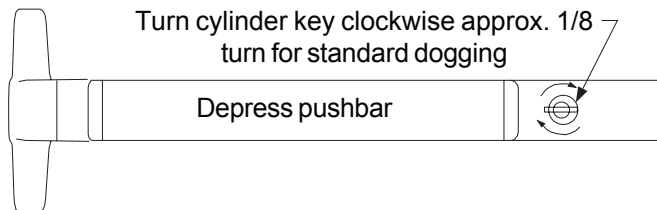
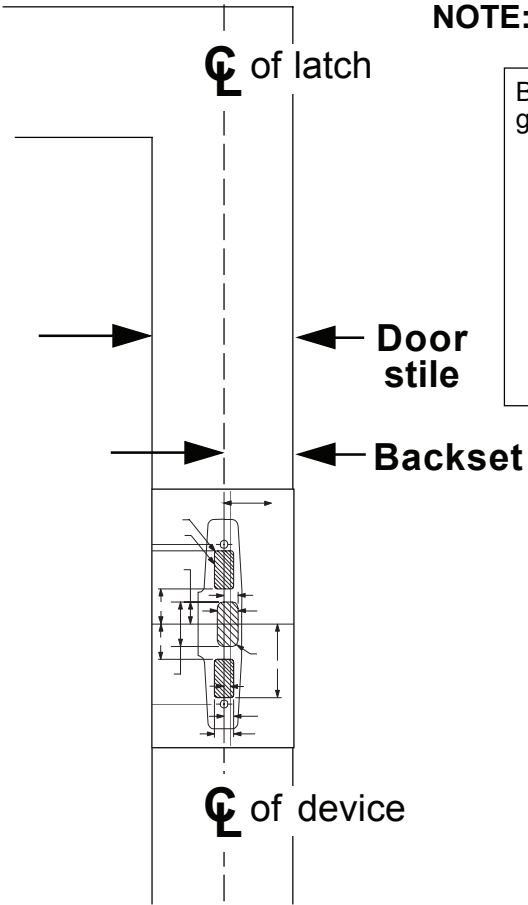

Figure 2

BACKSET INFORMATION

NOTE: For 2" stile doors see bottom half of page



Backset is measured from outer edge of door as shown. Minimum stile is less glass stop (rectangular glass stop is recommended for stiles less than 2-1/8")

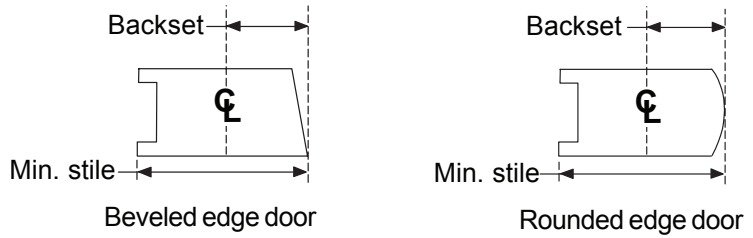

Backset Table

Door type	Backset	Min. stile	Application
Wood	1-5/16"	NA	All
Metal	1-3/16"	2-1/8" - 2-3/4"	Two vertical rod devices (panic)
	1-1/2"	2-3/4" - 3-3/4"	
	1-7/8"	3-3/4" - 5"	
	2-1/2"	5" to flush	
Metal	1-1/2"	2-1/2" - 3-3/4"	Single door (panic)
	1-7/8"	3-3/4" - 5"	
	2-1/2"	5" to flush	
Metal	2-3/4"	3-5/8" to flush	Fire applications

SPECIAL INSTRUCTIONS FOR 2" STILE DOORS

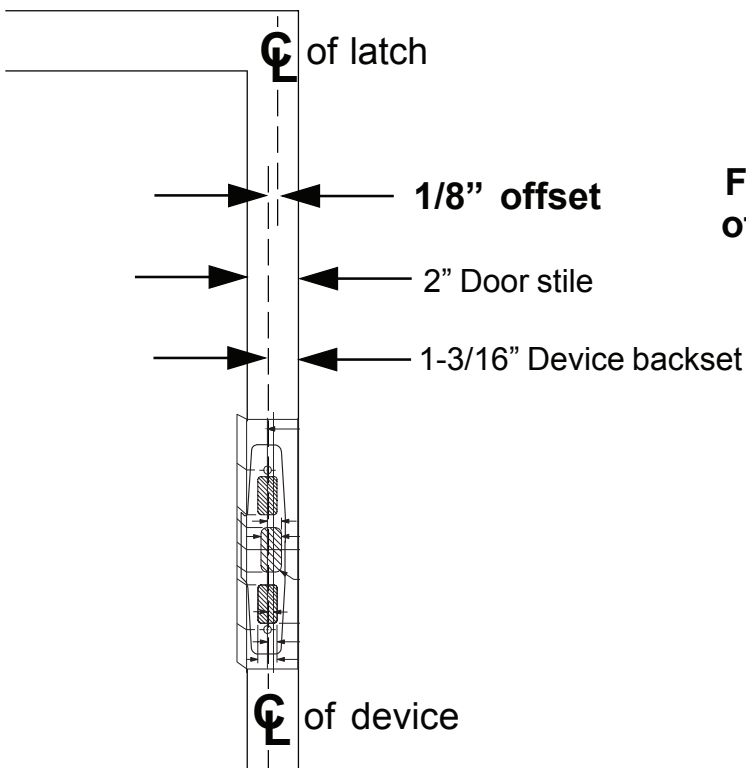

For 2" stile doors ONLY! Latch CL is offset 1/8" from Device CL as shown

This page
intentionally
left blank

METAL DOOR RHR

33/3547A Device template

X

RHR

Backset

See "Backset Information" on page 9

Device ϕ

1/8" Radius

Cut-outs device side only

Sex bolts	5/16" drill inside 13/32" drill outside
Trim	5/16" drill inside 1/2" drill outside

For 3347A-F on hollow metal doors #7 drill, 1/4-20 tap if no outside trim or sex bolts are used.

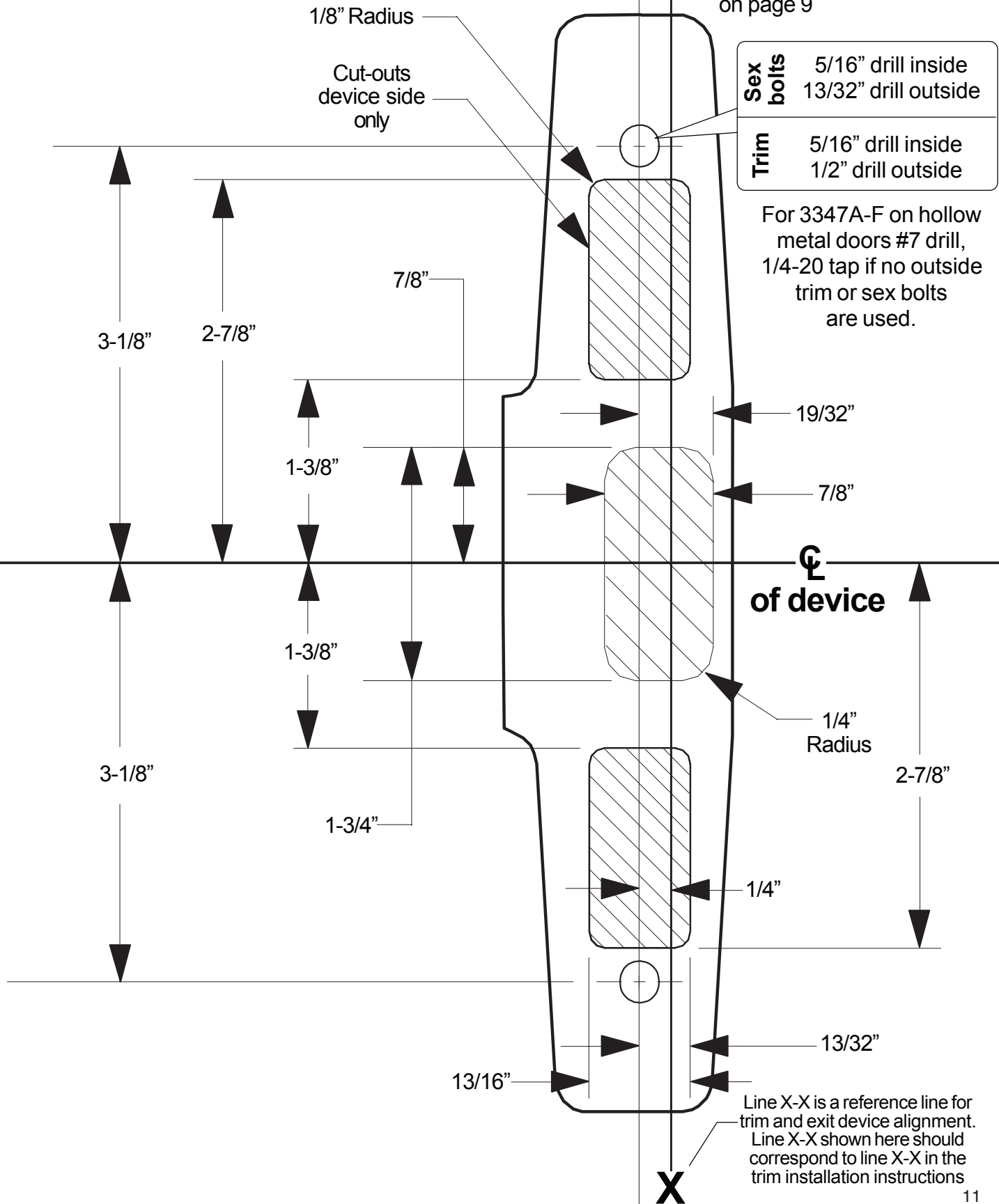

Line X-X is a reference line for trim and exit device alignment. Line X-X shown here should correspond to line X-X in the trim installation instructions

LHR

METAL DOOR LHR

33/3547A Device template

← Backset →

See "Backset Information" on page 9

☉ of device

Sex bolts	5/16" drill inside 13/32" drill outside
Trim	5/16" drill inside 1/2" drill outside

For 3347A-F on hollow metal doors #7 drill, 1/4-20 tap if no outside trim or sex bolts are used.

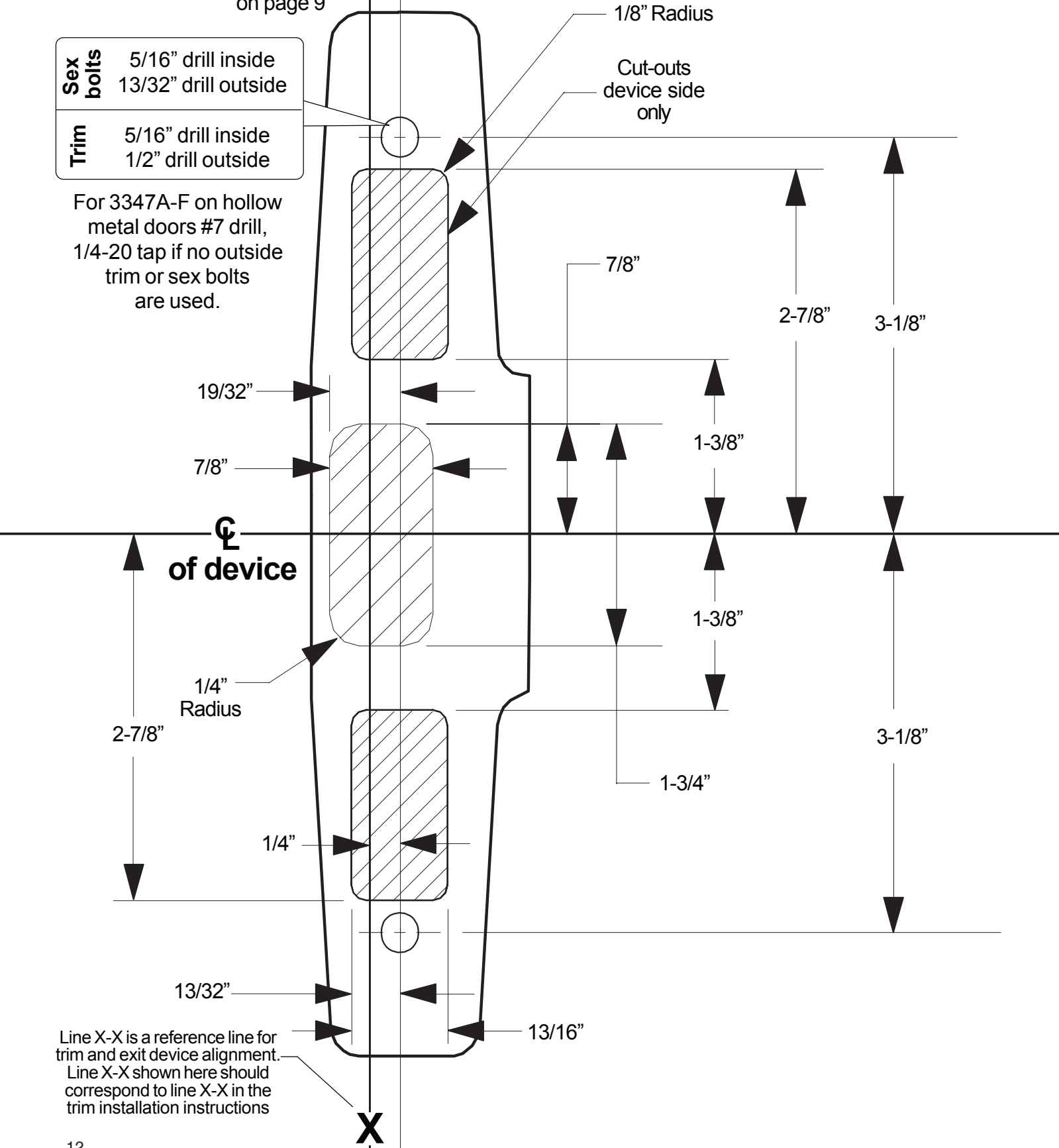

Line X-X is a reference line for trim and exit device alignment. Line X-X shown here should correspond to line X-X in the trim installation instructions

WOOD DOOR PREPARATION - DOOR ROUTING

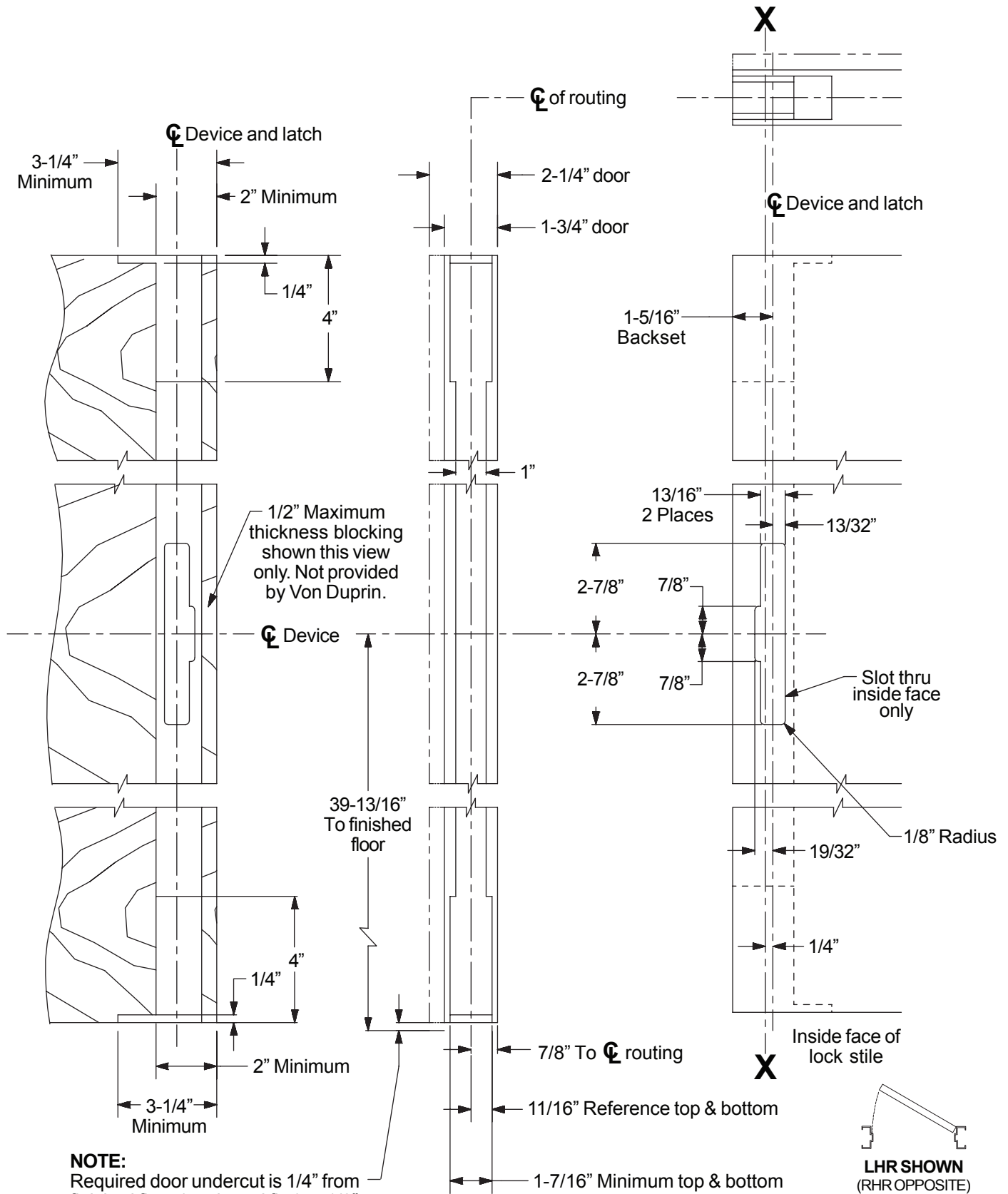

WOOD DOOR PREPARATION - DOOR BLOCKING AND WRAP

A. Install door blocking. See page 13 for door blocking dimensions.

Note: If not using door wrap, the blocking can be installed after device is installed.

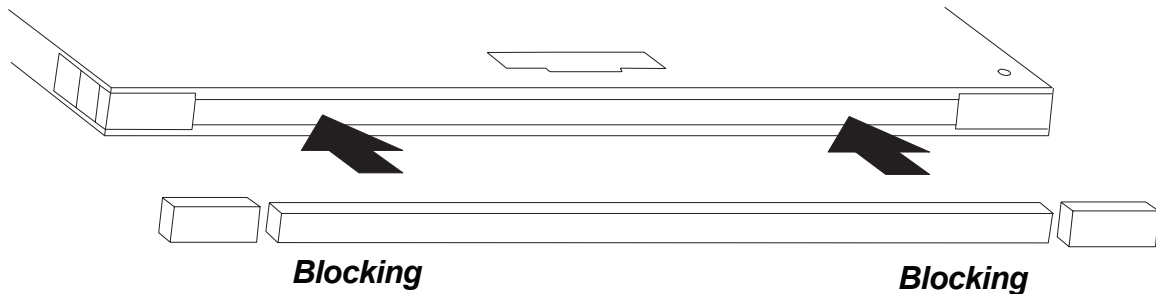

B. Install door wrap if needed. Door wrap is required for Fire rated (F) devices.

Note: Required on fire doors only, not supplied by Von Duprin
(See door manufacturer's requirements)

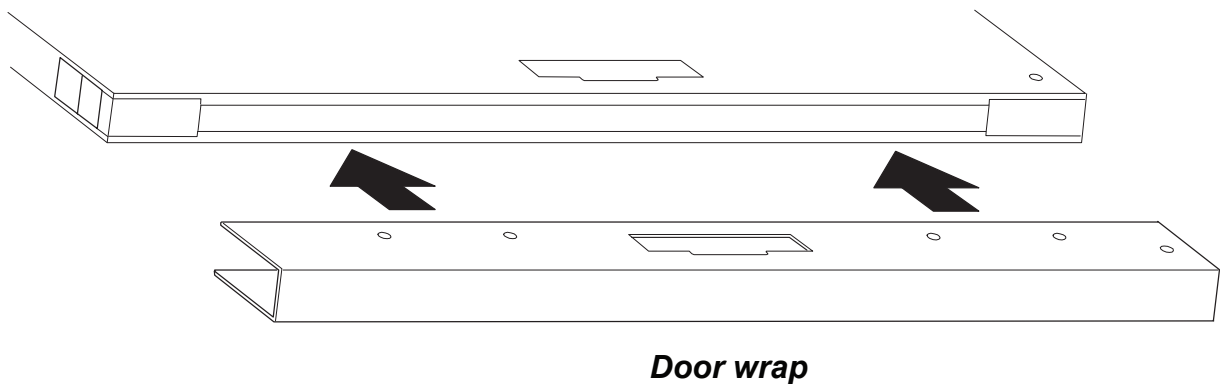

WOOD DOOR RHR 33/3547A Device Template

RHR

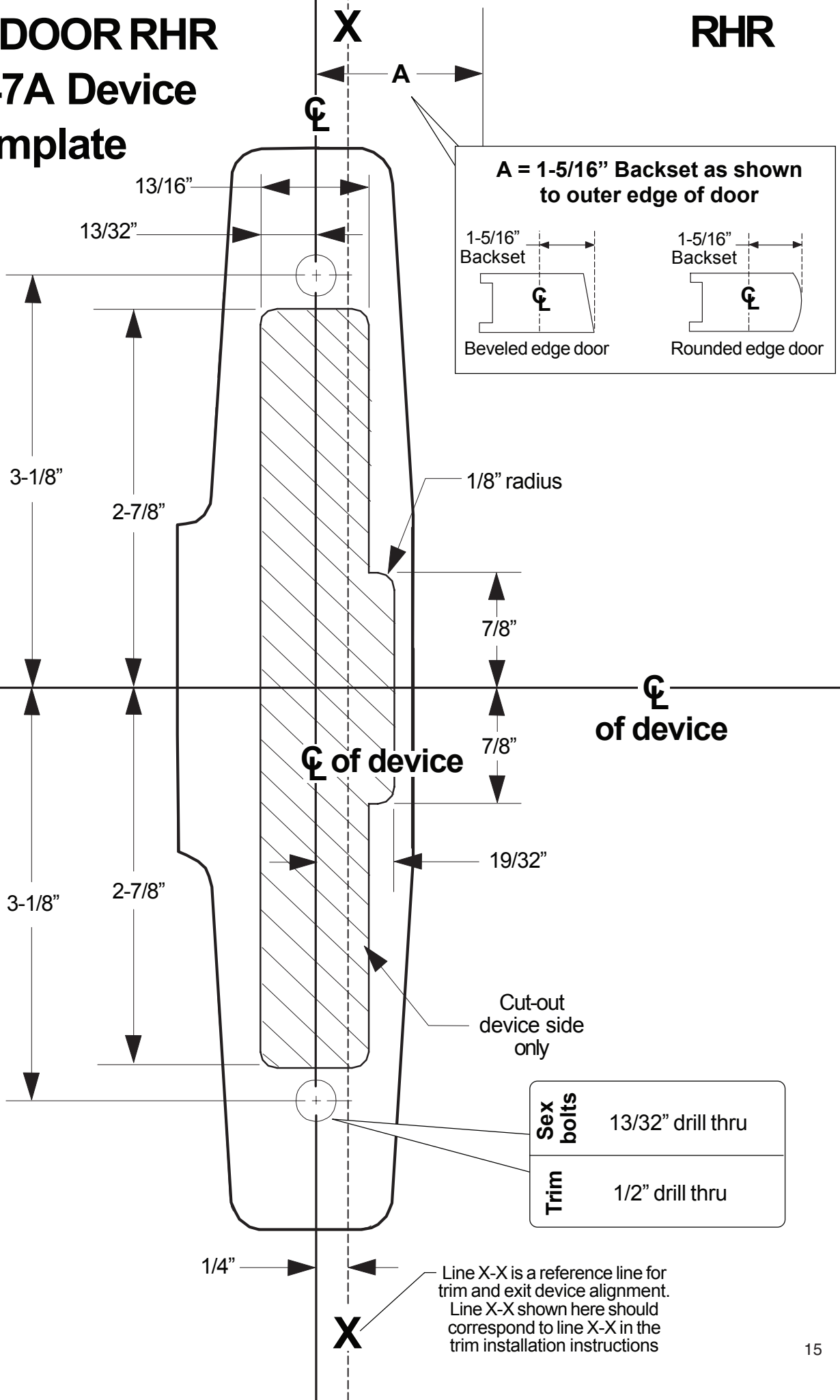

Sex bolts	13/32" drill thru
Trim	1/2" drill thru

Line X-X is a reference line for trim and exit device alignment. Line X-X shown here should correspond to line X-X in the trim installation instructions

LHR

WOOD DOOR LHR 33/3547A Device Template

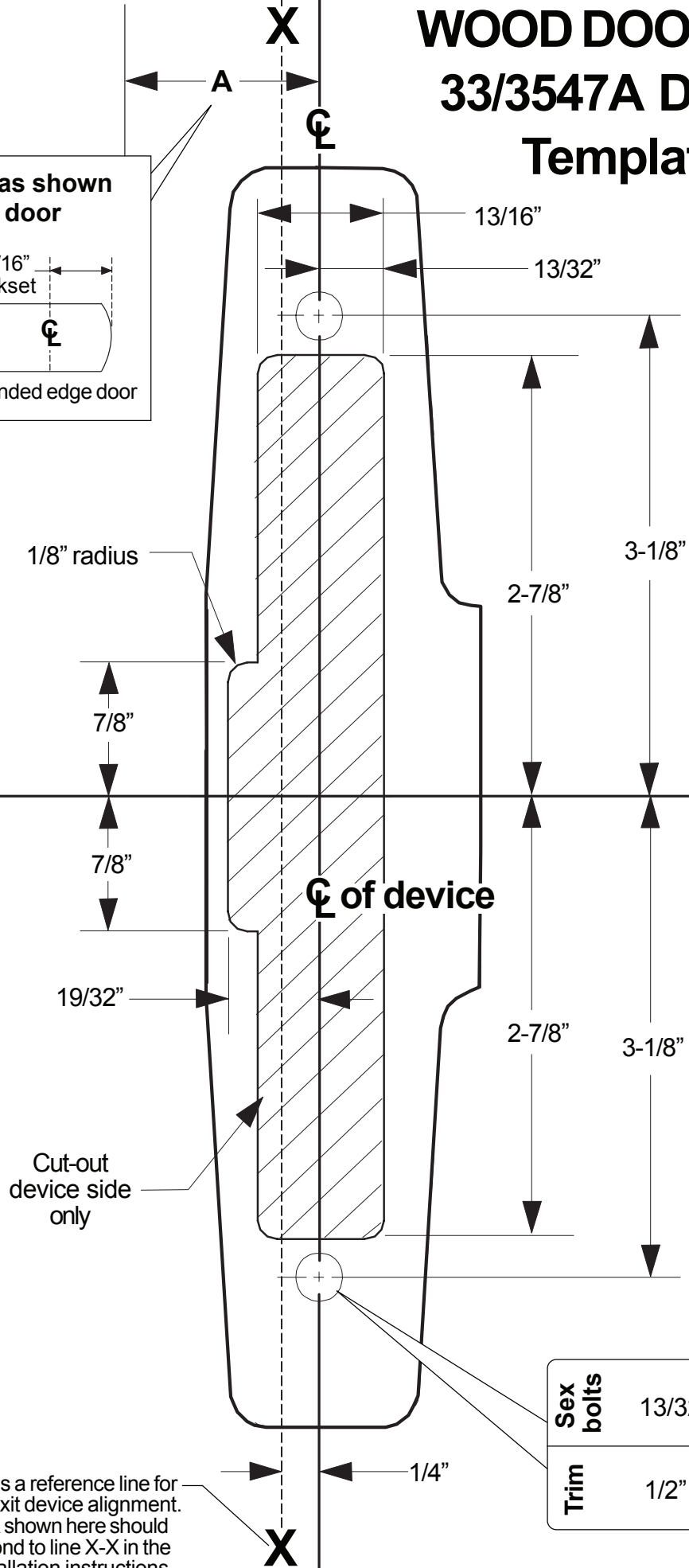
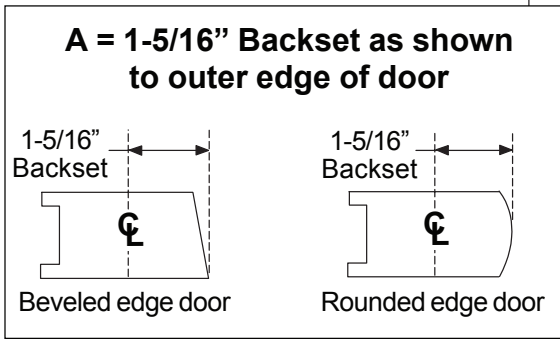

Line X-X is a reference line for trim and exit device alignment.
Line X-X shown here should correspond to line X-X in the trim installation instructions

Sex bolts	13/32" drill thru
Trim	1/2" drill thru



941255-00

EL/HD-EL

VON DUPRIN®

Conversion Kit

Installation Instructions

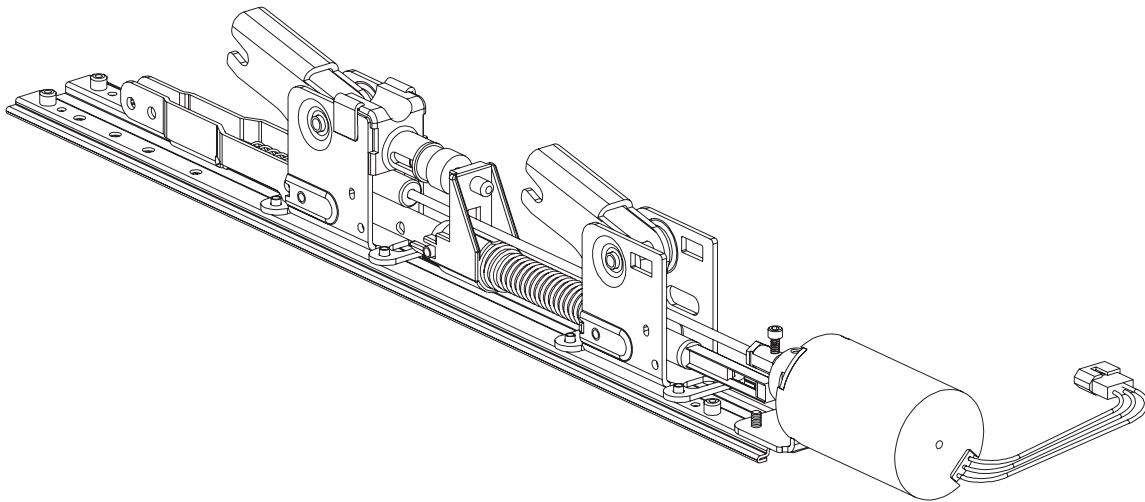

Read All Warnings
Before Starting Installation!

Index

- General Information 2
- Specifications 2
- Parts List 2
- Warnings 2
- Tools Needed 2
- Installation 3
- EL Wiring and Adjustment 12

Customer Service

1-877-671-7011 www.allegion.com/us



© Allegion 2014
Printed in U.S.A.
941255-00 Rev. 01/14-c

GENERAL INFORMATION

This kit converts 33/35, 33A/35A, and 98/99 series devices to electric latch (EL) retraction devices. Before beginning installation, review “Specifications,” “Parts List,” “Warnings,” and “Tools Needed.”

SPECIFICATIONS

Solenoid:

Continuous duty: 24 VDC

Current inrush: 16 A

Current holding: 0.3 A

PARTS LIST

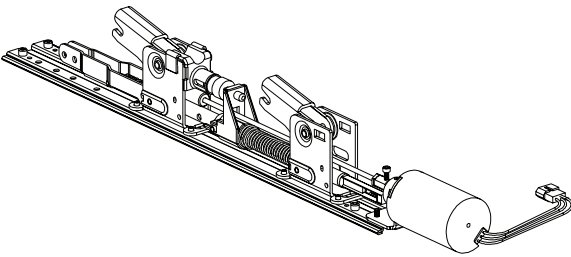

Baseplate with solenoid

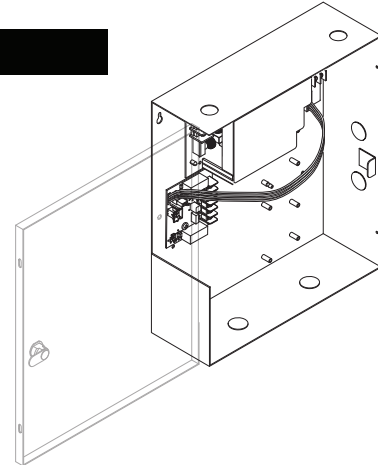

PS914 power supply with 900-2RS logic board
*not in kit



Pin and retaining clip

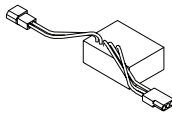

Circuit breaker

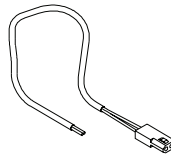

Cable

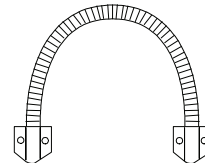

DL-12 door loop
*not in kit

* This part is required for installation but not included in this kit. Contact factory to order.

WARNINGS

1. This kit cannot be used to convert 33/35 Rim devices. Consult factory.
2. Install according to instructions or device will not function and panic or fire label will be void.
3. The solenoid wiring must be attached to the fire alarm system if installed on fire exit hardware.
4. PS914 power supply with 900-2RS logic board must be used for EL device to operate properly.
5. Field wiring between the power supply and the door must be 12 AWG.

TOOLS NEEDED



5/8" dia. drill bit



Flat blade screwdriver

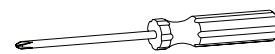

Phillips screwdriver

1 Remove device from door if installed (find correct device on page 3 or 4).

⚠ WARNING

Device and trim must be held securely while removing mounting screws to prevent device and trim from dropping to the floor.

98/99 Rim/Mortise Device

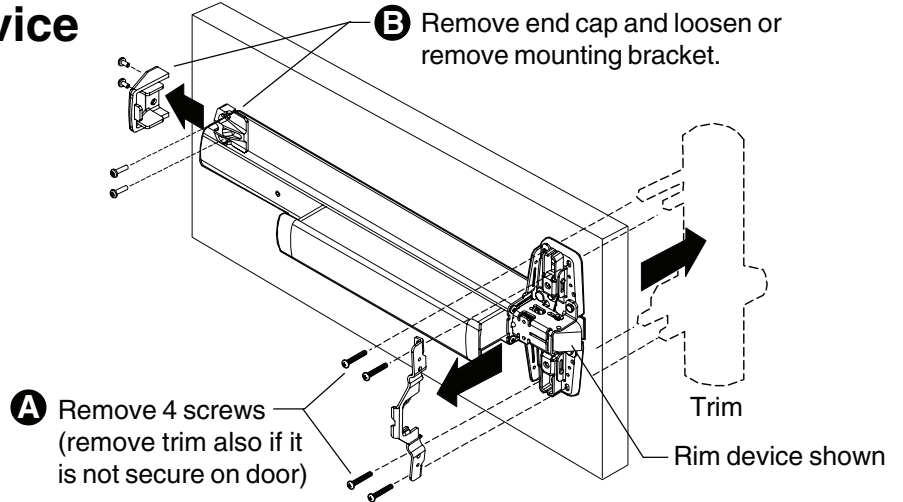

9827/9927 Device

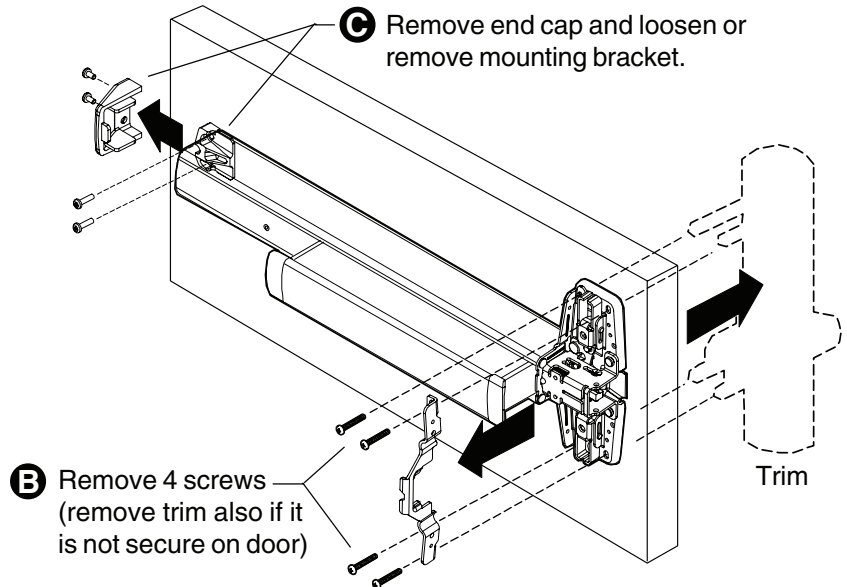
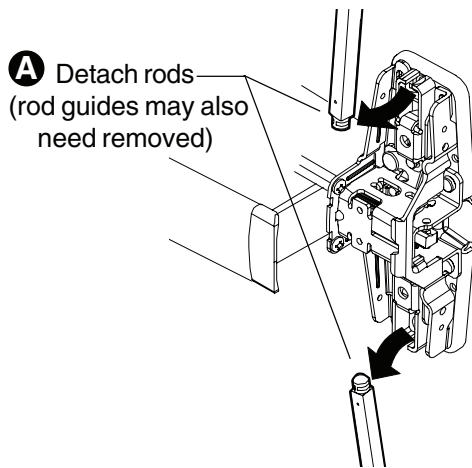

9847/9947 Device

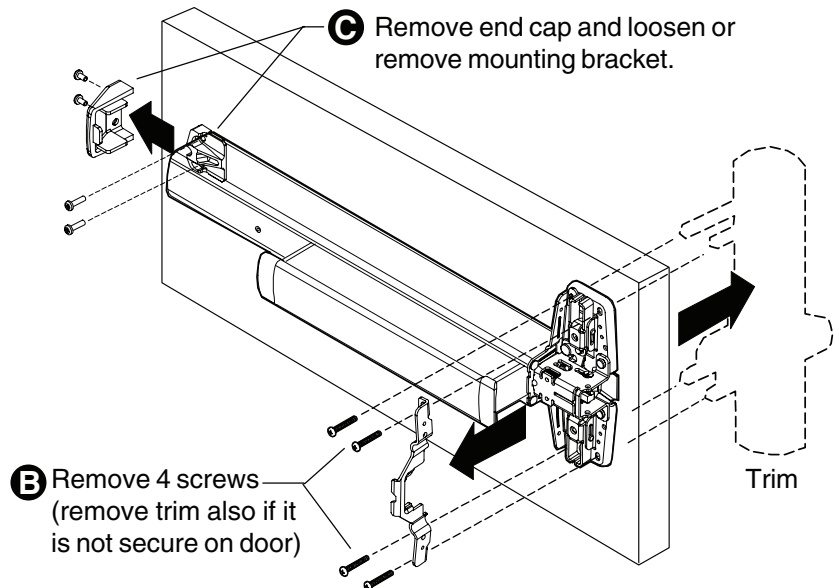
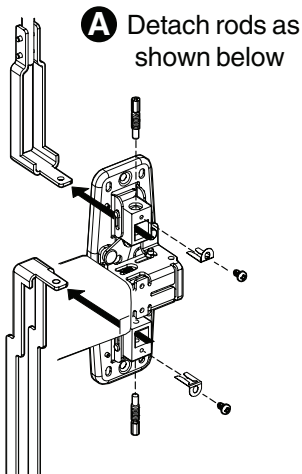

33A/35A Rim Device

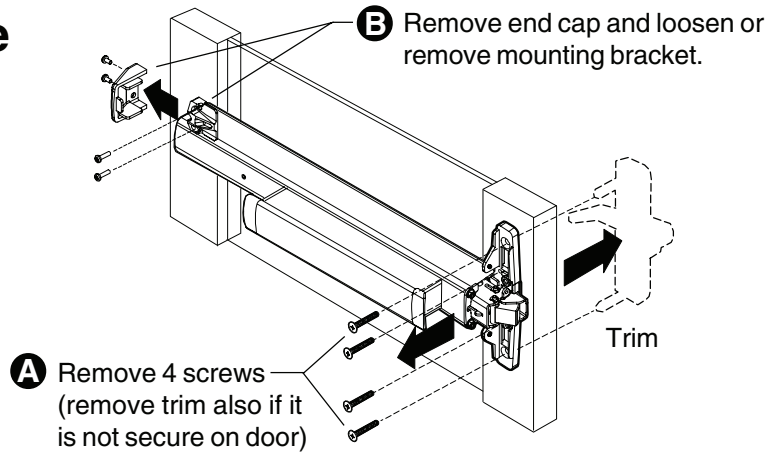

3327/3527 & 3327A/3527A Device

A Detach rods (rod guides may also need removed)

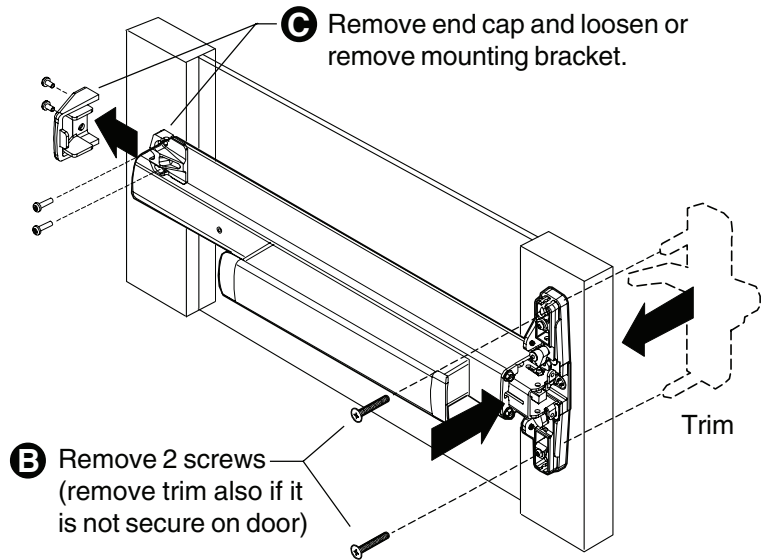
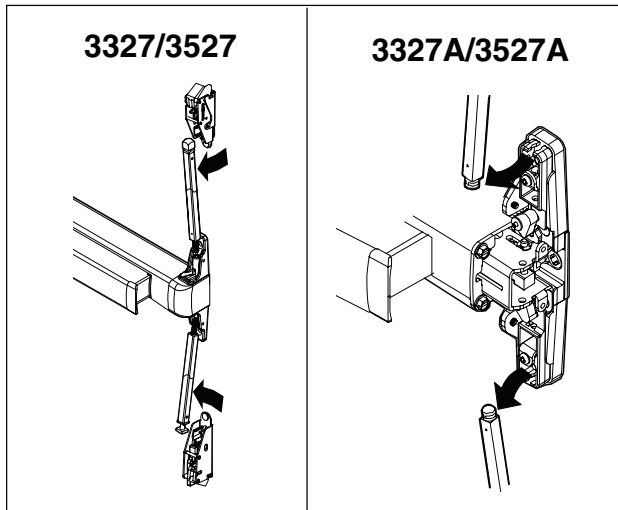

3347/3547 & 3347A/3547A Device

A Detach rods as shown below

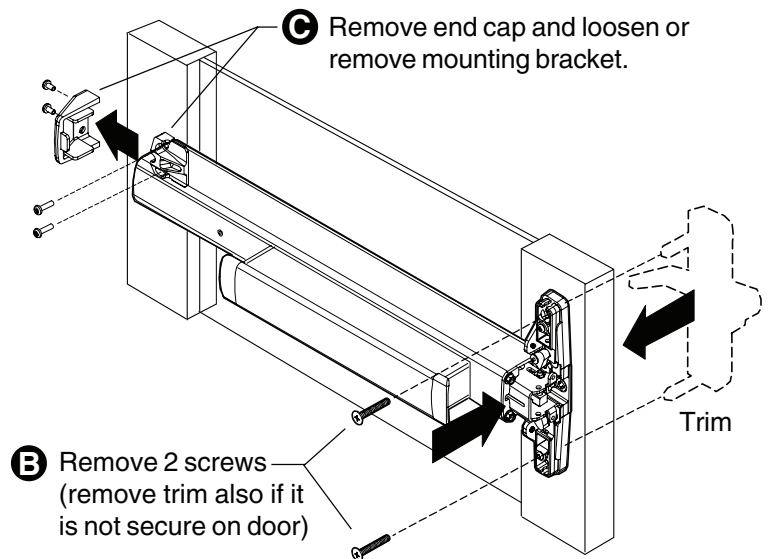
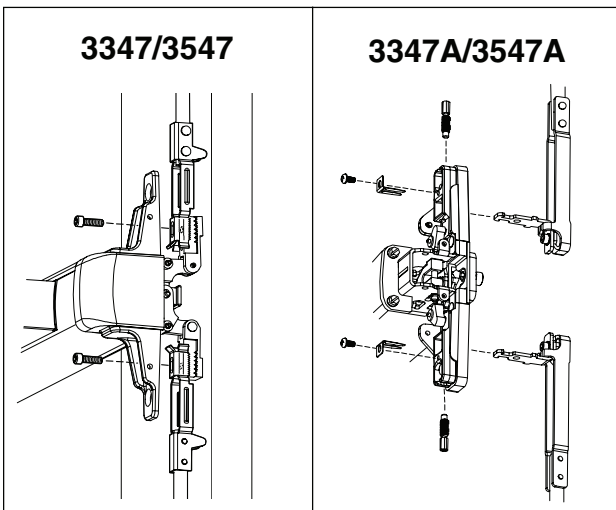

33/35 Device

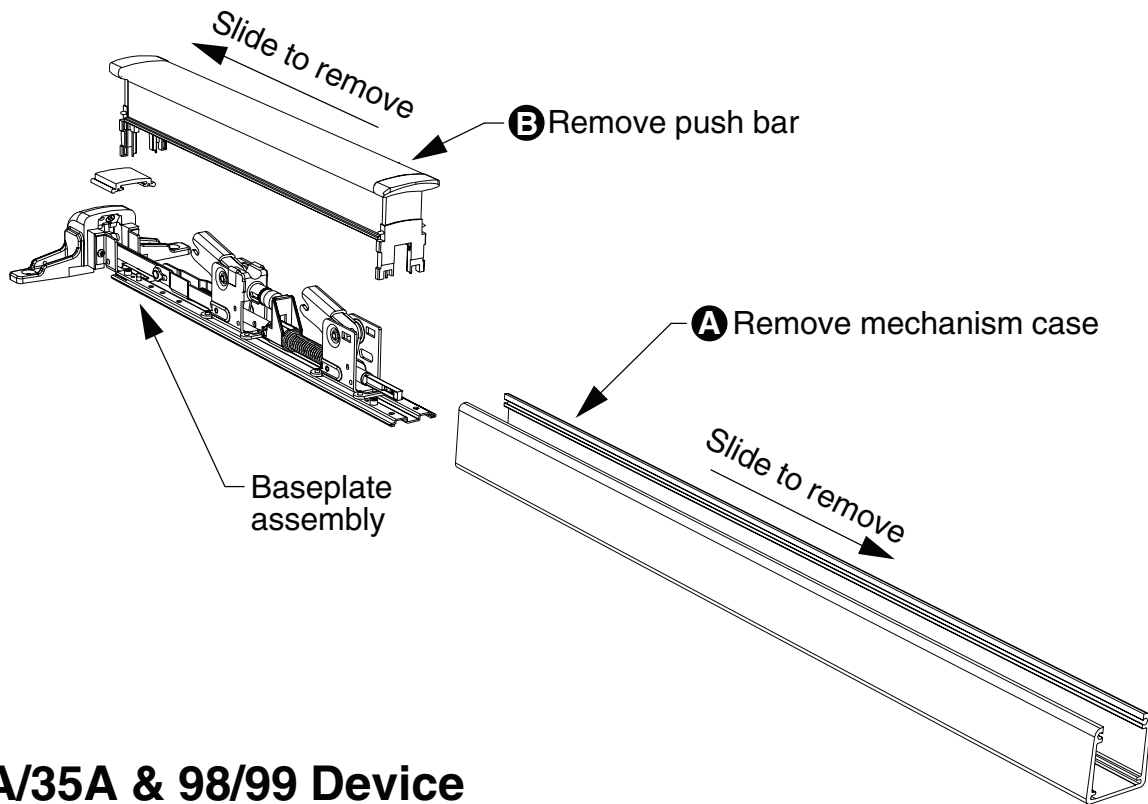

33A/35A & 98/99 Device

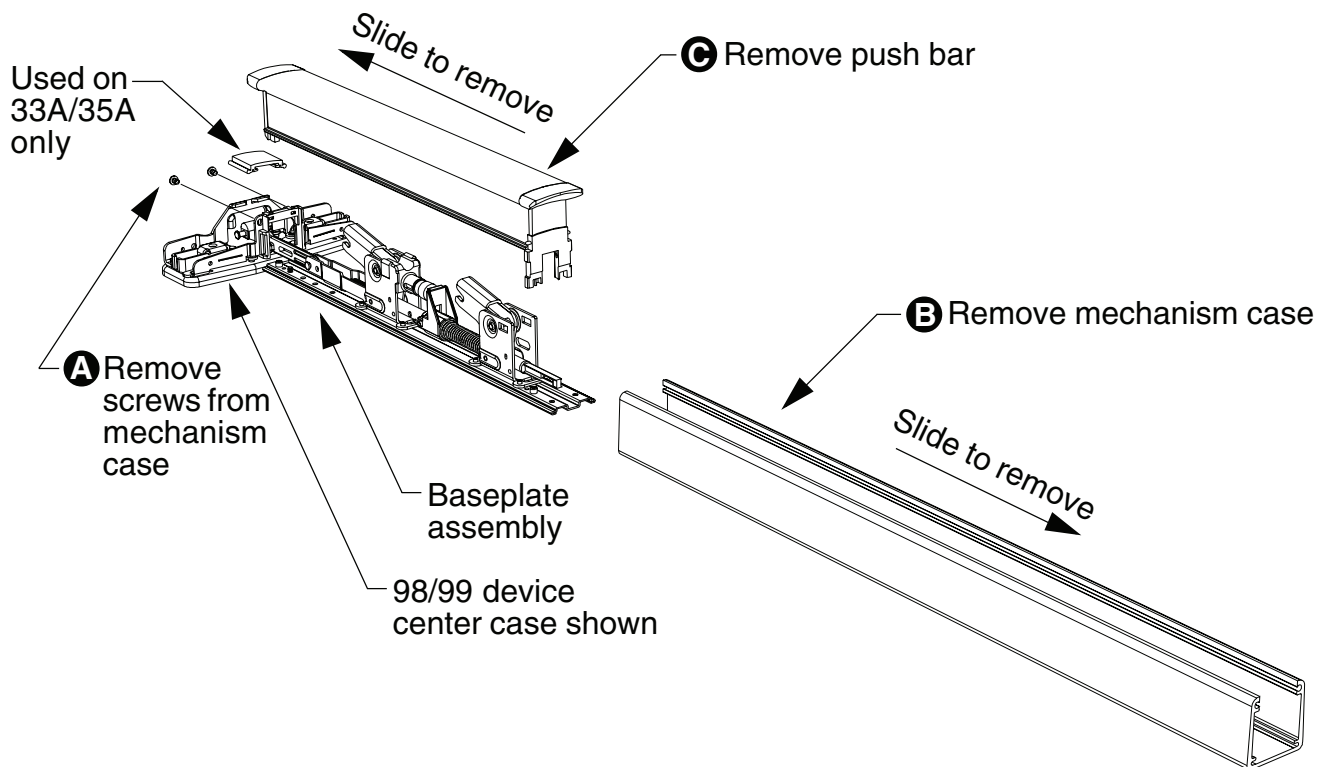

3 Remove main link retaining ring and pin.

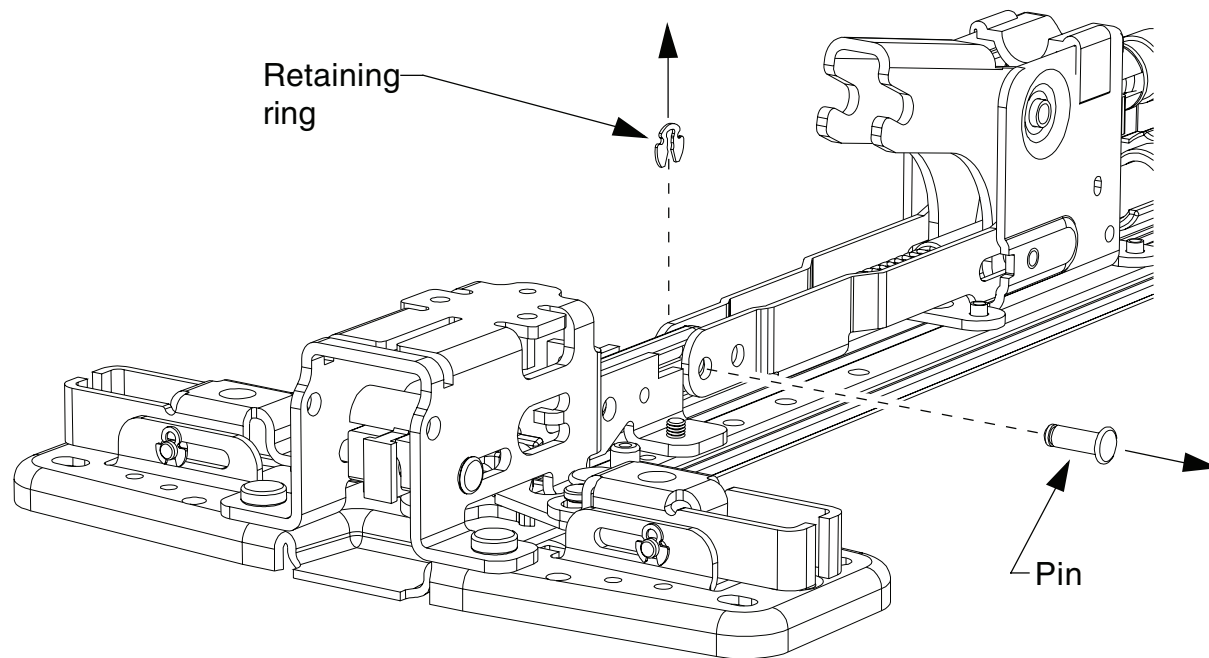

4 Remove screws connecting center case to baseplate.

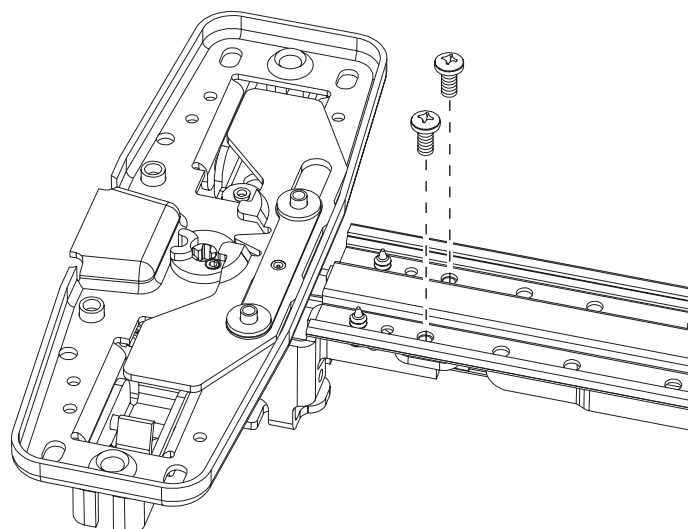

5 Install center case to new EL baseplate.

Warning: Make sure retaining ring is secure in the pin groove. If retaining ring is not secure it could result in an exit device that will not allow exit. This is a serious safety issue.

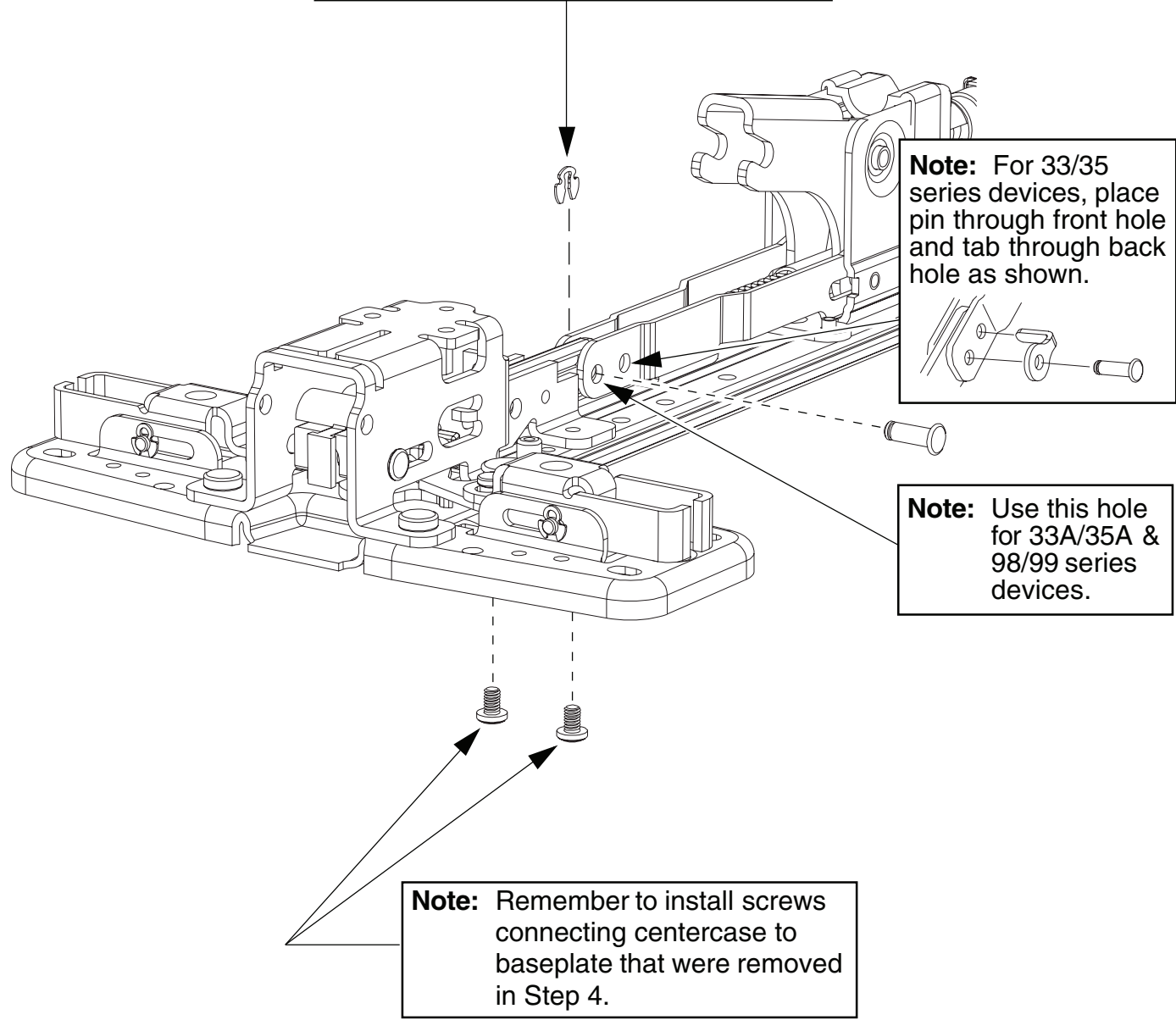

6 Reassemble device.

33/35 Device

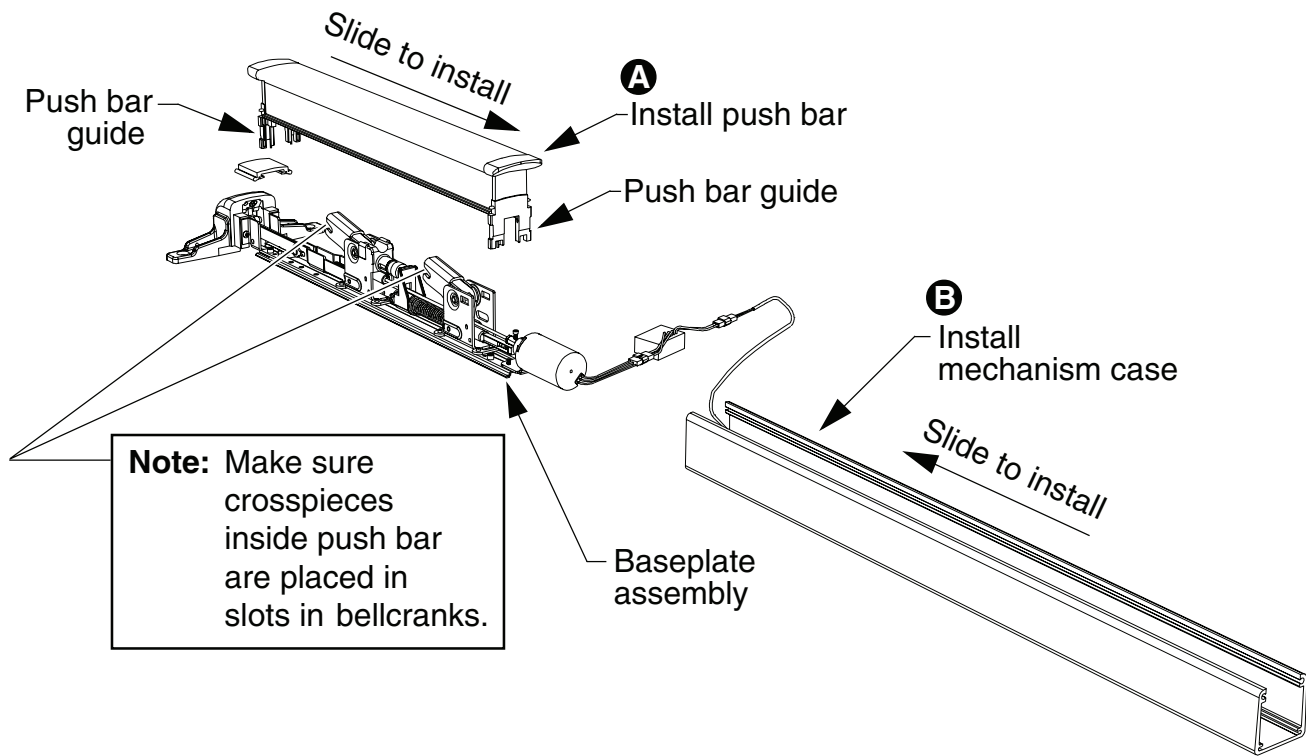

33A/35A & 98/99 Device

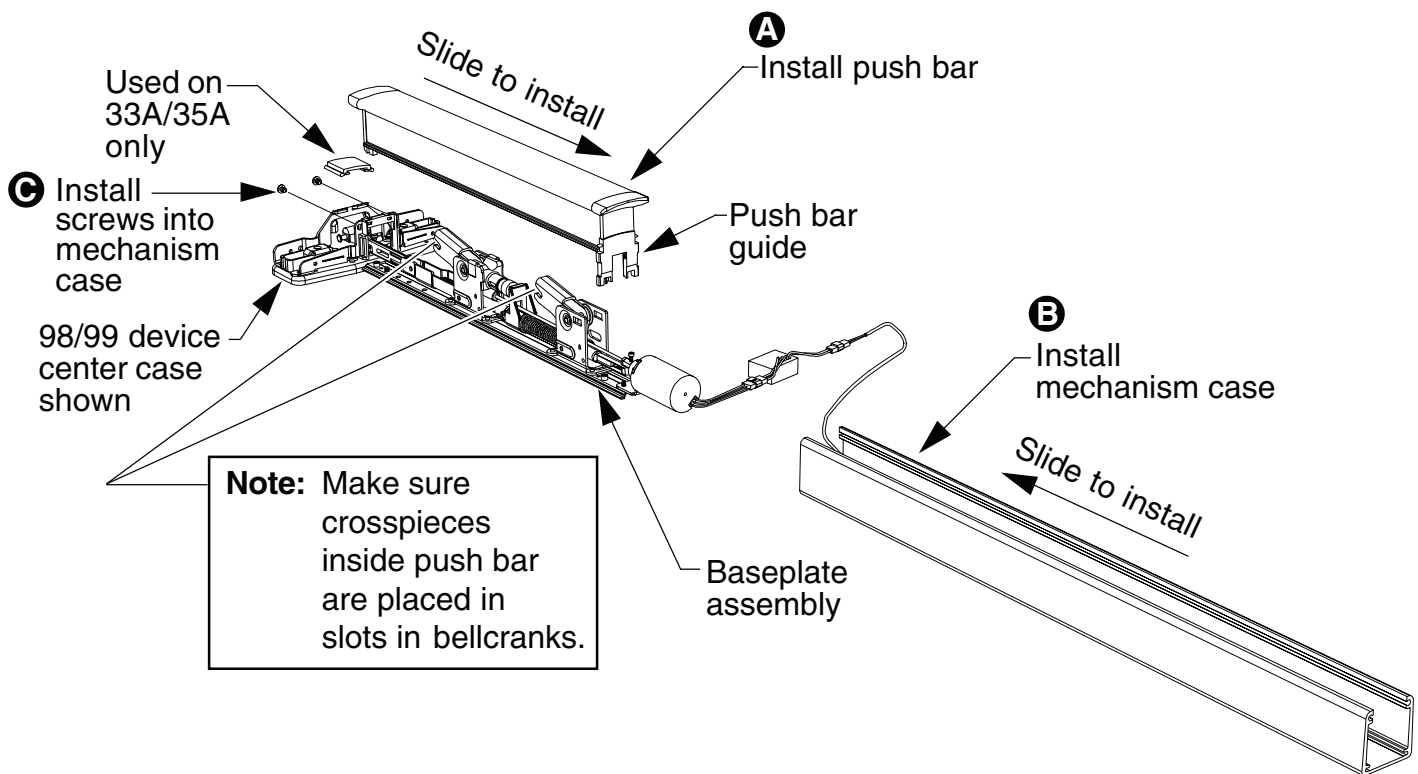

7 Drill solenoid cable hole and install device to door.

- A. Drill 5/8" diameter hole in door centered between end cap bracket mounting holes.
- B. Deburr hole.
- C. Reattach device and trim to door.

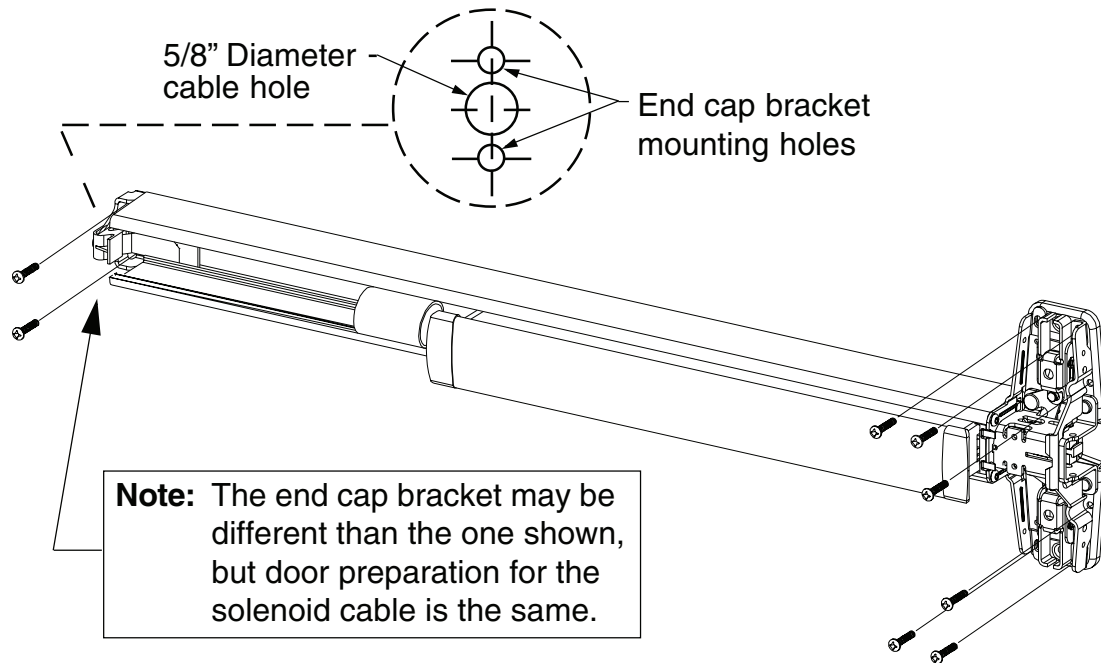

8 Route cable through hole in door.

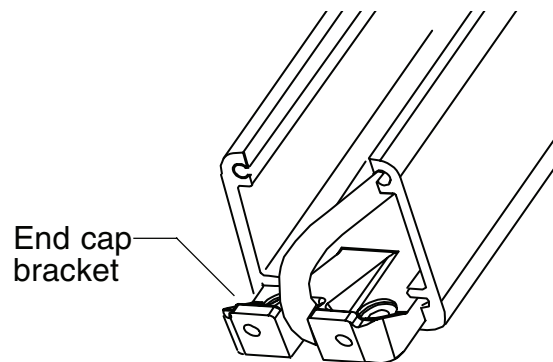

9 Install cover plate and end cap.

- A. If cover plate has a dogging key hole, rotate cover plate so hole is near end cap for standard EL device and near pushbar for HD-EL device.
- B. Install anti-rattle spring.
- C. Install cover plate.
- D. Install end cap.

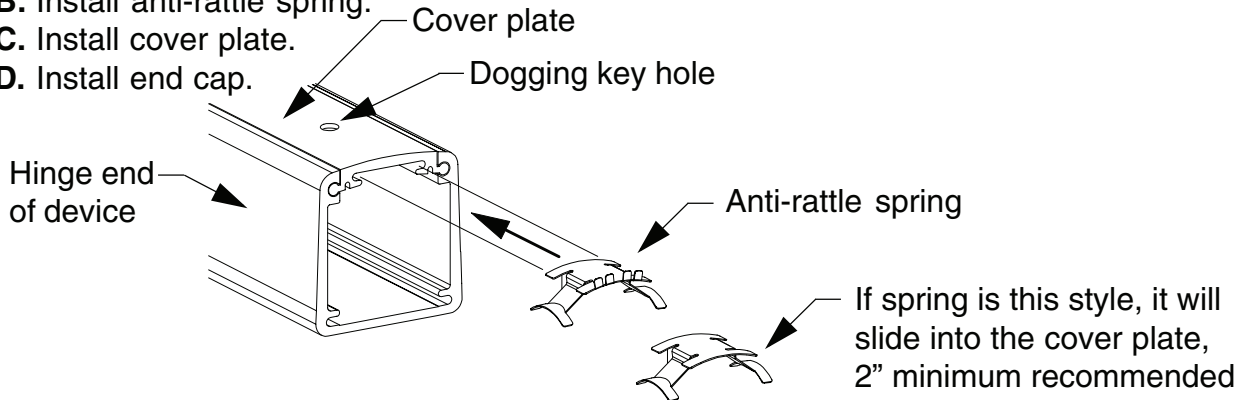

10 For vertical devices, reattach rods.

Reattach rods in reverse of when they were detached on pages 3 and 4.

11 Adjust rods as needed on vertical devices (find correct device on page 10 or 11).

9827/9927 Device or 3327A/3527A Device

Adjust top and bottom rod (screw rod into or out of latch) until adjusted as shown.

Note: On bottom latch, make sure latch bolt clears floor when door is swung open.

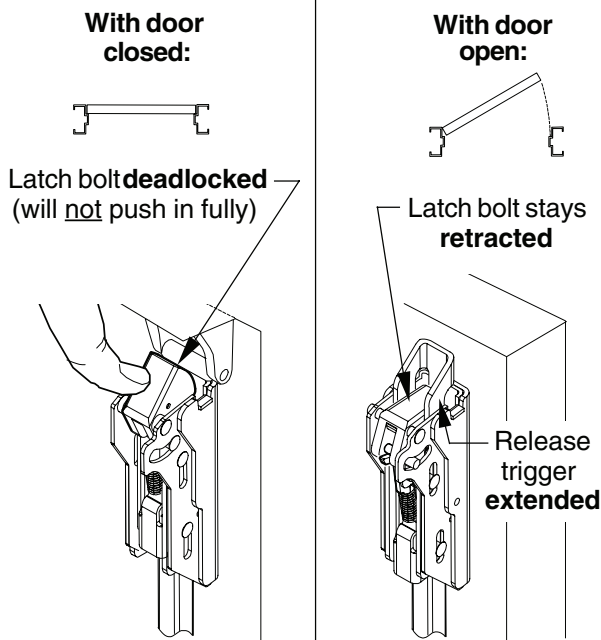

3327/3527 Device

Adjust top and bottom rod (screw rod into or out of center case rod connector) until adjusted as shown.

Note: On bottom latch, make sure latch bolt clears floor when door is swung open.

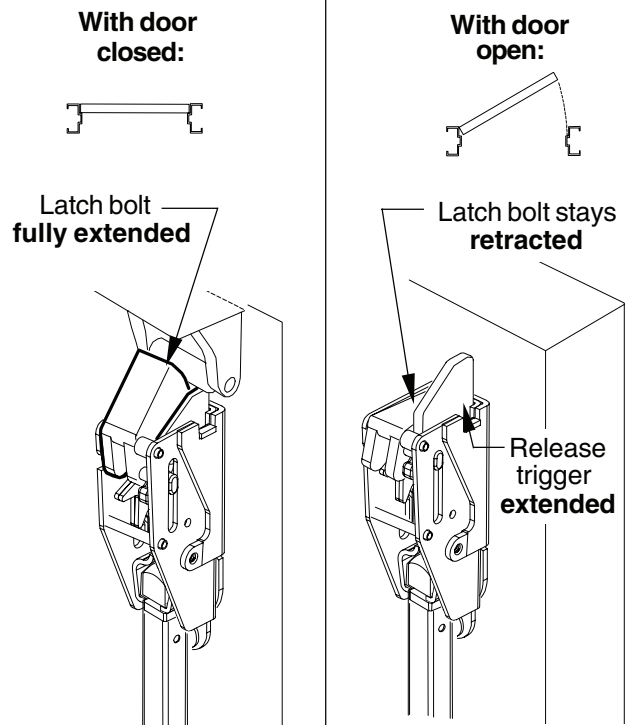

9847/9947 Device or 3347A/3547A Device

- A. Open door and release top latch bolt as shown (Figure 11-1).

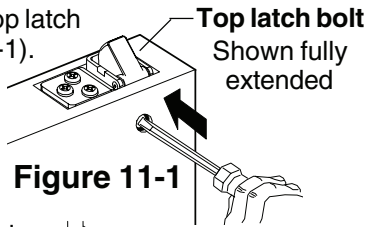

- B. Loosen bottom locking screw (Figure 11-2).

- C. Disconnect bottom vertical rod by removing bottom adjusting screw.

- D. Loosen top locking screw.

- E. Rotate top adjusting screw clockwise until top latch bolt is fully extended (Figure 11-1).

- F. Check top latch bolt for deadlocking (latch bolt should not push in fully).

- G. Turn top locking screw in. Do not over-tighten

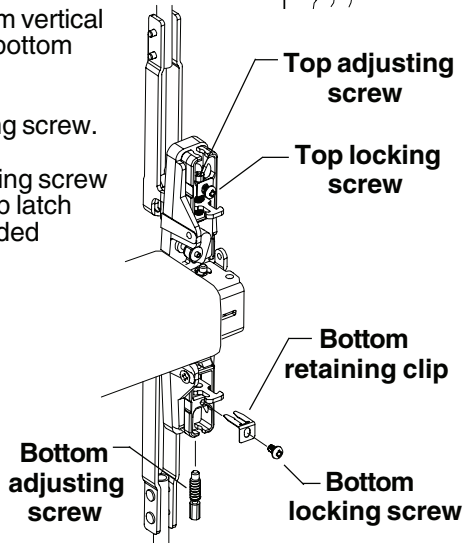

Figure 11-2

- H. Depress pushbar and release. (flush with latch case)

- I. Make sure top latch bolt stays retracted as shown.

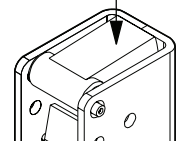

Figure 11-3

- J. Install bottom adjusting screw, retaining clip, and locking screw (Figure 11-2).

- K. With top latch bolt still retracted, adjust bottom rod so latch bolt clears floor and bottom strike.

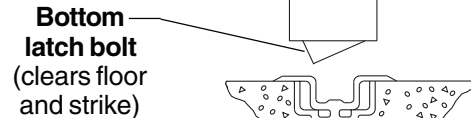

Figure 11-4

- L. Turn bottom locking screw in. Do not over-tighten.

- M. Close door and push up on bottom latch bolt to verify it is deadlocked (will not push in fully).

- N. Check device operation by opening and closing door several times from the outside.

Redo adjustment procedure if :

- Top latch bolt is not held retracted
- Bottom latch bolt does not clear floor and bottom strike

3347/3547 Device

- A. Loosen top and bottom adjusting screws.

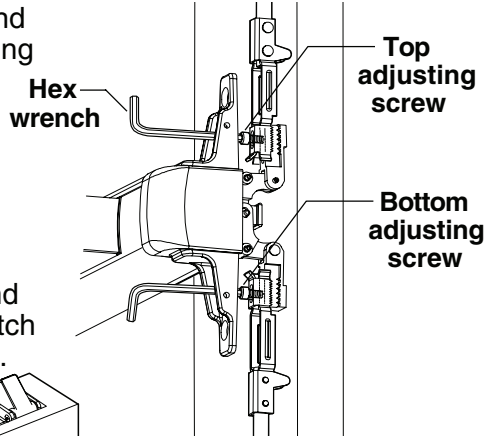

- B. Open door and release top latch bolt as shown.

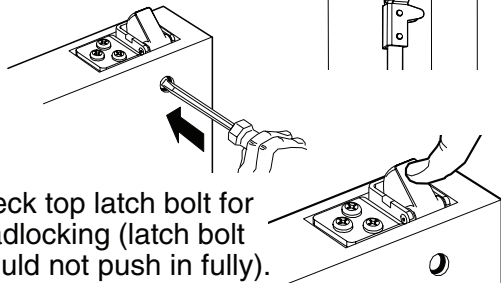

- C. Check top latch bolt for deadlocking (latch bolt should not push in fully).

- D. With top latch bolt still fully extended and pushbar in full up position (not depressed), tighten top adjusting screw.

- E. Depress pushbar and release.

Latch bolt retracted
(flush with latch case)

- F. Make sure top latch bolt stays retracted as shown.

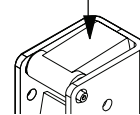

- G. With top latch bolt still retracted, push bottom latch bolt up until it clears floor and bottom strike and hold it there.

Bottom latch bolt
(clears floor and strike)

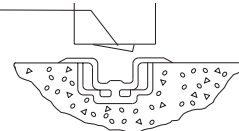

- H. Tighten bottom adjusting screw.

- I. Close door and push up on bottom latch bolt to verify it is deadlocked (will not push in fully).

- J. Check device operation by opening and closing door several times from the outside.

Redo adjustment procedure if :

- Top latch bolt is not held retracted
- Bottom latch bolt does not clear floor and bottom strike

12 Complete wiring.

12 AWG required for distances up to 200'
14 AWG permitted for distances 0-100'

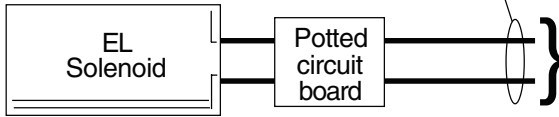

ELECTRICAL SPECIFICATIONS

Voltage: 24 VDC
Current: 16 A inrush (0.3 sec.)
0.25 A holding

NOTE

When power is applied to the **potted circuit board**, the solenoid receives a momentary signal to retract and a separate signal to hold as long as power is applied. When attempting to retract solenoid again, power must be removed from the circuit and reapplied.

Troubleshooting solenoid operation

If the solenoid fails to retract the latch bolt when power is applied, recheck wiring for proper connections.

If solenoid retracts latch bolt momentarily but will not remain in energized position:

1. Check wiring for proper connections, gauge, and distances.
2. Check for latch bolt binding caused by improper strike installation, warped door, etc. Also check adjustment of vertical rods.

EL WIRING

Solenoid draws 16 A inrush current from PS914. Solenoid must be wired to a 900-2RS logic board:

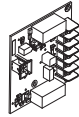

If 900-2RS logic board, refer to instructions 44487056.

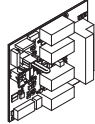

If 900-4RL logic board, refer to instructions 44487080.

Solenoid

Potted Circuit Board
Install after device has been mounted on door

Do not cut device with potted circuit board installed

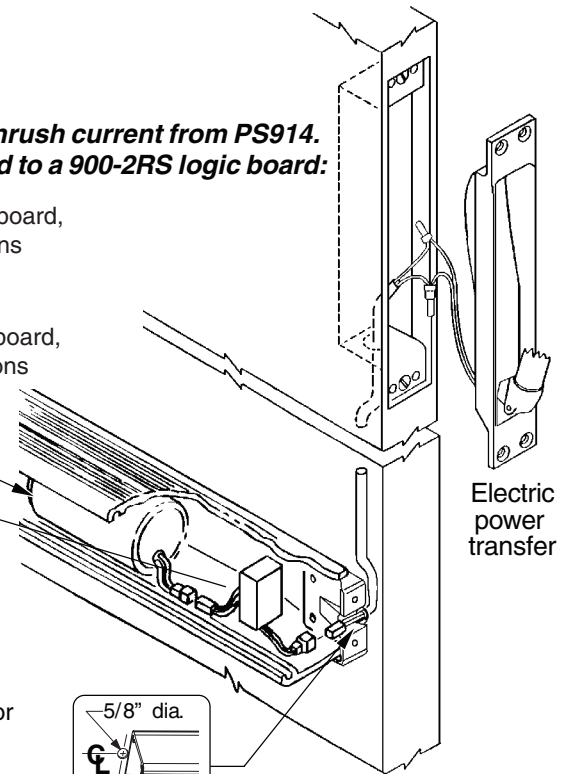

Drill 5/8" dia. wire access hole thru device side of door.

13 Adjust EL device for proper function.

A. Check for proper function:

1. Make sure device is not dogged.
2. Depress pushbar and make sure latch bolt(s) retracts and extends fully (see Figure 13-1).
3. Electrically energize solenoid and hold.
4. Check latch bolt(s) for full retraction (must clear strike, see Figure 13-1).
5. Release solenoid and check latch bolt extension (see Figure 13-1).
6. Continue to Section B if device does not function electrically.

B. Determine if dogging rod adjustment is too long or short:

1. The dogging rod adjustment is too **long** if latch bolt does not retract and clear strike (see Section C for adjustment).
2. The dogging rod adjustment is too **short** if latch bolt does not fully extend **or** latch bolt fully retracts but solenoid releases while energized (see Section D for adjustment).

C. Adjust solenoid if dogging rod is too **long** (see Figure 13-2):

1. Remove end cap ① and dogging cover ②.
2. Loosen cap screw ③.
3. Hold plunger ⑤ depressed in solenoid housing ⑥.
Note: Push hard against plunger ⑤ to overcome an internal spring in solenoid housing ⑥.
4. Turn threaded bushing ④ in to shorten dogging rod ⑦ so latch bolt fully retracts.
5. Tighten cap screw ③.
Note: Cap screw ③ must be tightened against flat on threaded bushing ④. Apply a few drops of Loc-Tite 222 to threads of cap screw ③.
6. Replace dogging cover ② and end cap ①.
7. Return to Section A to check for proper function.

Note: Rim device shown, see pages 10 and 11 for verticals

Latch bolt extended 3/4"
Latch bolt retracted Flush within 1/16"



Figure 13-1

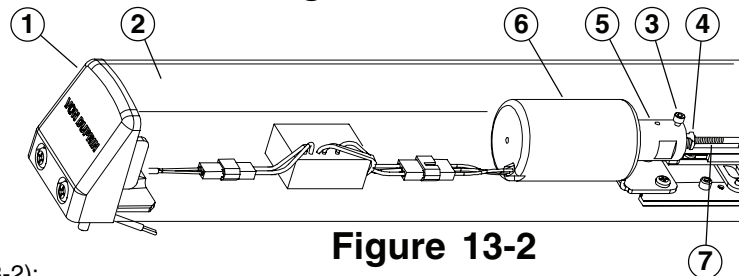

Figure 13-2

D. Solenoid adjustment if dogging rod adjustment is too **short** (see Figure 13-2):

1. Remove end cap ① and dogging cover ②.
2. Loosen cap screw ③.
3. Hold plunger ⑤ depressed in solenoid housing ⑥.
4. Turn threaded bushing ④ out to lengthen dogging rod ⑦ so plunger ⑤ just bottoms in solenoid housing ⑥ and latch bolt is fully retracted.
Note: Push hard against plunger ⑤ to overcome an internal spring in solenoid housing ⑥.
5. Tighten cap screw ③.
Note: Cap screw ③ must be tightened against flat on threaded bushing ④. Apply a few drops of Loc-Tite 222 to threads of cap screw ③.
6. Replace dogging cover ② and end cap ①.
7. Return to Section A to check for proper function.