



911403-00

33/3527A

VON DUPRIN®

Surface Vertical Rod Exit Device

Installation Instructions

Devices covered by these instructions:

- 33/3527A Surface Vertical Rod Exit Device
- 33/3527A-F (Fire) Surface Vertical Rod Exit Device
- CD33/3527A Surface Vertical Rod Exit Device
- EL33/3527A Surface Vertical Rod Exit Device
- SS33/3527A Surface Vertical Rod Exit Device

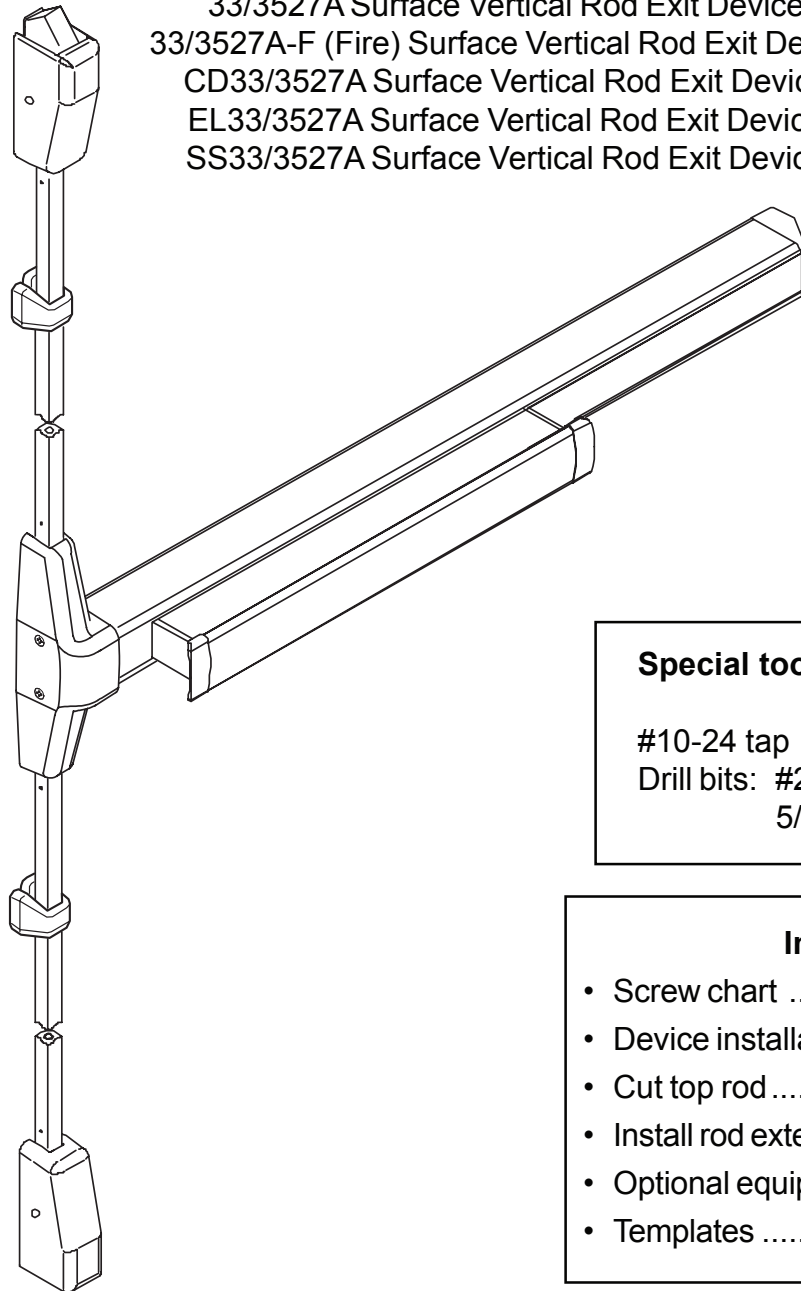

Special tools needed:

- #10-24 tap
- Drill bits: #25, 1/8", 1/4",
5/16", 13/32"

Index:

- Screw chart 2
- Device installation 3-6
- Cut top rod 7
- Install rod extension 7
- Optional equipment 8
- Templates 9-14

Please give these instructions to building owner after device is installed

SCREW CHART

A

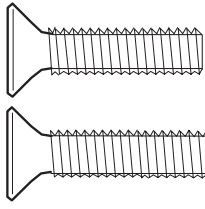
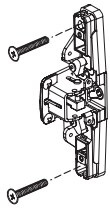

1/4-20 x 1"

Trim mount or sex bolts:
(1-3/4" door)

1/4-20 x 1-1/2"

(2-1/4" door)

B

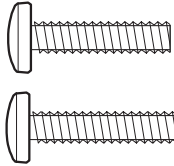
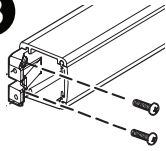

#10-24 X 3/4"

Surface mount or
Sex bolts (1-3/4" door)

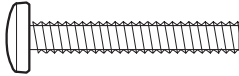

#10-24 X 1-1/8"

Sex bolts (2-1/4" door)

C



#10-16 X 3/8" Thread cutting

End cap

D

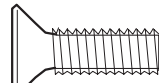
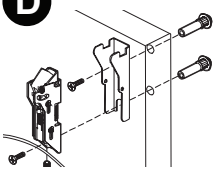

1/4-20 X 3/4"

1-3/4" door

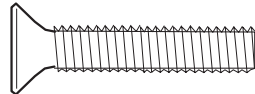

1/4-20 X 1-1/4"

2-1/4" door

E

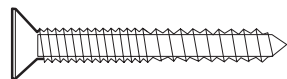
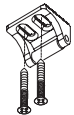

#10-12 x 10-24 x 1-1/4" combination

Metal or wood frame

F

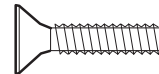
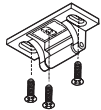

#10-24 X 3/4"

Metal frame

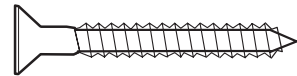

#10-24 X 1-1/4" wood screw

Wood frame

G

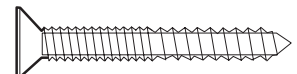
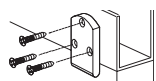

#10-12 x 10-24 x 1-1/4" combination

Metal or wood frame

H

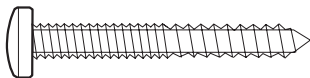

#10-12 x 10-24 x 1-1/4" combination

Variable floor surfaces

I

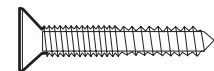
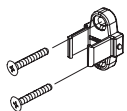

#8-16 x 8-32 x 1" combination

Metal or wood door

J

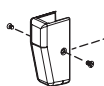

#8-32 X 1/4"

Latch covers

K

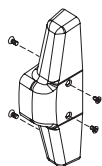

#8-18 x 3/8" thread cutting

Center case cover

1

Figure backset and draw device center lines (☉) on door as shown.

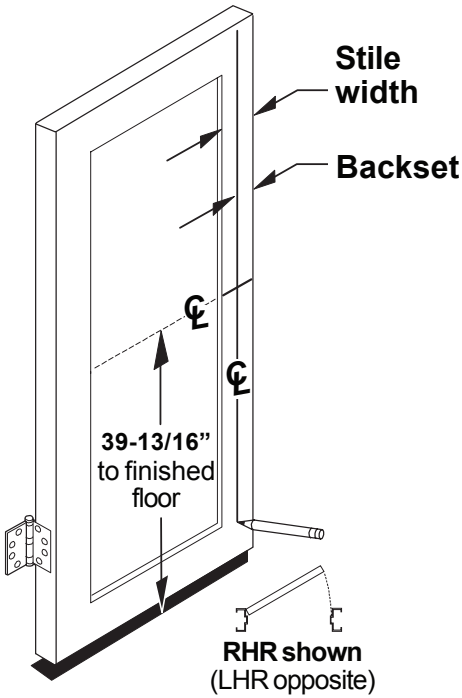

Backset is measured from outer edge of door as shown. Minimum stile is less glass stop (rectangular glass stop is recommended for stiles less than 2-1/8")

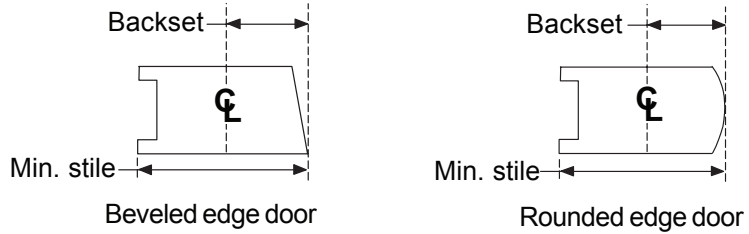

Backset	Min. stile	Application
1-3/16"	2" - 2-3/4"	Two vertical rod devices
1-1/2"	2-3/4" - 3-3/4"	
1-7/8"	3-3/4" - 5"	
2-1/2"	5" to flush	
1-11/32"	2" - 2-3/4"	Single door
1-1/2"	2-3/4" - 3-3/4"	
1-7/8"	3-3/4" - 5"	
2-1/2"	5" to flush	
2-7/32"	3" min.	Vertical rod and rim device

Note: For 299/299F top strike use minimum backsets shown below.

Double doors: 1-3/8" min. backset
2-3/16" min. stile

Single door: 1-7/8" min. backset
2-11/16" min. stile

2

Tape templates to door and prepare door and frame per templates.

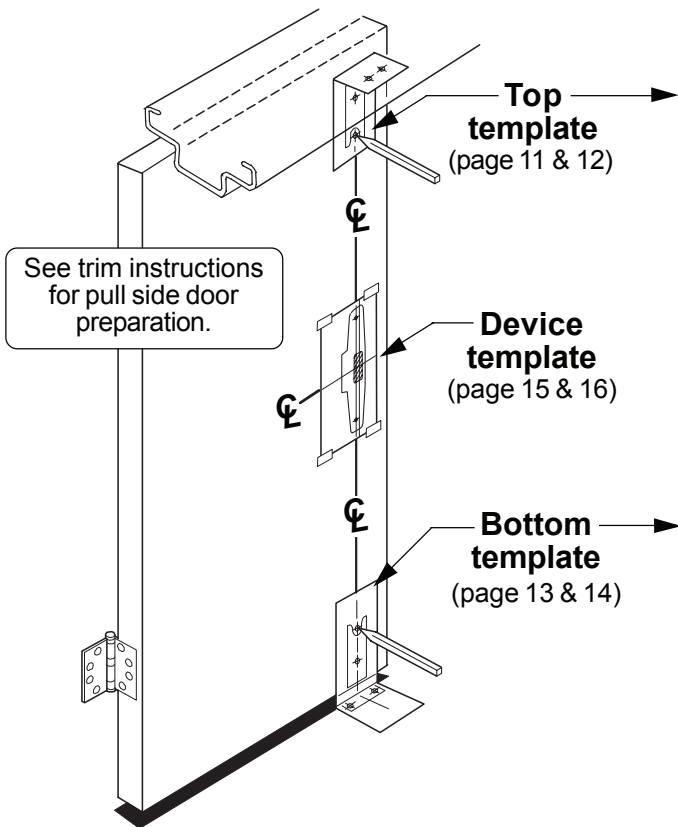

260U strike

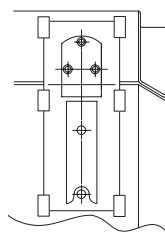

266 strike

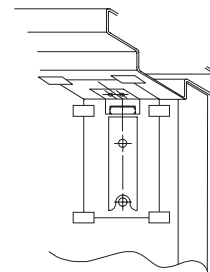

***299/299F strike**

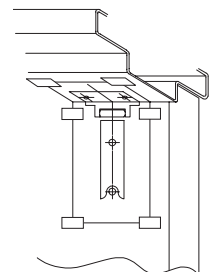

248L-4 strike

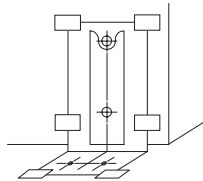

304L strike

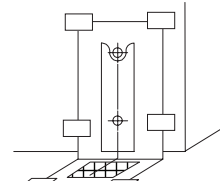

Latch track

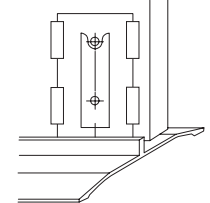

*For 299/299F top strike use minimum backsets shown below.

Double doors: 1-3/8" min. backset, 2-3/16" min. stile

Single door: 1-7/8" min. backset, 2-11/16" min. stile

3

Measure to determine length to cut device.

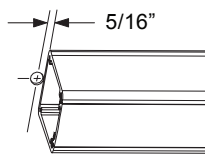
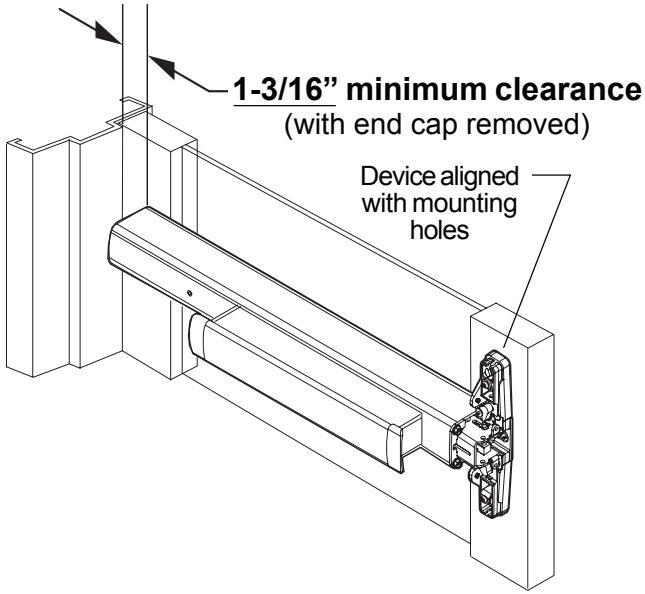

Note

If 5/8" diameter wire access hole has been predrilled in door, cut device 5/16" from center of hole.

4

Cut device to length.

Prepare device for cutting

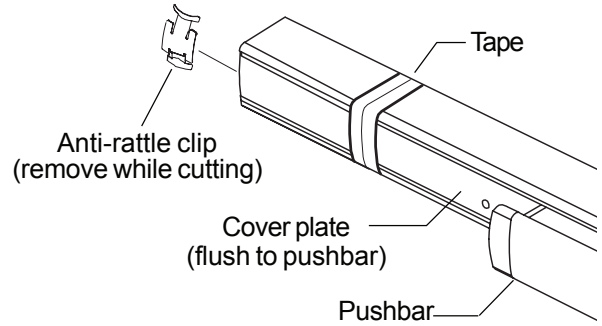

Cut device square

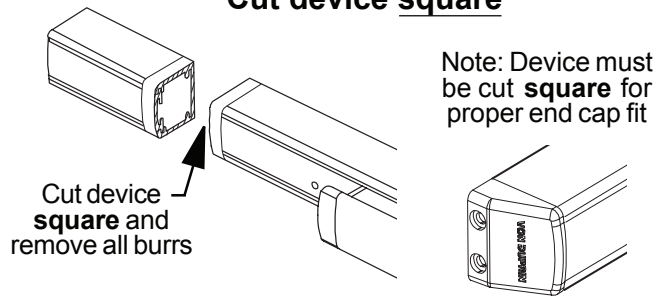

5

Install tailpiece guide and trim (or sex bolts) and secure device center case to door.

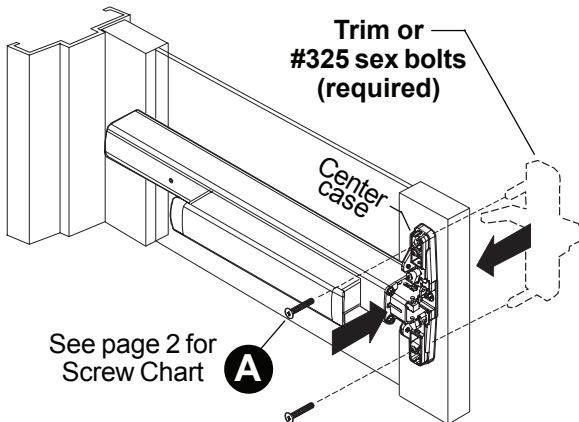
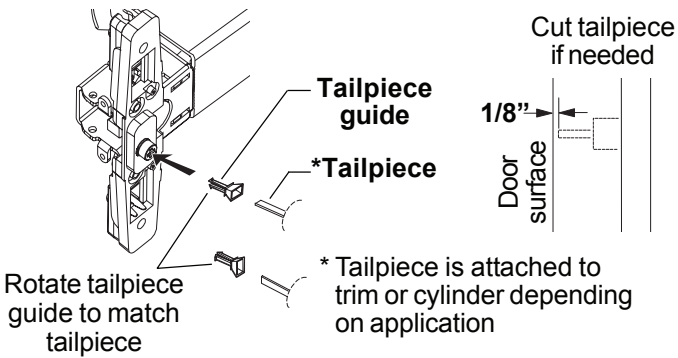

6

Install hinge stile mounting bracket.

Mark and prepare 2 mounting holes

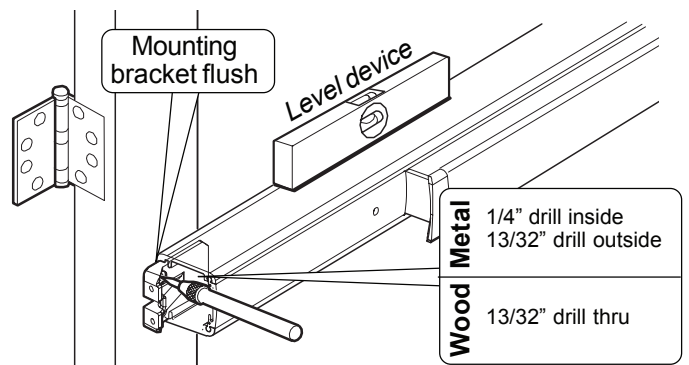

Secure mounting bracket

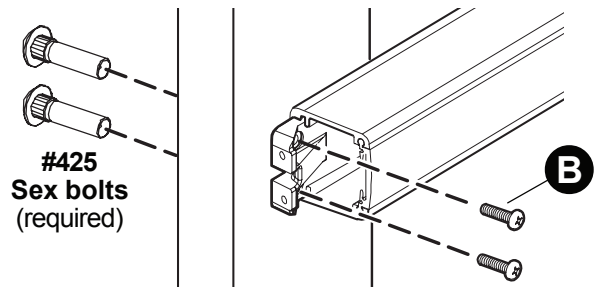

7

Install top latch and rod.

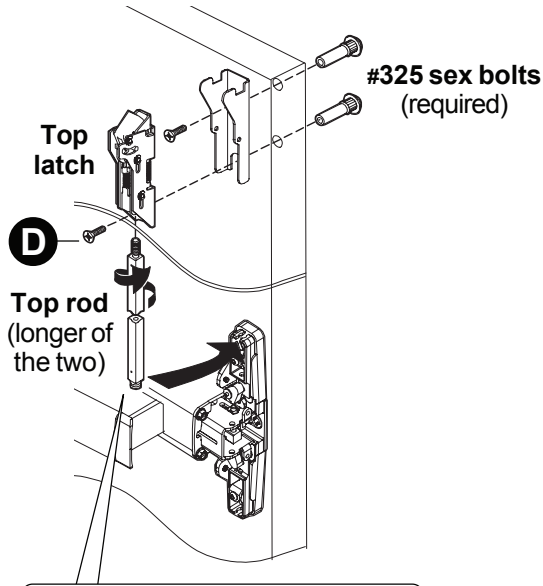

If top rod is too long, see "Cut top rod" on page 7

If top rod is too short, see "Install rod extension" on page 7

8

Install top strike.

266 strike
For panic device application only

260U strike
For panic device application only

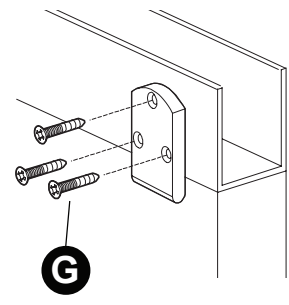
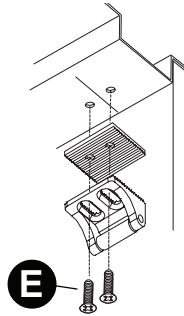

299/299F strike

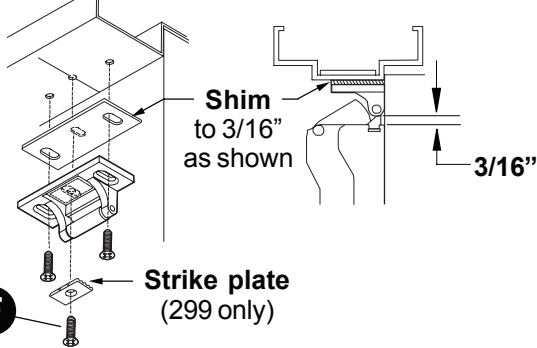

Shim to 3/16" as shown

Strike plate (299 only)

9

Adjust top rod until latch bolt acts as shown.

Adjust rod by threading rod into latch clockwise to shorten, or counterclockwise to lengthen.

With door closed:



With door open:

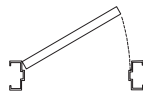

Latch bolt **deadlocked** (will not push in)

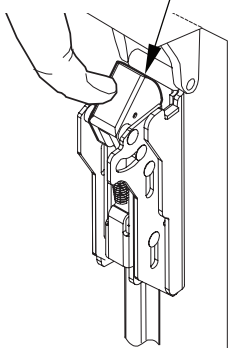

Latch bolt stays **retracted**

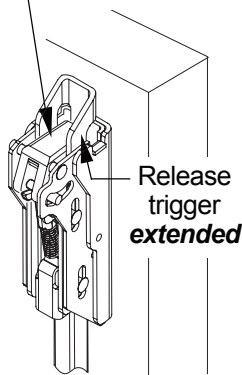

10

Install bottom strike, latch, and rod.

248L-4 strike

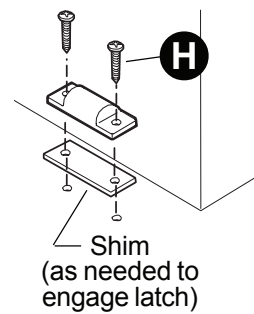

Use 248L-4 strike for panic device application only. Use 304L for fire doors

304L strike

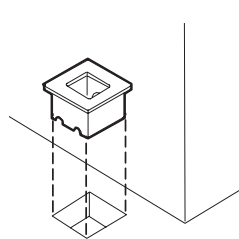

Grout strike into floor

11

Install bottom rod.

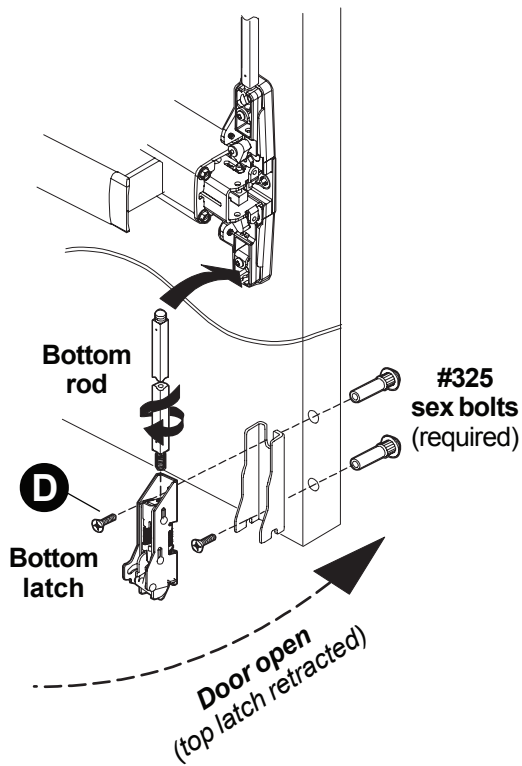

12

Adjust bottom rod with door open (top latch retracted).

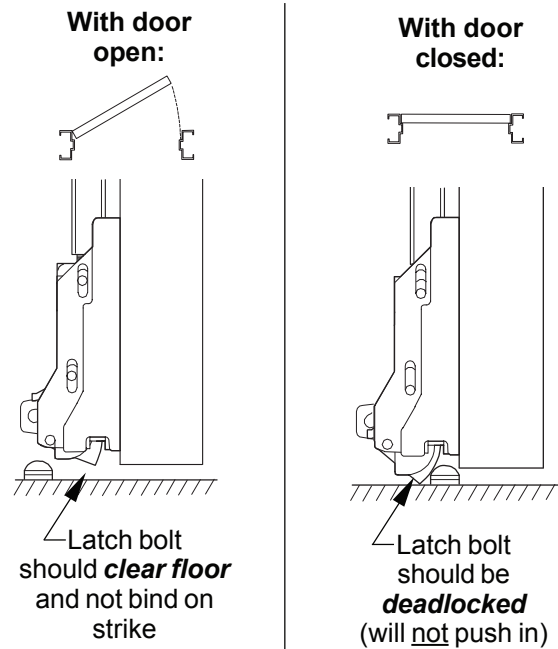

Open and close door a few times and check for deadlocking when door is closed

Readjust rods if needed

13

Install rod guides.

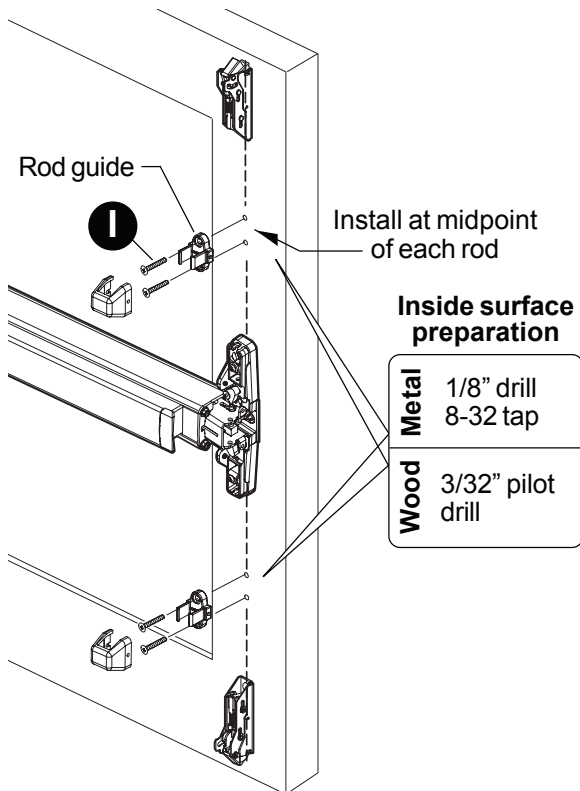

14

Install covers and end cap.

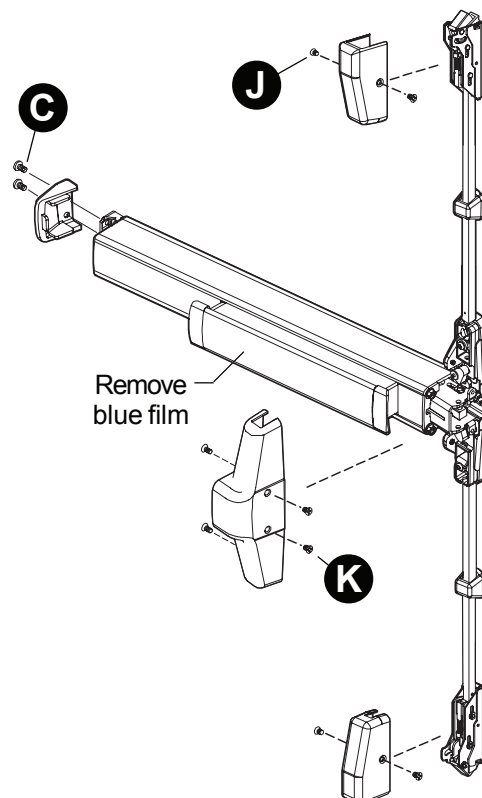

CUT TOP ROD

1. Measure amount to cut off rod as shown below.

Note: Rod cutting is required for doors shorter than 7'.

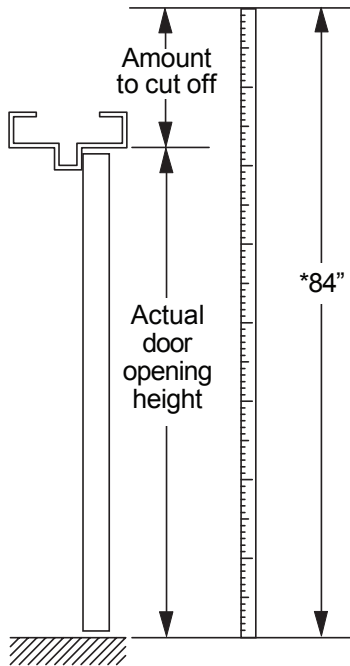

*Rods are factory sized for 7' (84") door. Measure actual door opening height and subtract that number from 84" to get amount to cut off top rod.

2. Cut rod.

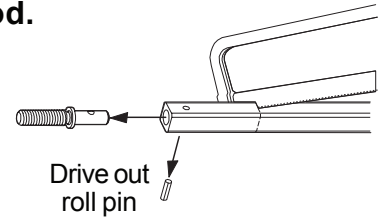

Drive out roll pin

3. Drill new hole.

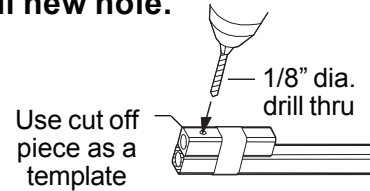

Use cut off piece as a template

1/8" dia. drill thru

4. Reinstall rod end and roll pin.

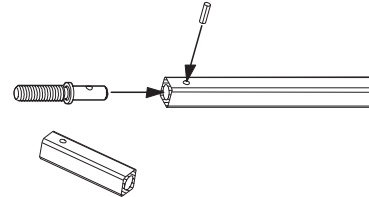

INSTALL ROD EXTENSION

1. Measure door opening to determine amount to cut off rod extension.

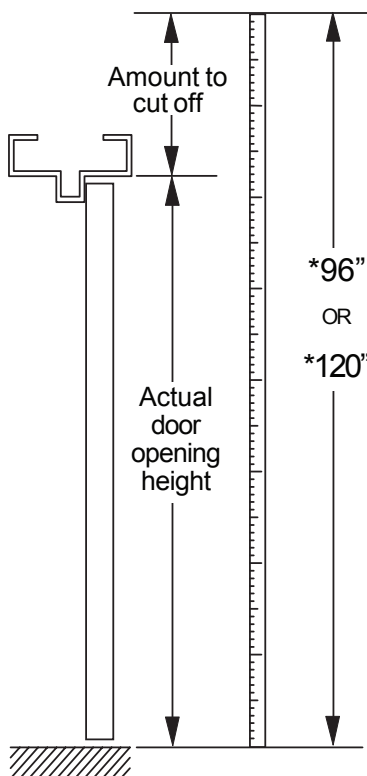

*Standard door heights:

With no extension	7' (84")
With 1' extension	8' (96")
With 3' extension	10' (120")

*Rods are factory sized for door heights shown above. Measure actual door opening height and subtract that number from 96" (for 1' extension) or 120" (for 3' extension) to get amount to cut off extension.

2. Cut rod extension.

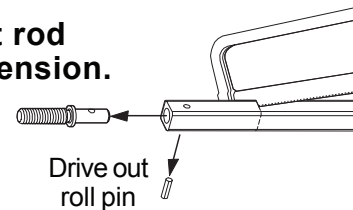

Drive out roll pin

3. Drill new hole.

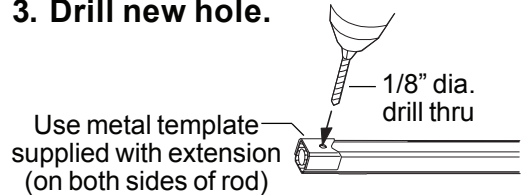

Use metal template supplied with extension (on both sides of rod)

1/8" dia. drill thru

4. Reinstall rod end and roll pin.

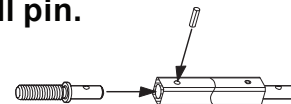

5. Connect top rod and rod extension.

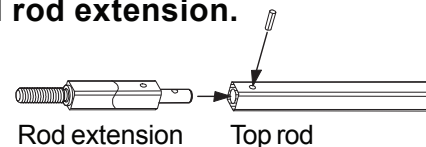

Rod extension

Top rod

OPTIONAL EQUIPMENT

CD (CYLINDER DOGGING)

1. Remove mortise cylinder cam and reinstall in reverse (Figure 1).
2. Insert key and rotate cam to install the cylinder to the cover plate (Figure 2).
3. Remove key to slide cover plate in position in the mechanism case.

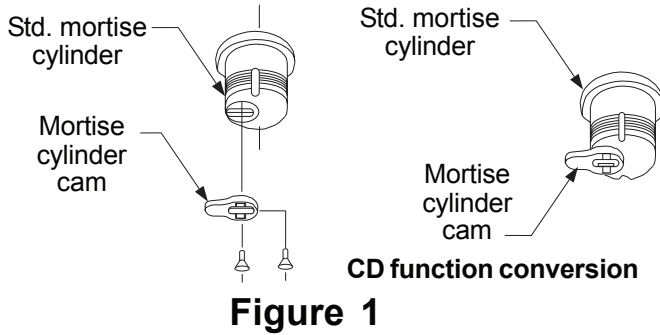

Dogging procedure

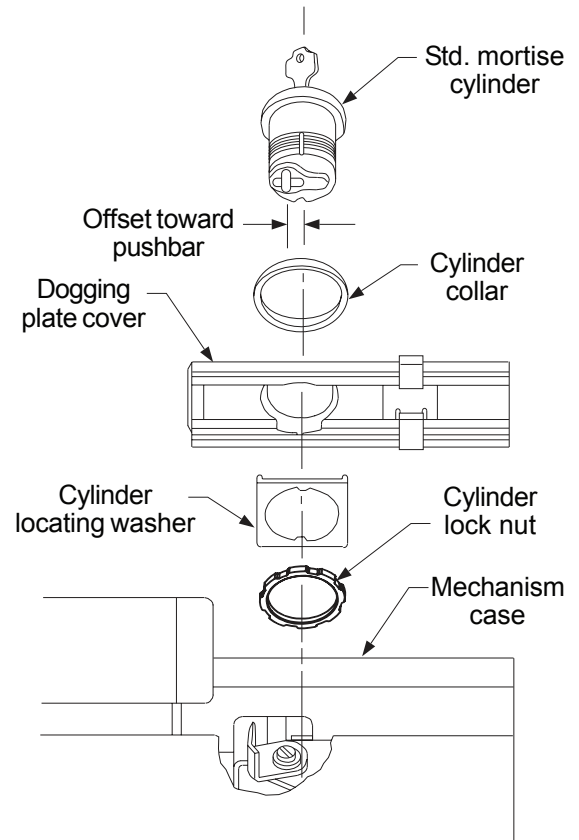
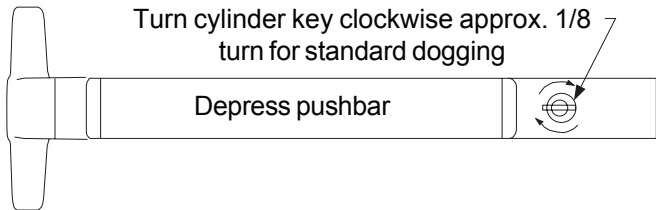

TOP LATCH AND 260U STRIKE

For panic device application only

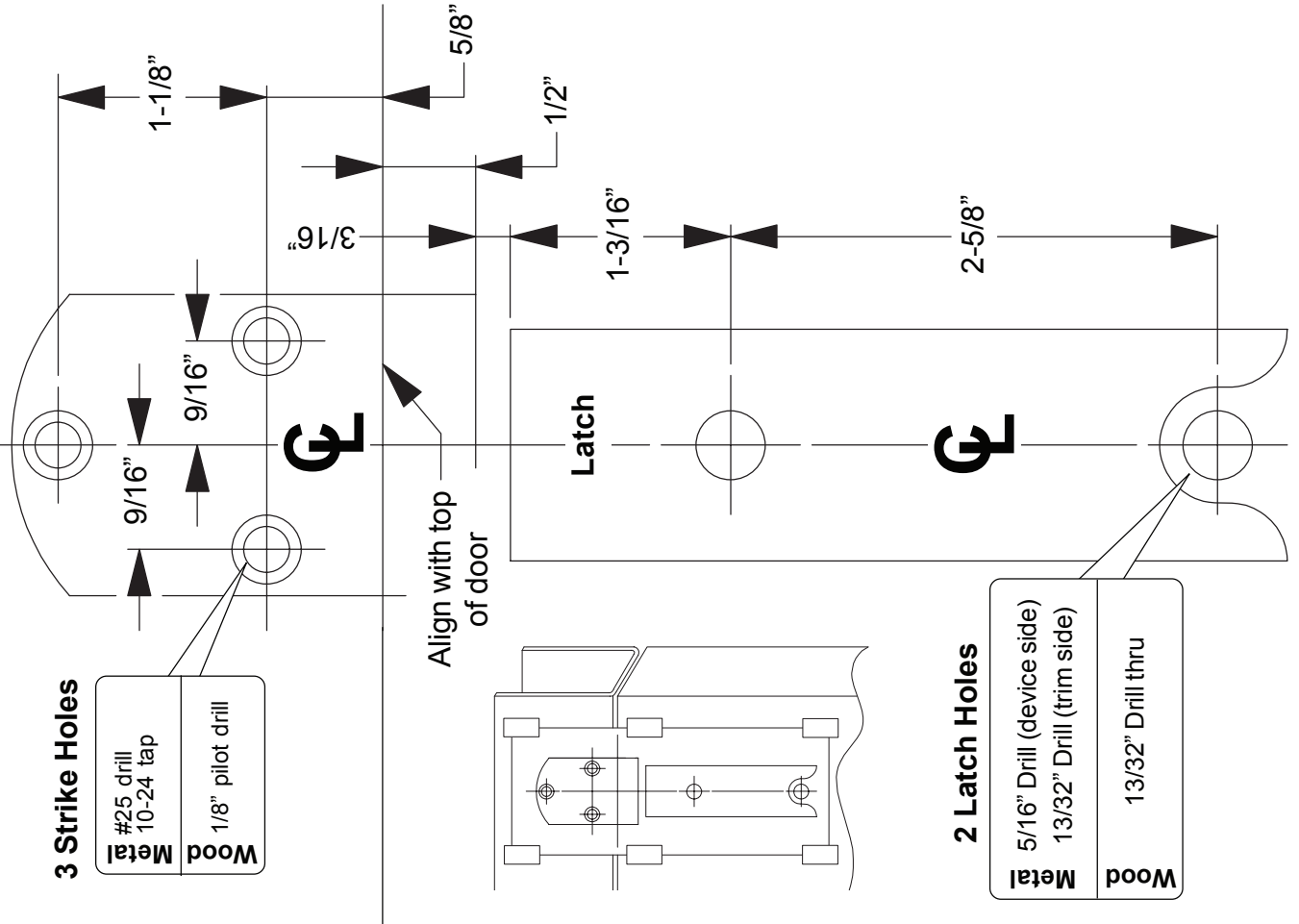

TOP LATCH & 266 STRIKE

For panic device application only

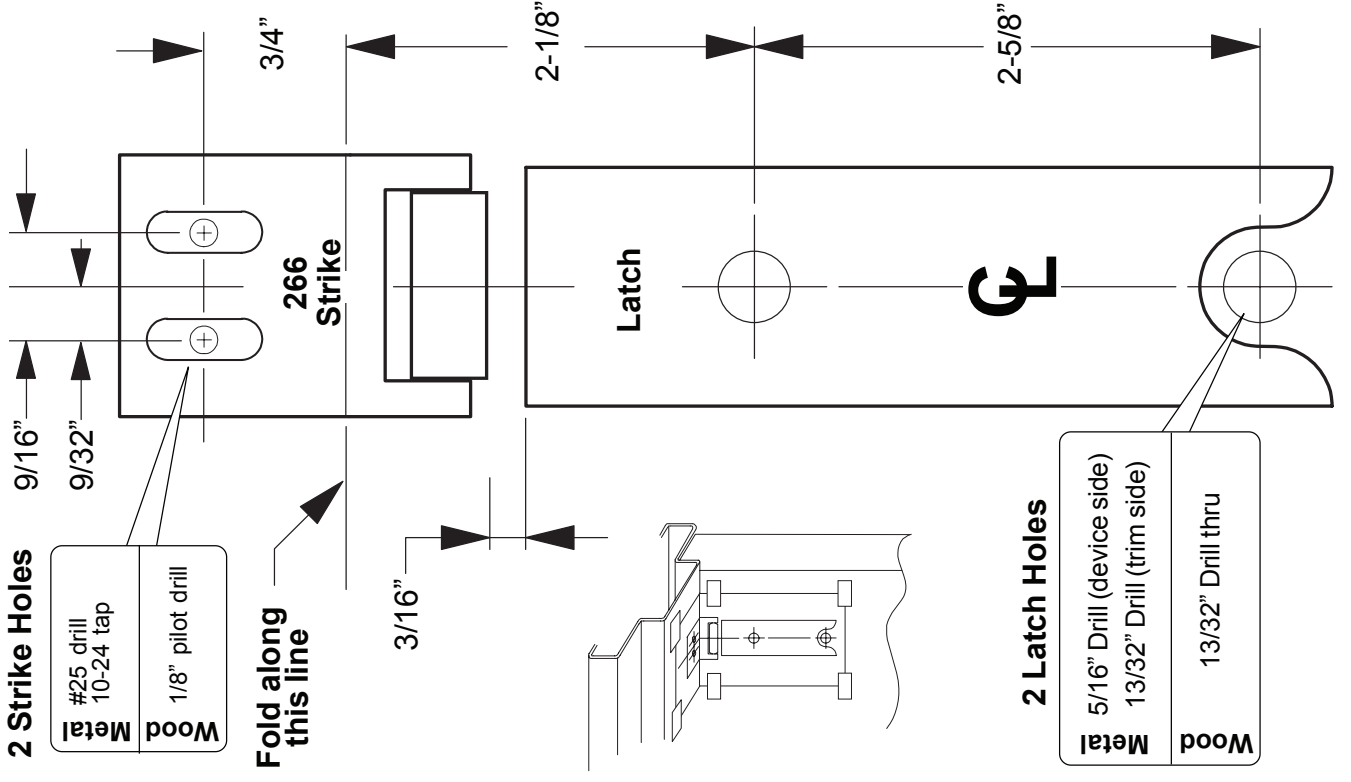

TOP TEMPLATE

TOP TEMPLATE - CONTINUED

Note: For 299/299F top strike use minimum backsets shown below.

Double doors: 1-3/8" min. backset, 2-3/16" min. stile

Single door: 1-7/8" min. backset, 2-11/16" min. stile

TOP LATCH & 299/299F/499F STRIKE

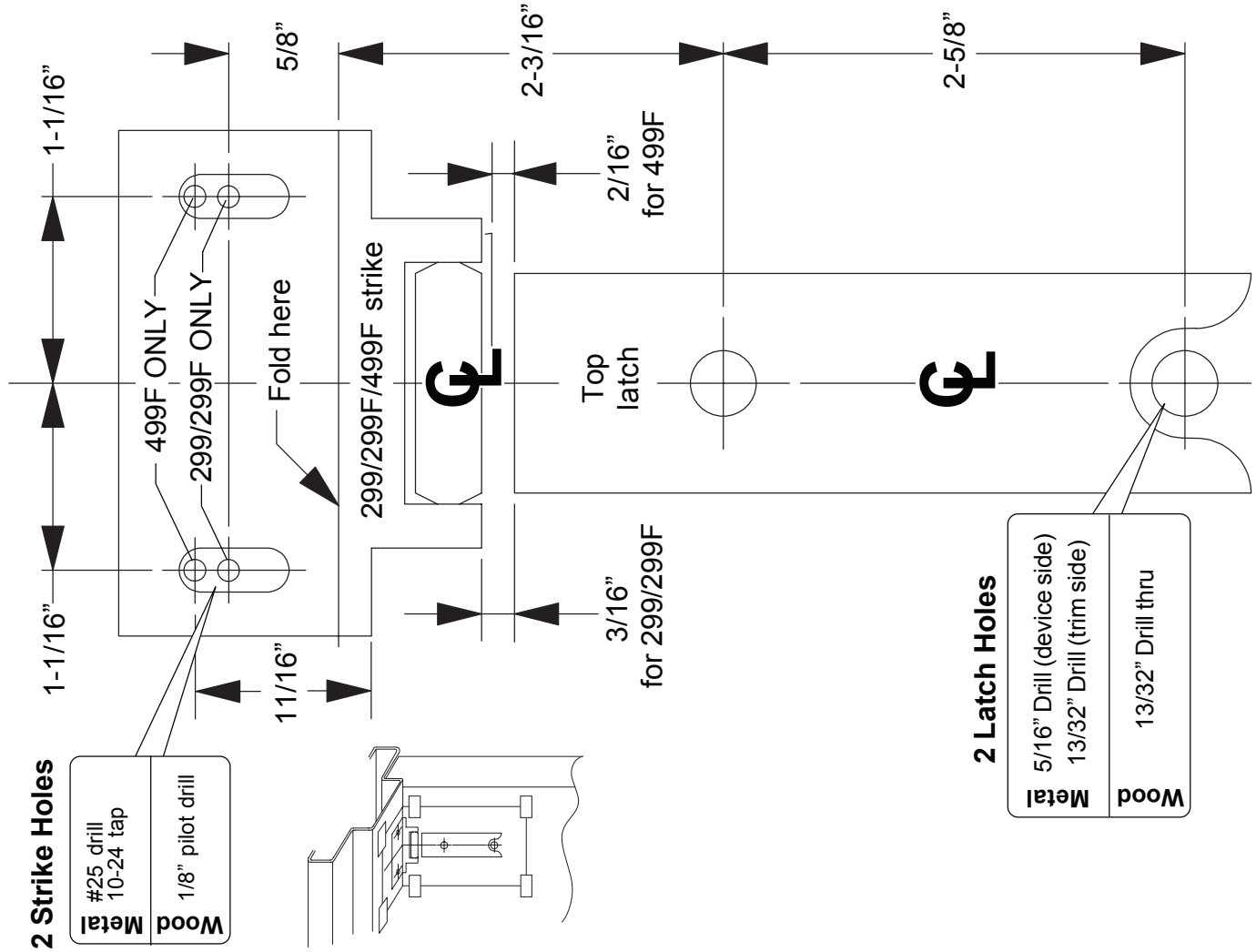

BOTTOM TEMPLATE

BOTTOM LATCH AND 248-L4 STRIKE

For panic device application only

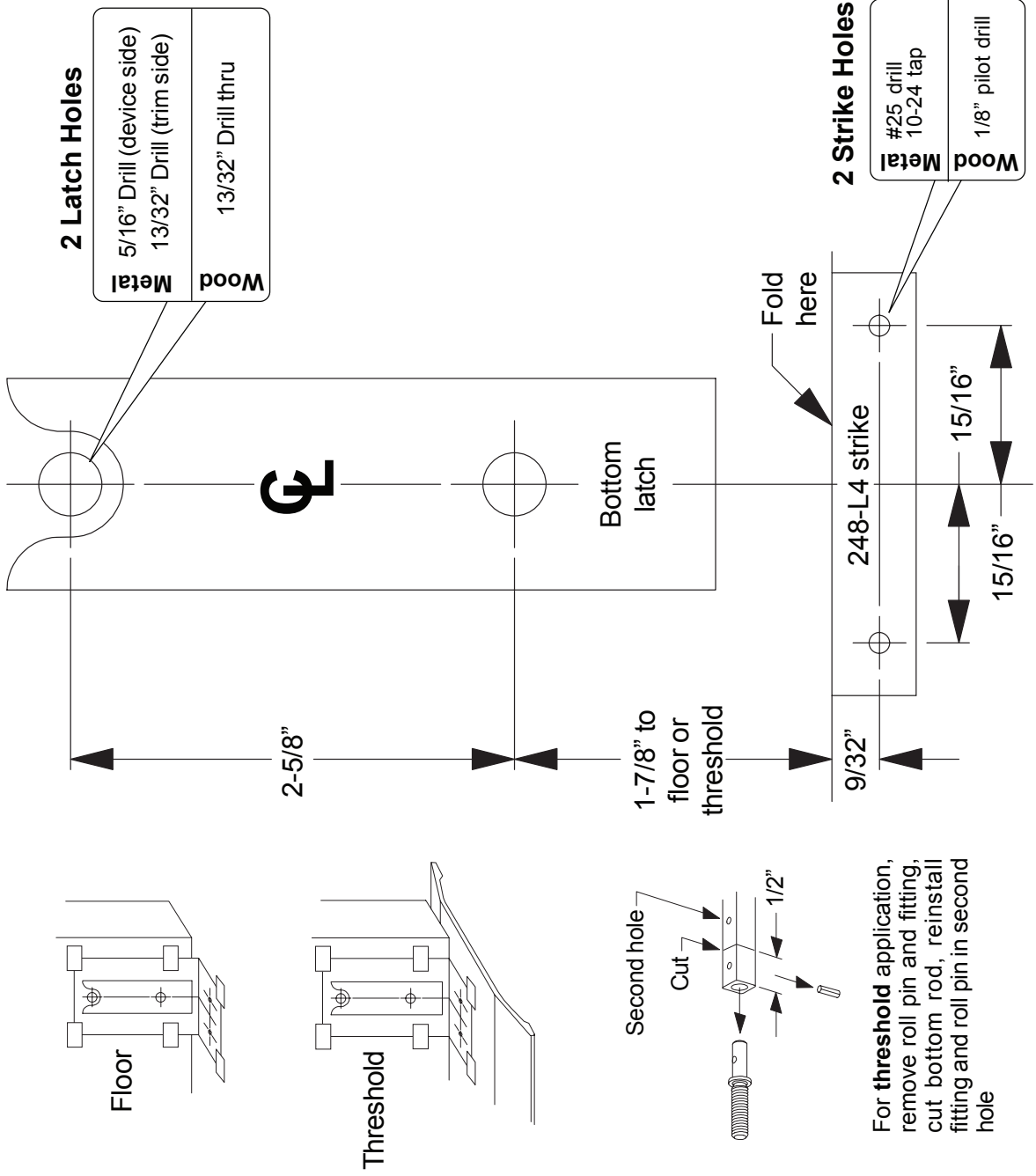

BOTTOM TEMPLATE - CONTINUED

BOTTOM LATCH AND LATCH TRACK

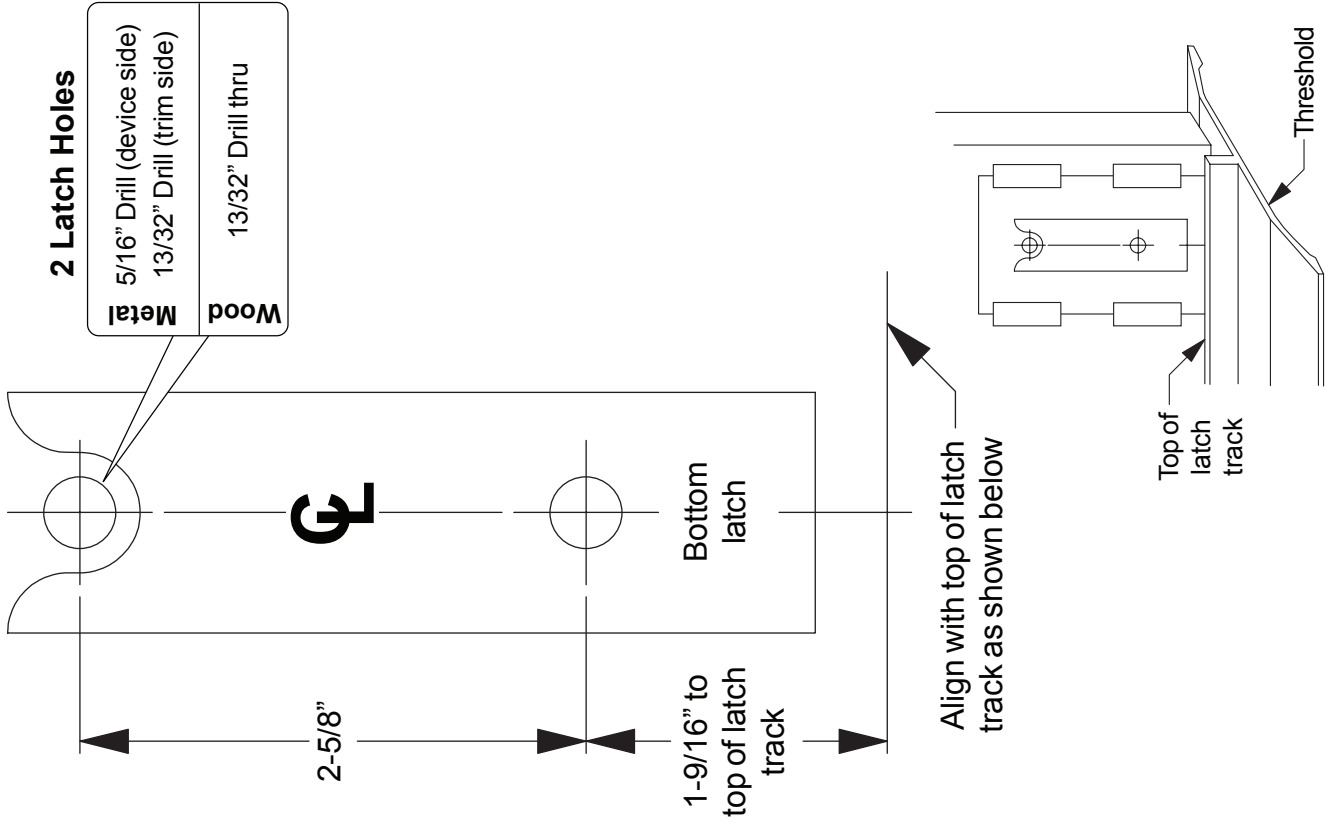

BOTTOM LATCH AND 304L STRIKE

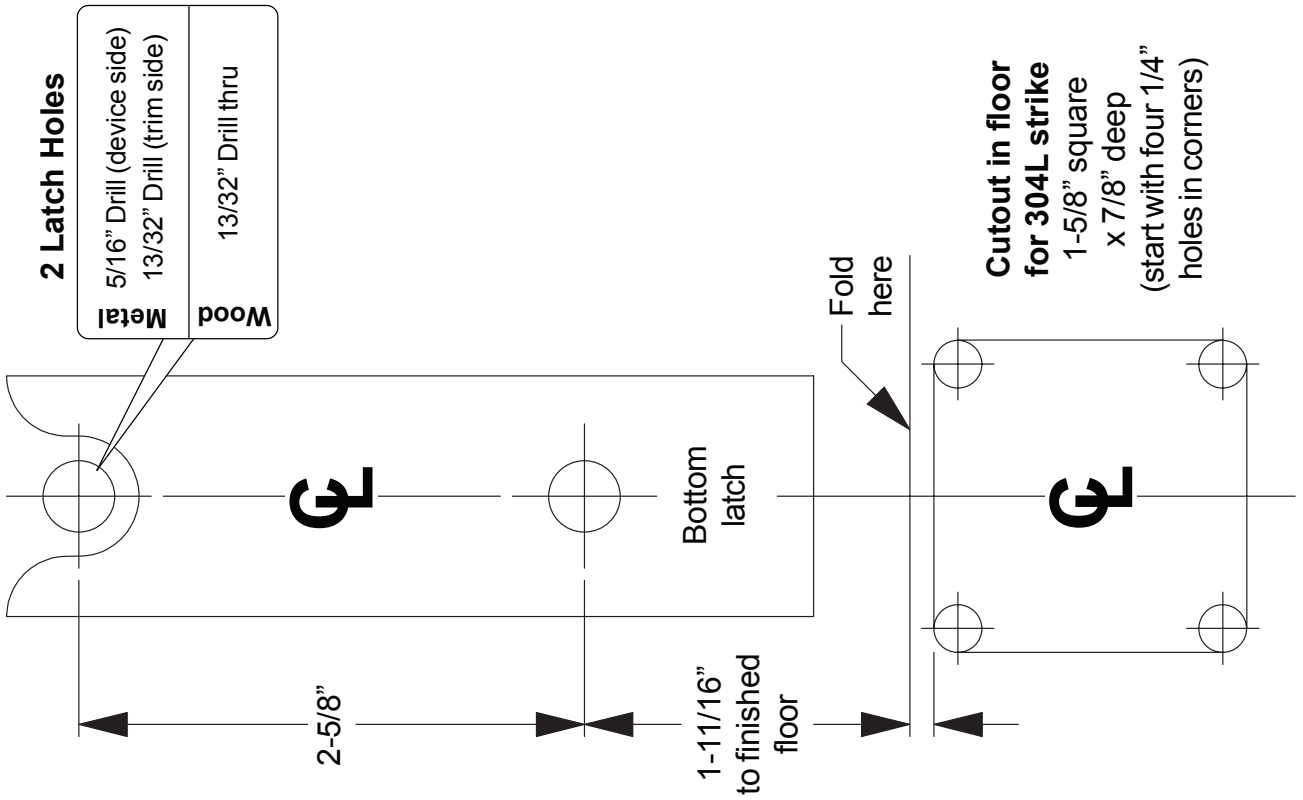

33/3527A Device Template

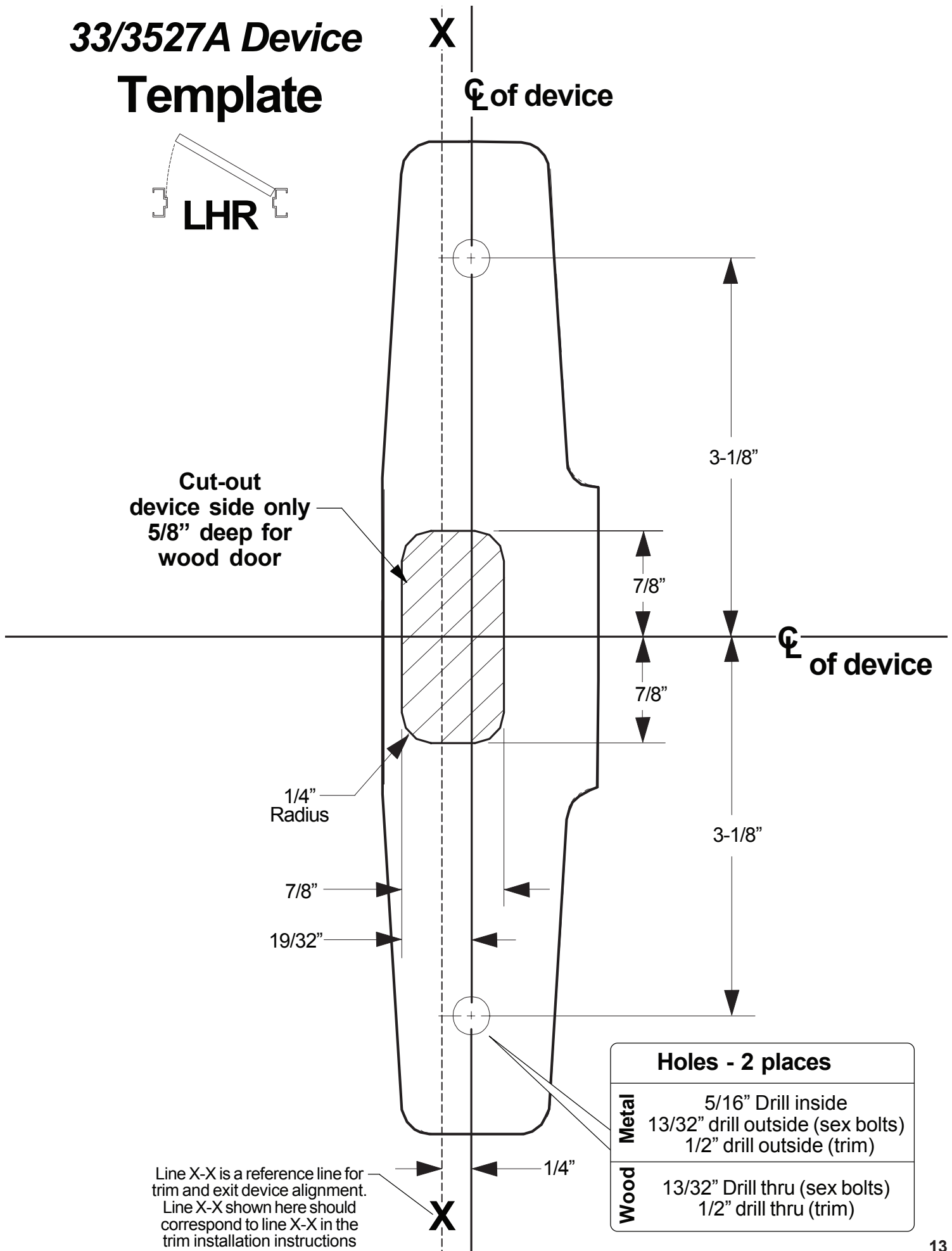
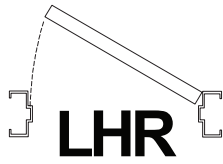

**Cut-out device side only
5/8" deep for wood door**

1/4" Radius

7/8"

19/32"

1/4"

Line X-X is a reference line for trim and exit device alignment. Line X-X shown here should correspond to line X-X in the trim installation instructions

Holes - 2 places	
Metal	5/16" Drill inside 13/32" drill outside (sex bolts) 1/2" drill outside (trim)
Wood	13/32" Drill thru (sex bolts) 1/2" drill thru (trim)

33/3527A Device Template

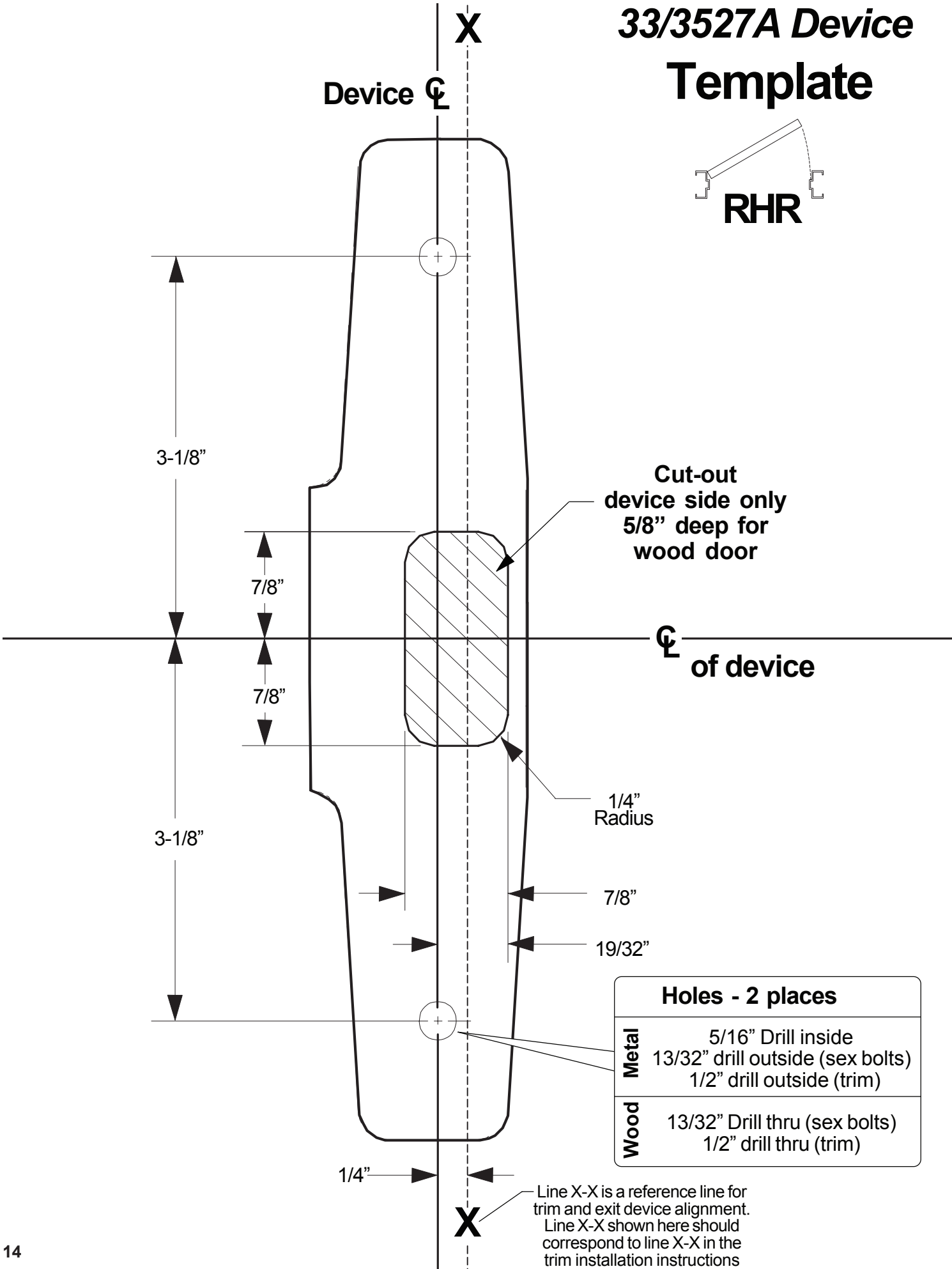
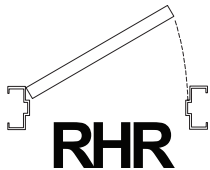

Holes - 2 places	
Metal	5/16" Drill inside 13/32" drill outside (sex bolts) 1/2" drill outside (trim)
Wood	13/32" Drill thru (sex bolts) 1/2" drill thru (trim)

Line X-X is a reference line for trim and exit device alignment. Line X-X shown here should correspond to line X-X in the trim installation instructions

Customer Service

1-877-671-7011 www.allegion.com/us



© Allegion 2016
Printed in U.S.A.
911403-00 Rev. 12/16-d



941255-00

EL/HD-EL

VON DUPRIN®

Conversion Kit

Installation Instructions

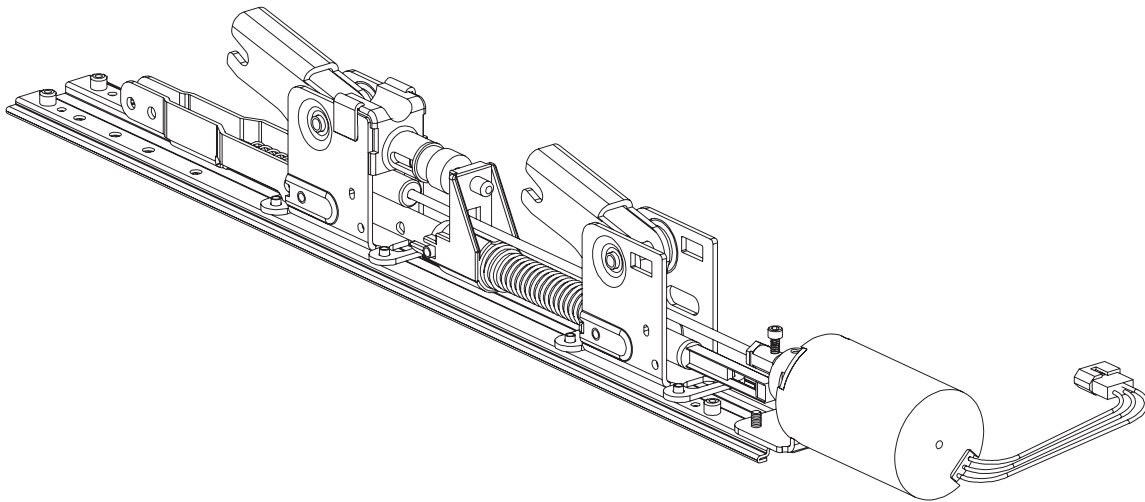

Read All Warnings
Before Starting Installation!

Index

- General Information 2
- Specifications 2
- Parts List 2
- Warnings 2
- Tools Needed 2
- Installation 3
- EL Wiring and Adjustment 12

Customer Service

1-877-671-7011 www.allegion.com/us



© Allegion 2014
Printed in U.S.A.
941255-00 Rev. 01/14-c

GENERAL INFORMATION

This kit converts 33/35, 33A/35A, and 98/99 series devices to electric latch (EL) retraction devices. Before beginning installation, review “Specifications,” “Parts List,” “Warnings,” and “Tools Needed.”

SPECIFICATIONS

Solenoid:

Continuous duty: 24 VDC
Current inrush: 16 A
Current holding: 0.3 A

PARTS LIST

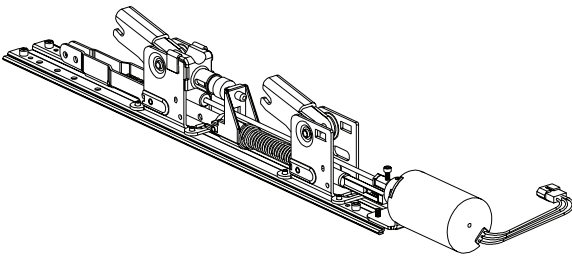

Baseplate with solenoid

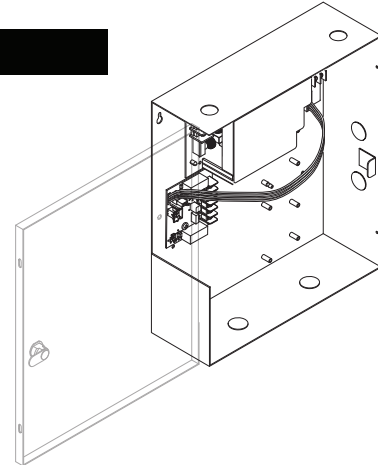

PS914 power supply with 900-2RS logic board
*not in kit



Pin and retaining clip

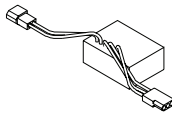

Circuit breaker

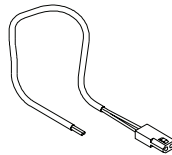

Cable

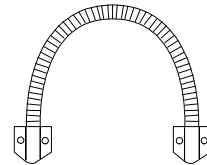

DL-12 door loop
*not in kit

* This part is required for installation but not included in this kit. Contact factory to order.

WARNINGS

1. This kit cannot be used to convert 33/35 Rim devices. Consult factory.
2. Install according to instructions or device will not function and panic or fire label will be void.
3. The solenoid wiring must be attached to the fire alarm system if installed on fire exit hardware.
4. PS914 power supply with 900-2RS logic board must be used for EL device to operate properly.
5. Field wiring between the power supply and the door must be 12 AWG.

TOOLS NEEDED



5/8" dia. drill bit



Flat blade screwdriver

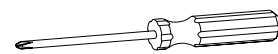

Phillips screwdriver

1 Remove device from door if installed (find correct device on page 3 or 4).

⚠ WARNING

Device and trim must be held securely while removing mounting screws to prevent device and trim from dropping to the floor.

98/99 Rim/Mortise Device

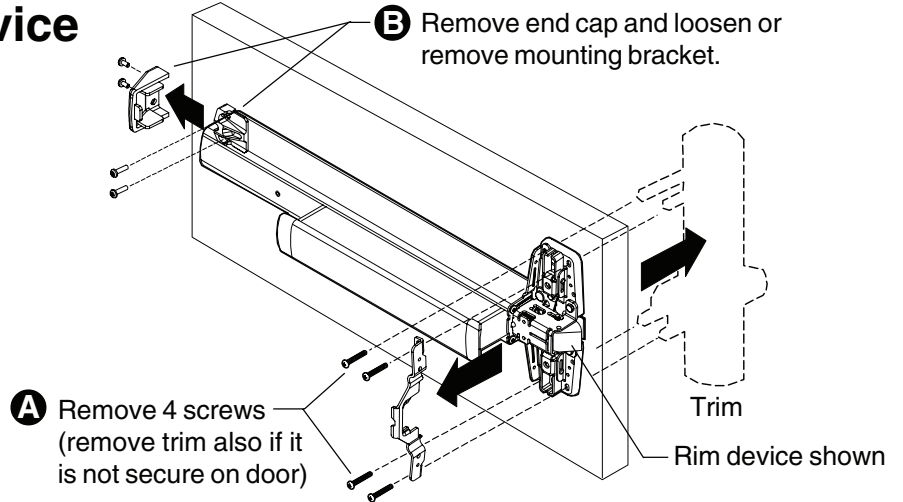

9827/9927 Device

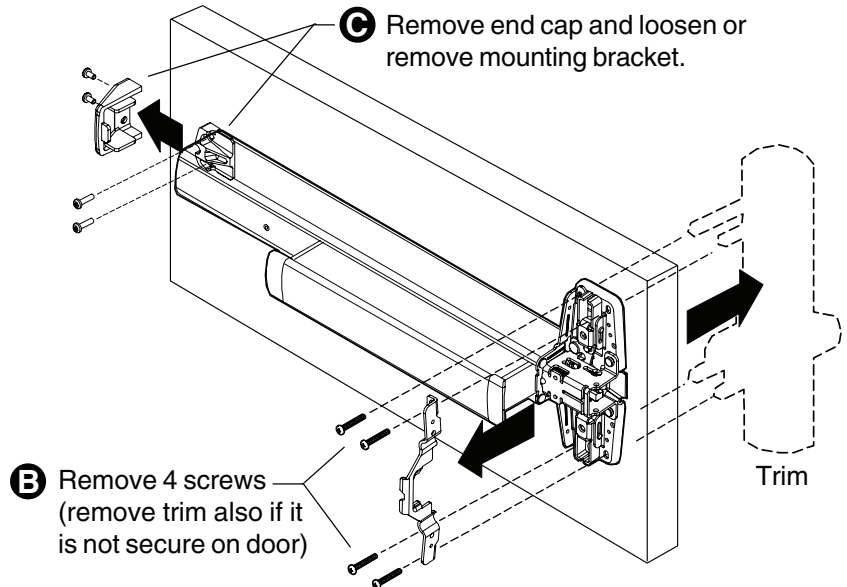
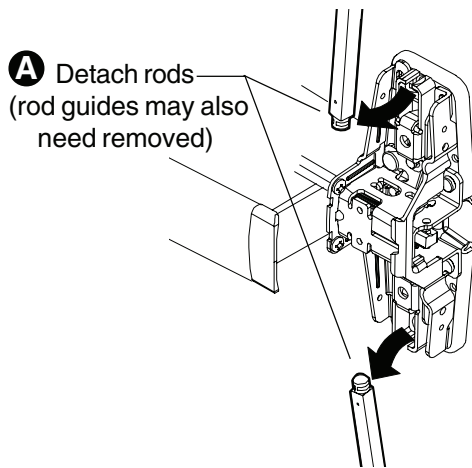

9847/9947 Device

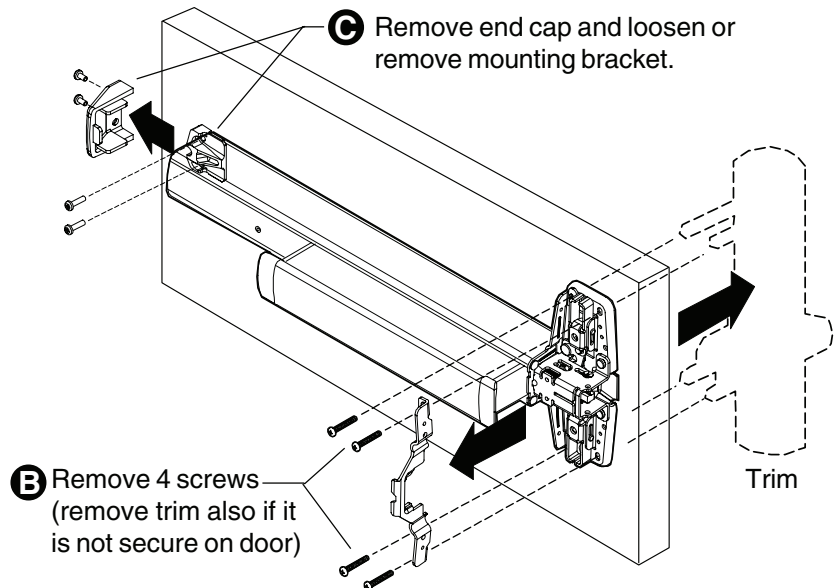
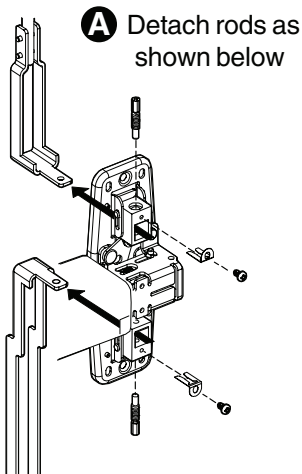

33A/35A Rim Device

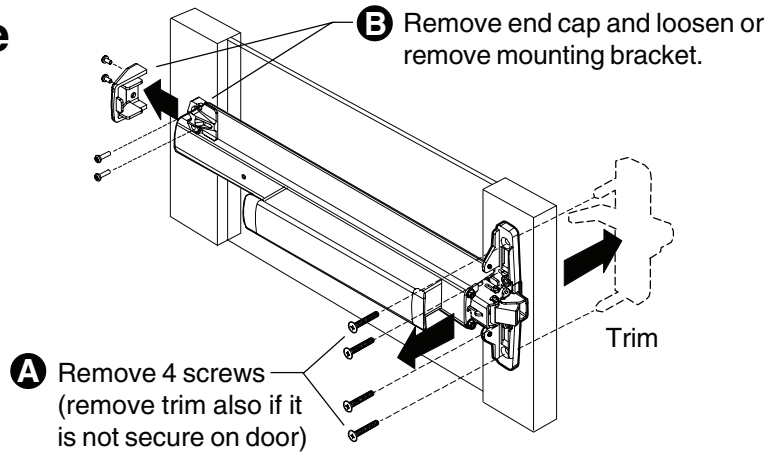

3327/3527 & 3327A/3527A Device

A Detach rods (rod guides may also need removed)

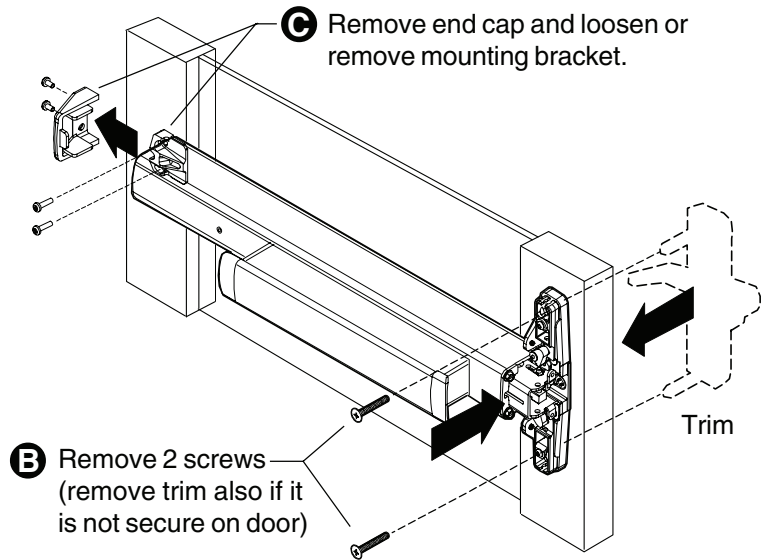
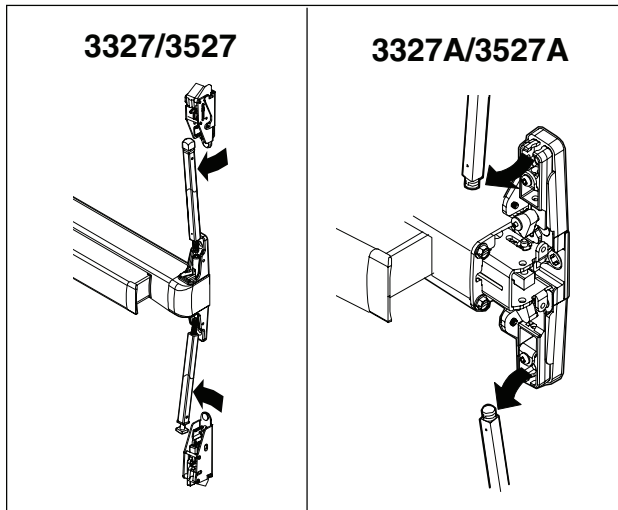

3347/3547 & 3347A/3547A Device

A Detach rods as shown below

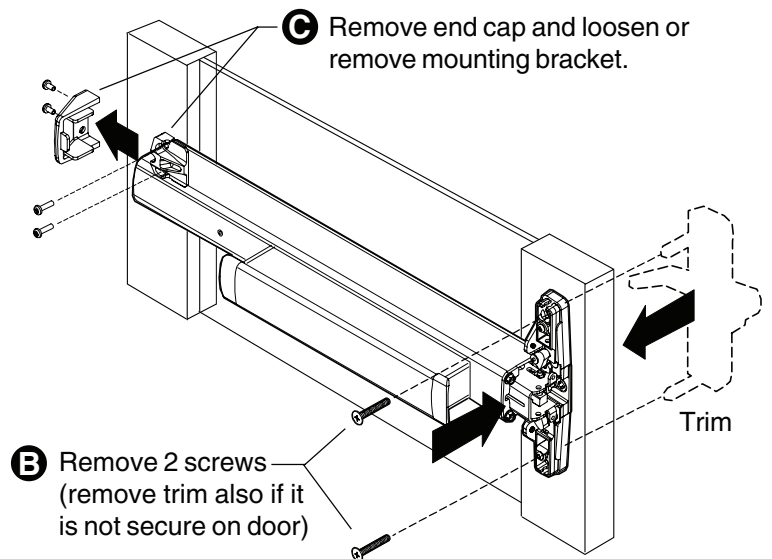
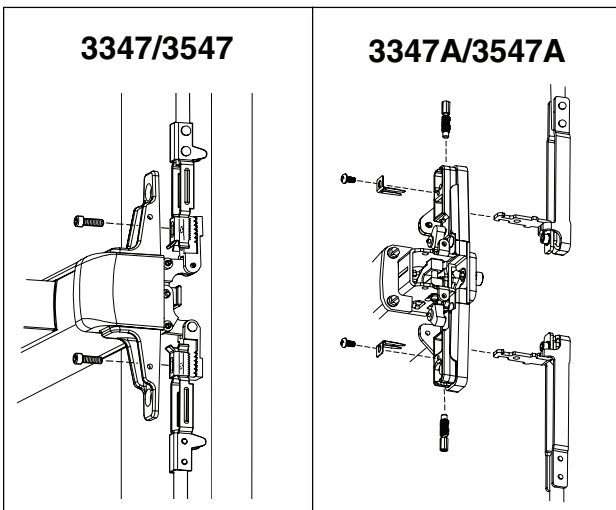

33/35 Device

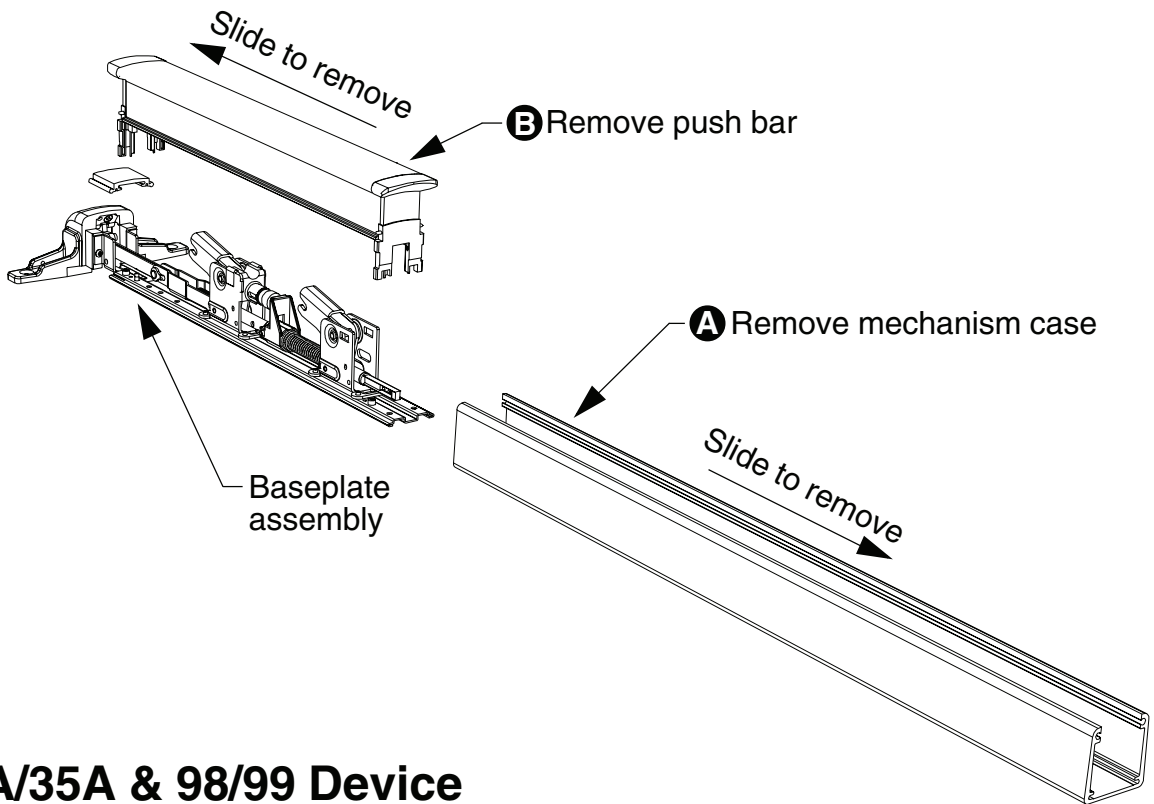

33A/35A & 98/99 Device

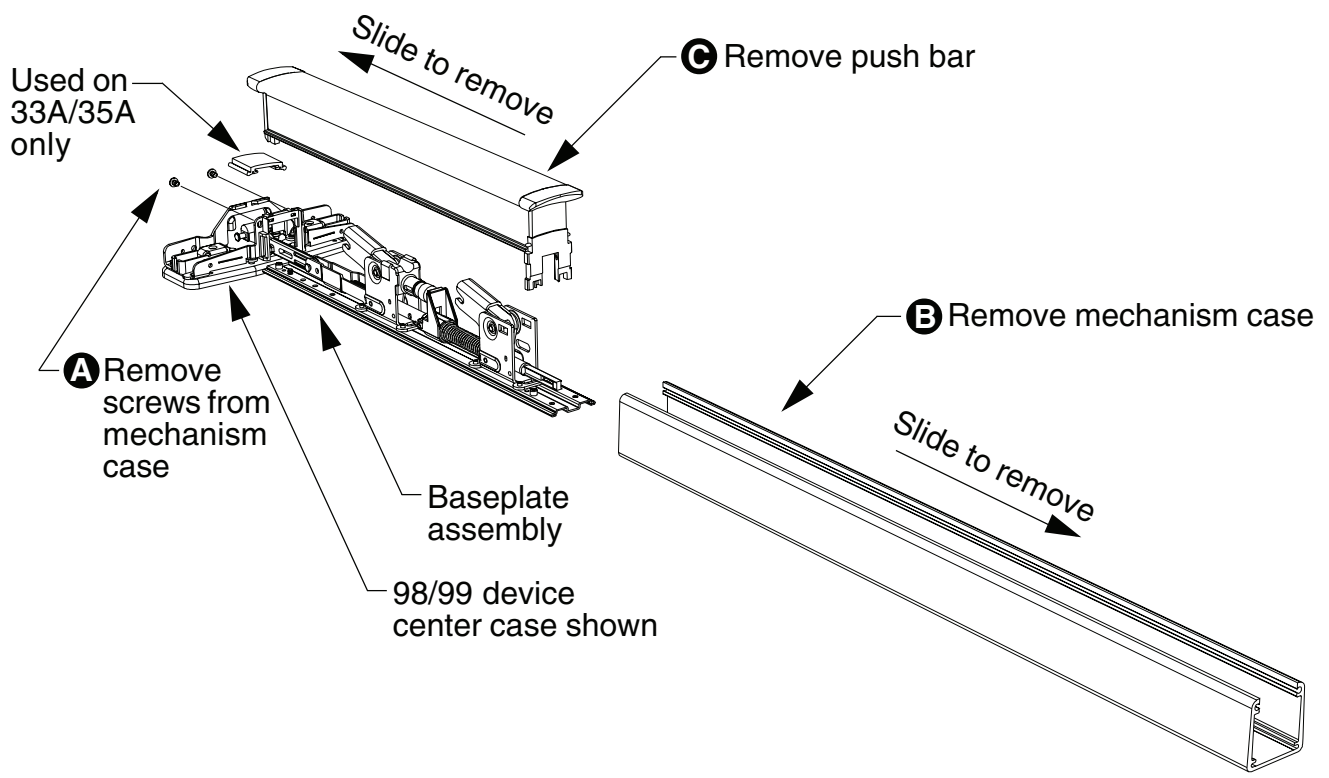

3 Remove main link retaining ring and pin.

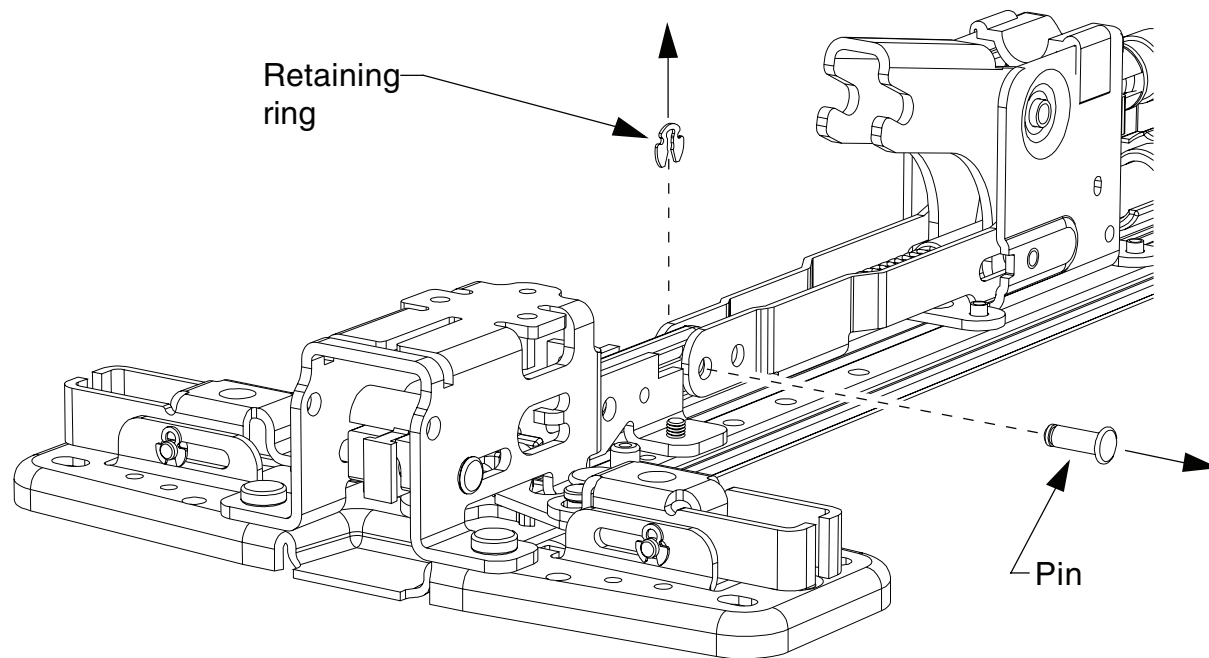

4 Remove screws connecting center case to baseplate.

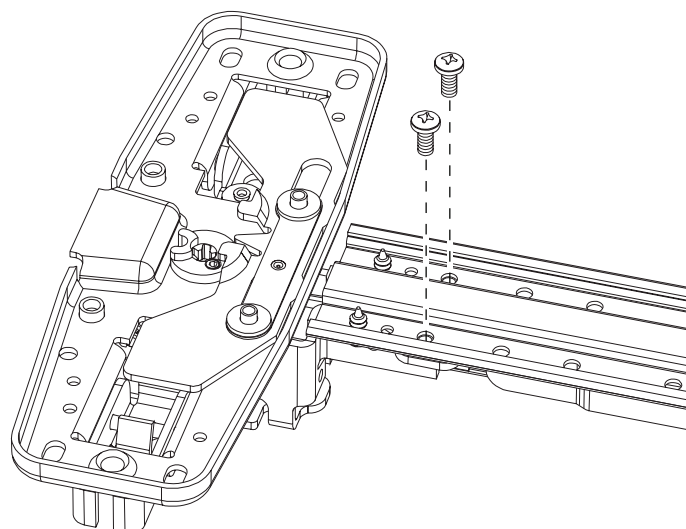

5 Install center case to new EL baseplate.

Warning: Make sure retaining ring is secure in the pin groove. If retaining ring is not secure it could result in an exit device that will not allow exit. This is a serious safety issue.

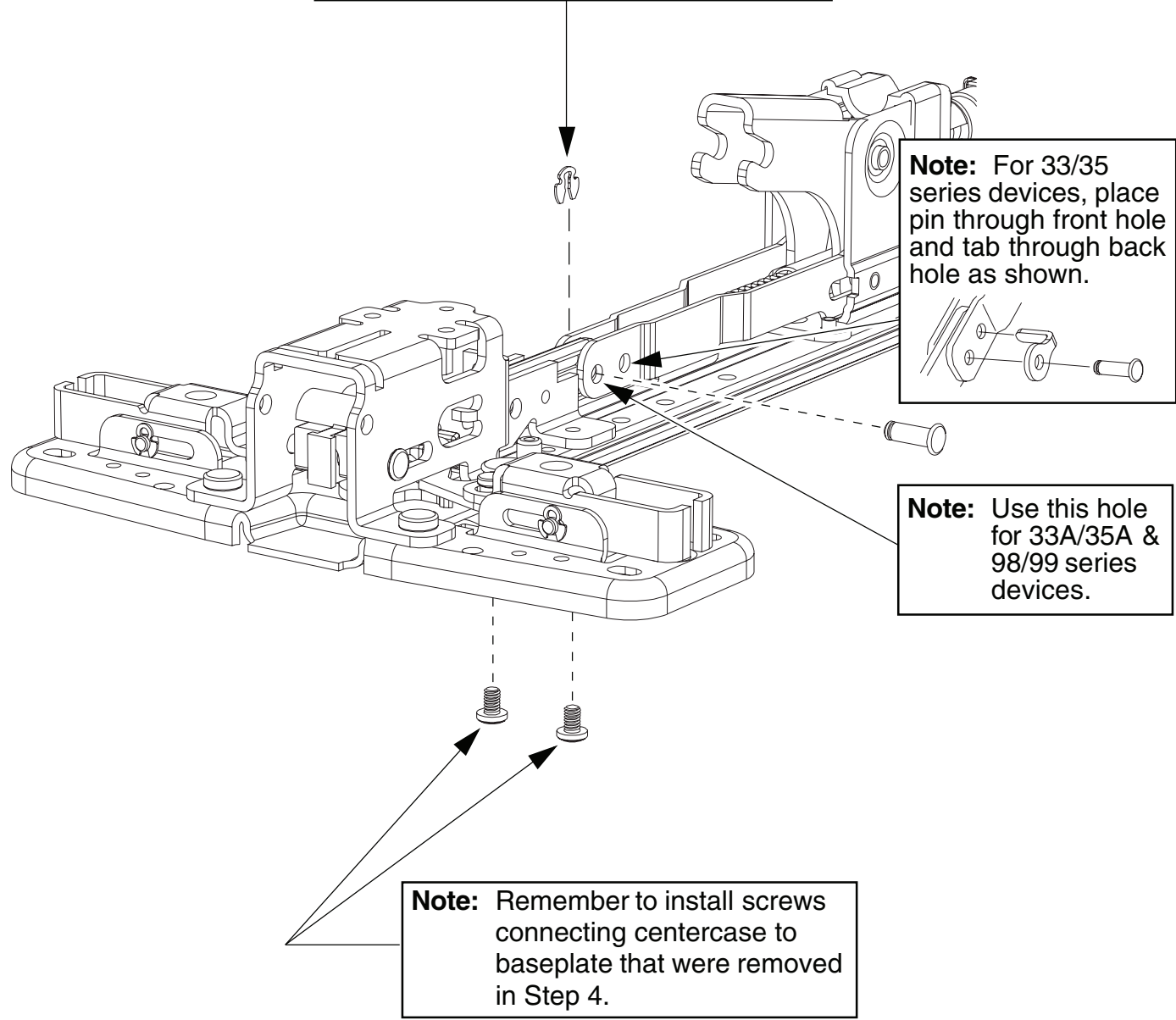

6 Reassemble device.

33/35 Device

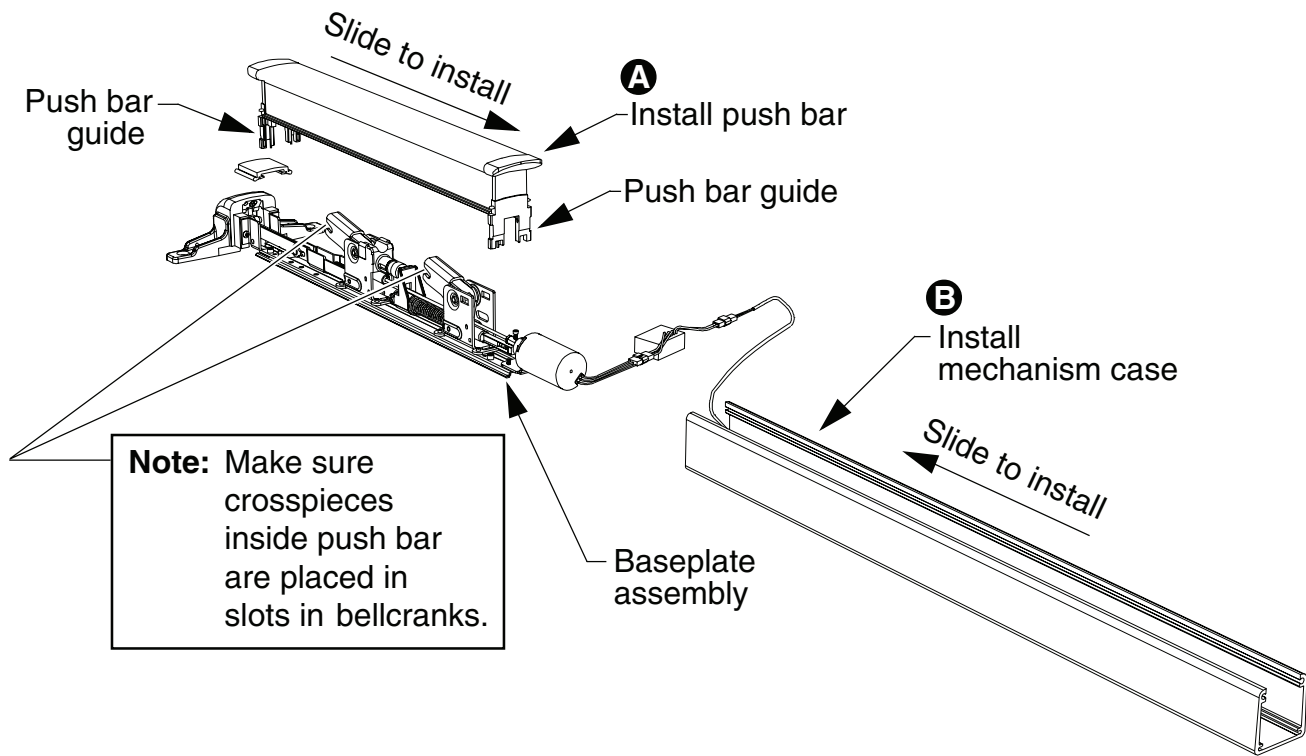

33A/35A & 98/99 Device

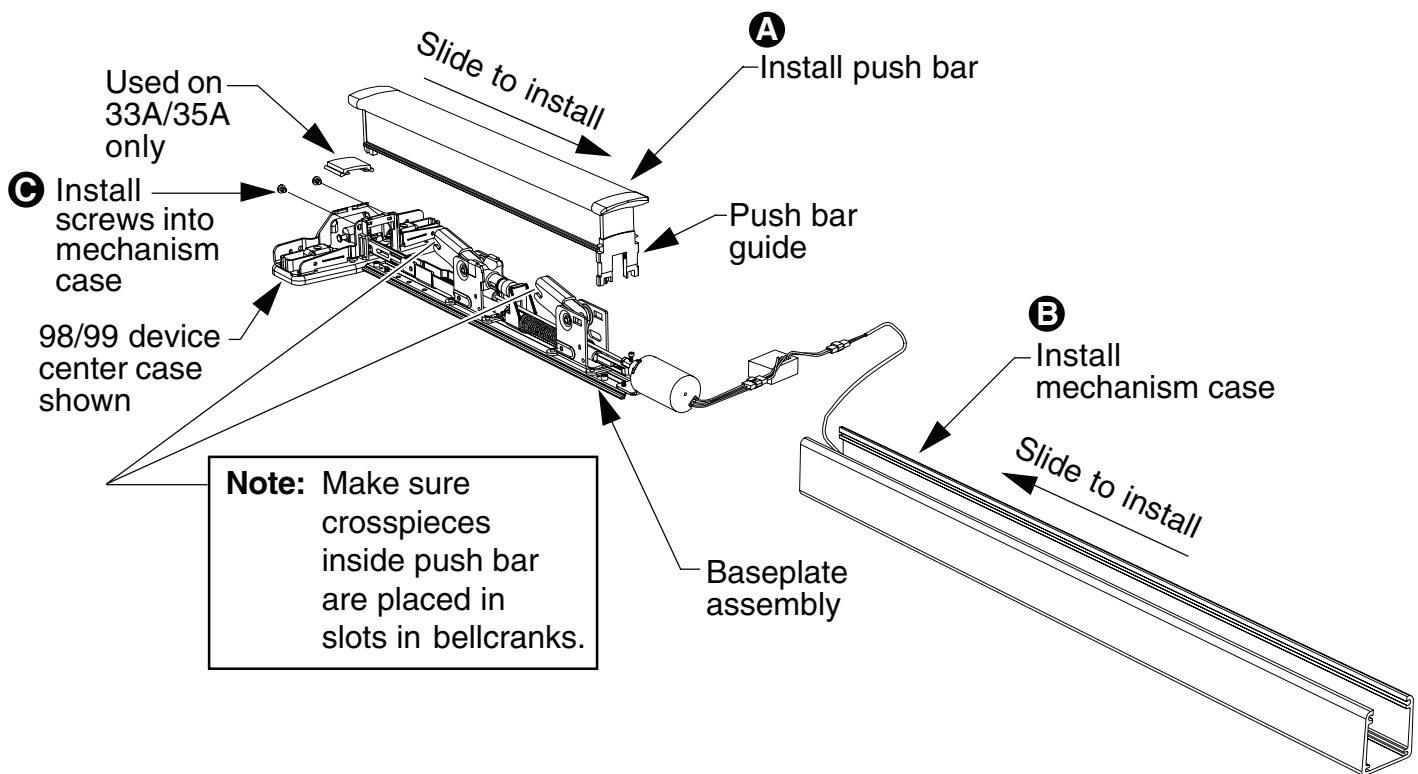

7 Drill solenoid cable hole and install device to door.

- A. Drill 5/8" diameter hole in door centered between end cap bracket mounting holes.
- B. Deburr hole.
- C. Reattach device and trim to door.

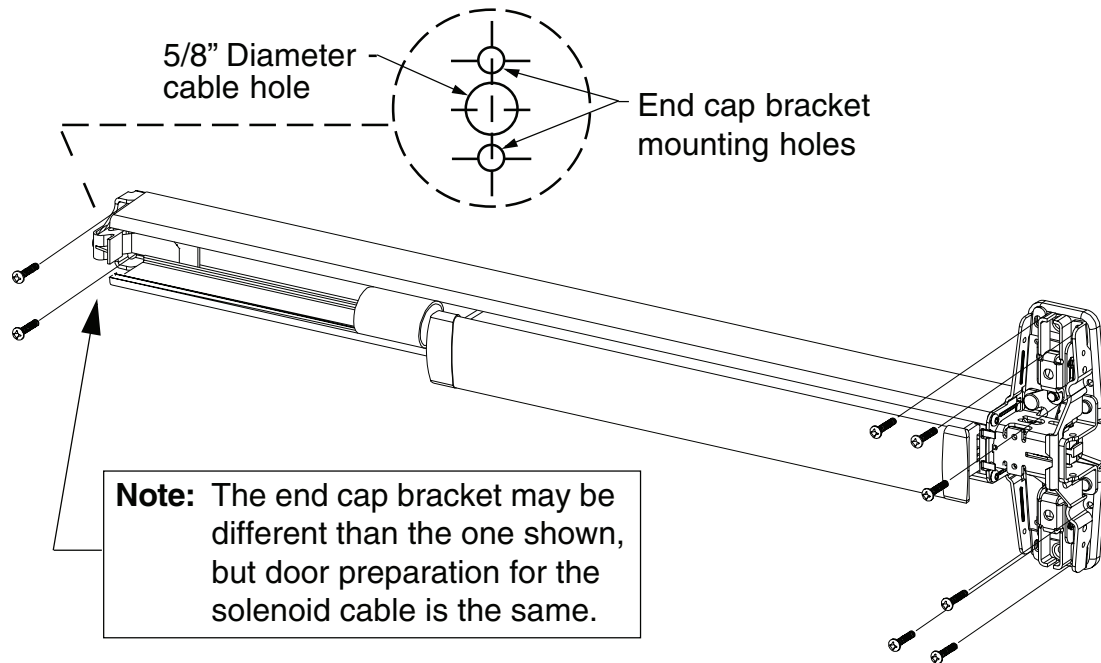

8 Route cable through hole in door.

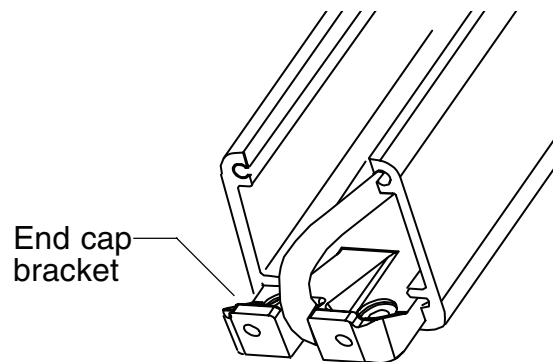

9 Install cover plate and end cap.

- A. If cover plate has a dogging key hole, rotate cover plate so hole is near end cap for standard EL device and near pushbar for HD-EL device.
- B. Install anti-rattle spring.
- C. Install cover plate.
- D. Install end cap.

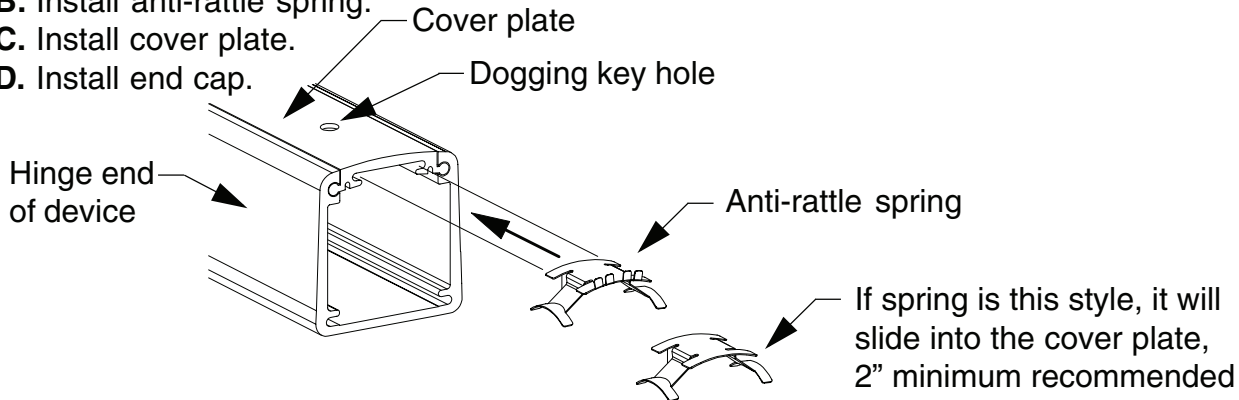

10 For vertical devices, reattach rods.

Reattach rods in reverse of when they were detached on pages 3 and 4.

11 Adjust rods as needed on vertical devices (find correct device on page 10 or 11).

9827/9927 Device or 3327A/3527A Device

Adjust top and bottom rod (screw rod into or out of latch) until adjusted as shown.

Note: On bottom latch, make sure latch bolt clears floor when door is swung open.

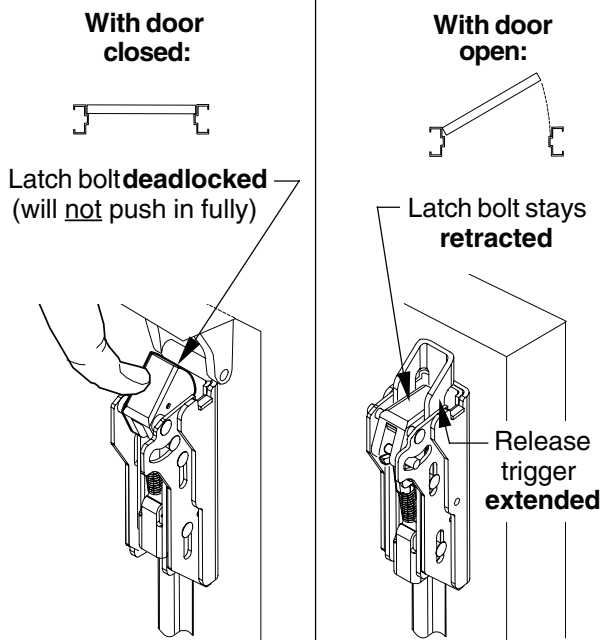

3327/3527 Device

Adjust top and bottom rod (screw rod into or out of center case rod connector) until adjusted as shown.

Note: On bottom latch, make sure latch bolt clears floor when door is swung open.

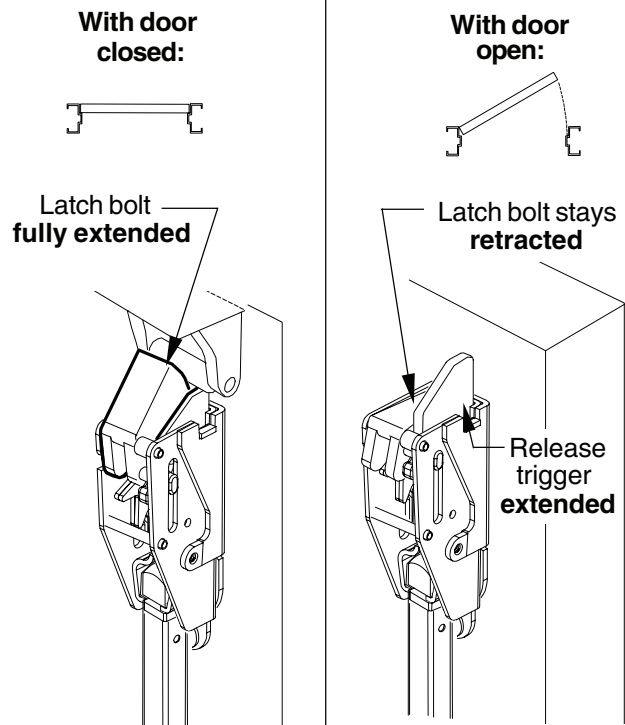

9847/9947 Device or 3347A/3547A Device

- A. Open door and release top latch bolt as shown (Figure 11-1).

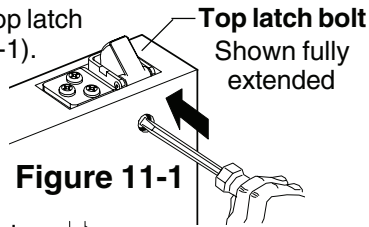

- B. Loosen bottom locking screw (Figure 11-2).

- C. Disconnect bottom vertical rod by removing bottom adjusting screw.

- D. Loosen top locking screw.

- E. Rotate top adjusting screw clockwise until top latch bolt is fully extended (Figure 11-1).

- F. Check top latch bolt for deadlocking (latch bolt should not push in fully).

- G. Turn top locking screw in. Do not over-tighten

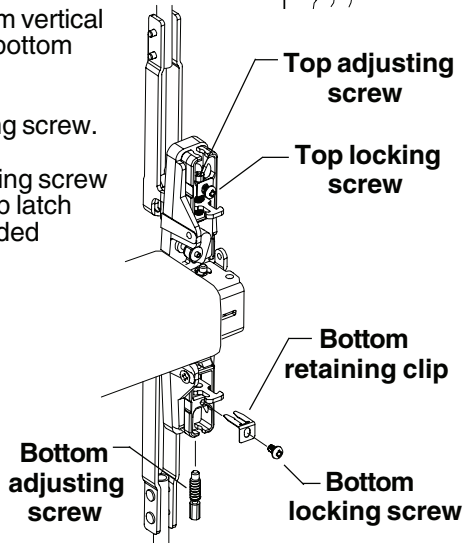

Figure 11-2

- H. Depress pushbar and release. **Latch bolt retracted** (flush with latch case)

- I. Make sure top latch bolt stays retracted as shown.

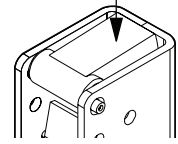

Figure 11-3

- J. Install bottom adjusting screw, retaining clip, and locking screw (Figure 11-2).

- K. With top latch bolt still retracted, adjust bottom rod so latch bolt clears floor and bottom strike.

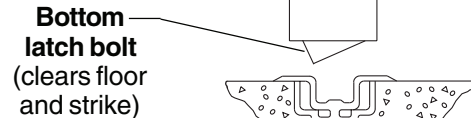

Figure 11-4

- L. Turn bottom locking screw in. Do not over-tighten.

- M. Close door and push up on bottom latch bolt to verify it is deadlocked (will not push in fully).

- N. Check device operation by opening and closing door several times from the outside.

Redo adjustment procedure if :

- Top latch bolt is not held retracted
- Bottom latch bolt does not clear floor and bottom strike

3347/3547 Device

- A. Loosen top and bottom adjusting screws.

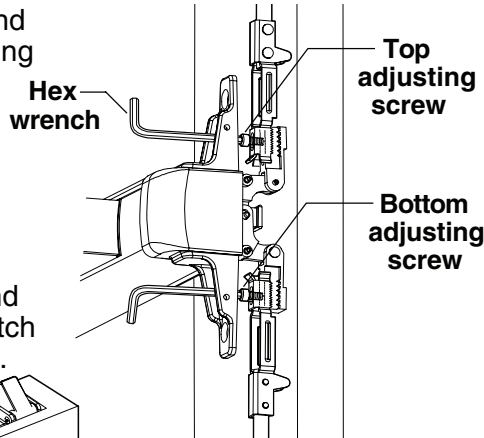

- B. Open door and release top latch bolt as shown.

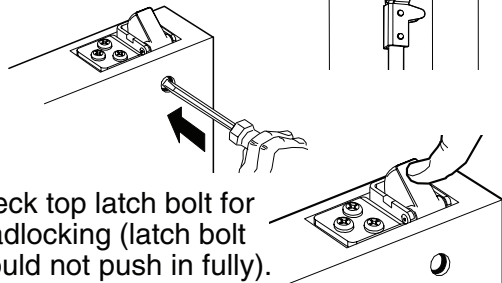

- C. Check top latch bolt for deadlocking (latch bolt should not push in fully).

- D. With top latch bolt still fully extended and pushbar in full up position (not depressed), tighten top adjusting screw.

- E. Depress pushbar and release. **Latch bolt retracted** (flush with latch case)

- F. Make sure top latch bolt stays retracted as shown.

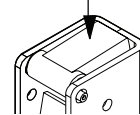

- G. With top latch bolt still retracted, push bottom latch bolt up until it clears floor and bottom strike and hold it there.



- H. Tighten bottom adjusting screw.

- I. Close door and push up on bottom latch bolt to verify it is deadlocked (will not push in fully).

- J. Check device operation by opening and closing door several times from the outside.

Redo adjustment procedure if :

- Top latch bolt is not held retracted
- Bottom latch bolt does not clear floor and bottom strike

12 Complete wiring.

12 AWG required for distances up to 200'
14 AWG permitted for distances 0-100'

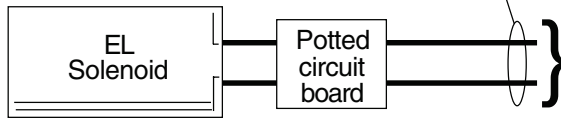

ELECTRICAL SPECIFICATIONS

Voltage: 24 VDC
Current: 16 A inrush (0.3 sec.)
0.25 A holding

NOTE

When power is applied to the **potted circuit board**, the solenoid receives a momentary signal to retract and a separate signal to hold as long as power is applied. When attempting to retract solenoid again, power must be removed from the circuit and reapplied.

Troubleshooting solenoid operation

If the solenoid fails to retract the latch bolt when power is applied, recheck wiring for proper connections.

If solenoid retracts latch bolt momentarily but will not remain in energized position:

1. Check wiring for proper connections, gauge, and distances.
2. Check for latch bolt binding caused by improper strike installation, warped door, etc. Also check adjustment of vertical rods.

EL WIRING

Solenoid draws 16 A inrush current from PS914. Solenoid must be wired to a 900-2RS logic board:

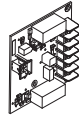

If 900-2RS logic board, refer to instructions 44487056.

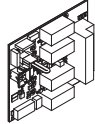

If 900-4RL logic board, refer to instructions 44487080.

Solenoid

Potted Circuit Board
Install after device has been mounted on door

Do not cut device with potted circuit board installed

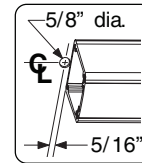
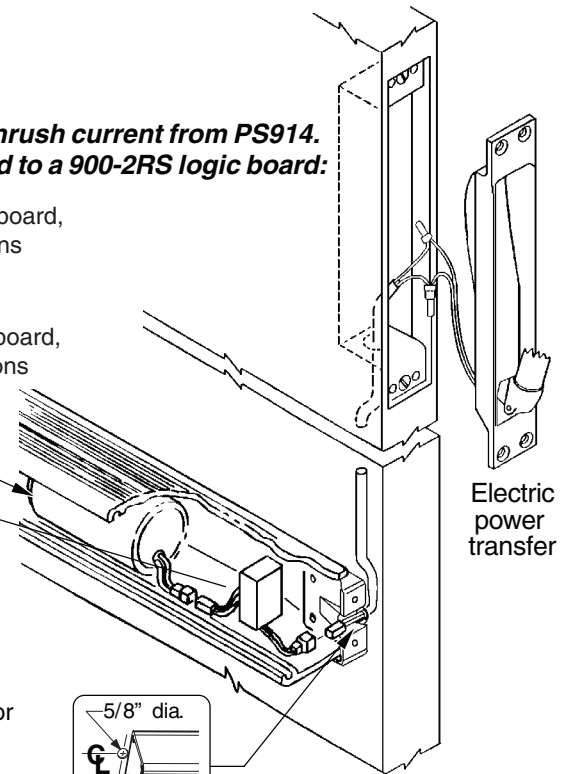

Drill 5/8" dia. wire access hole thru device side of door.

13 Adjust EL device for proper function.

A. Check for proper function:

1. Make sure device is not dogged.
2. Depress pushbar and make sure latch bolt(s) retracts and extends fully (see Figure 13-1).
3. Electrically energize solenoid and hold.
4. Check latch bolt(s) for full retraction (must clear strike, see Figure 13-1).
5. Release solenoid and check latch bolt extension (see Figure 13-1).
6. Continue to Section B if device does not function electrically.

B. Determine if dogging rod adjustment is too long or short:

1. The dogging rod adjustment is too **long** if latch bolt does not retract and clear strike (see Section C for adjustment).
2. The dogging rod adjustment is too **short** if latch bolt does not fully extend **or** latch bolt fully retracts but solenoid releases while energized (see Section D for adjustment).

C. Adjust solenoid if dogging rod is too **long** (see Figure 13-2):

1. Remove end cap ① and dogging cover ②.
2. Loosen cap screw ③.
3. Hold plunger ⑤ depressed in solenoid housing ⑥.
Note: Push hard against plunger ⑤ to overcome an internal spring in solenoid housing ⑥.
4. Turn threaded bushing ④ in to shorten dogging rod ⑦ so latch bolt fully retracts.
5. Tighten cap screw ③.
Note: Cap screw ③ must be tightened against flat on threaded bushing ④. Apply a few drops of Loc-Tite 222 to threads of cap screw ③.
6. Replace dogging cover ② and end cap ①.
7. Return to Section A to check for proper function.

Note: Rim device shown, see pages 10 and 11 for verticals

Latch bolt extended 3/4"
Latch bolt retracted Flush within 1/16"



Figure 13-1

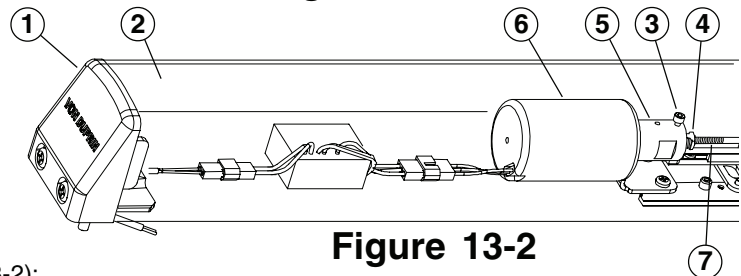

Figure 13-2

D. Solenoid adjustment if dogging rod adjustment is too **short** (see Figure 13-2):

1. Remove end cap ① and dogging cover ②.
2. Loosen cap screw ③.
3. Hold plunger ⑤ depressed in solenoid housing ⑥.
4. Turn threaded bushing ④ out to lengthen dogging rod ⑦ so plunger ⑤ just bottoms in solenoid housing ⑥ and latch bolt is fully retracted.
Note: Push hard against plunger ⑤ to overcome an internal spring in solenoid housing ⑥.
5. Tighten cap screw ③.
Note: Cap screw ③ must be tightened against flat on threaded bushing ④. Apply a few drops of Loc-Tite 222 to threads of cap screw ③.
6. Replace dogging cover ② and end cap ①.
7. Return to Section A to check for proper function.