

PREMIUM TRIM SKIRT FOR THE 4300

USING THE TRIM SKIRT

The skirt can be used to clean up the cut line of the frame face during installation. The Trim Skirt comes with 2 longer screws (included) for fastening to the top and bottom of the 4300.

Available in 3 powdercoat finishes: Aluminum (ALUM), Black (BLK), & Dark Bronze (DKBZ) which can match the finish of the faceplate and Fascias.

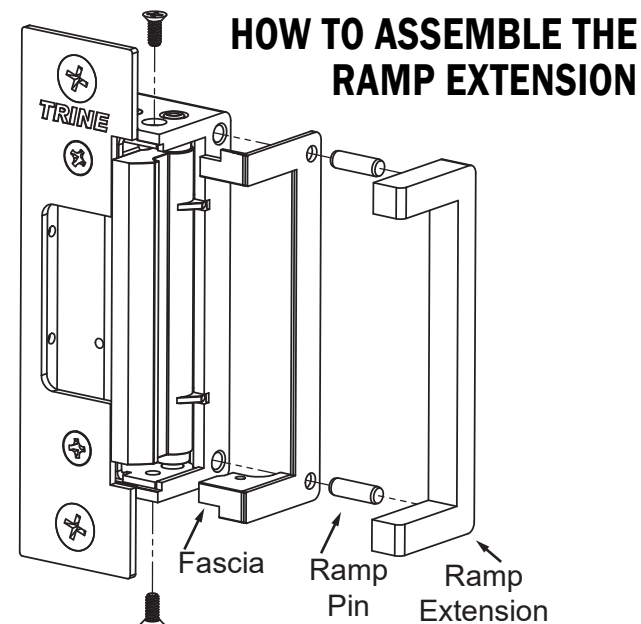

HOW TO ASSEMBLE THE RAMP EXTENSION

4300 ELECTRIC STRIKE INSTALLATION INSTRUCTIONS



TRINE 4300 THE ONE BOX SOLUTION FOR CYLINDRICAL LOCKS AND DEADLATCHES

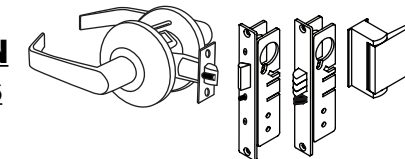

Congratulations on the purchase of this quality TRINE security product. This product has been designed to install easily, perform reliably, and provide years of trouble free security.

BEFORE proceeding with your installation, please review the following list of features. If you have any questions after reading this document please call TRINE's TECHNICAL SUPPORT (203) 730-1756 EXT. 447, or visit the TRINE web site at www.trineonline.com

TROUBLESHOOTING THE COMPLETED INSTALLATION:

DO NOT APPLY A VOLTAGE OF MORE THAN 10% OVER THE RATED OPERATING VOLTAGE OF THE STRIKE OR THE SOLENOID WILL BE DAMAGED

SYMPTOM: Electric release is not actuating:

1. Verify proper voltage is present AT THE STRIKE. If voltage is present, the strike may have been affected during the installation, or dirt or debris may be preventing proper operation. Ensure that all moving parts are clean. **DO NOT LUBRICATE THE SOLENOID.**
2. If voltage IS NOT present:
 - Verify Circuit breaker is on
 - Verify voltage at the transformer/power supply output.
 - Verify that there are no additional external switches or devices which may be interrupting your circuit.
 - Check for damaged wiring or bad wire splices.

SYMPTOM: Door will not open but strike is working

- First, check to see if the electric strike works properly while the door is open.
- Check for proper lock-latch engagement
- Check for pressure from the door on the electric strike by following these steps:
Push the door from the outside, try and relieve the bolt to latch pressure and actuate the 4300. While the 4300 is unlatched swing the door open. If the door opens, then the bolt may be applying pressure to the latch. Adjust the position of the 4300 to relieve the pressure.

Possible remedies include:

1. Re-adjust door closer.
2. Remove door silencers.
3. Remove, or trim, weather stripping around the door.
4. Adjust electric strike position if possible.
5. Correct excessive warping of door.

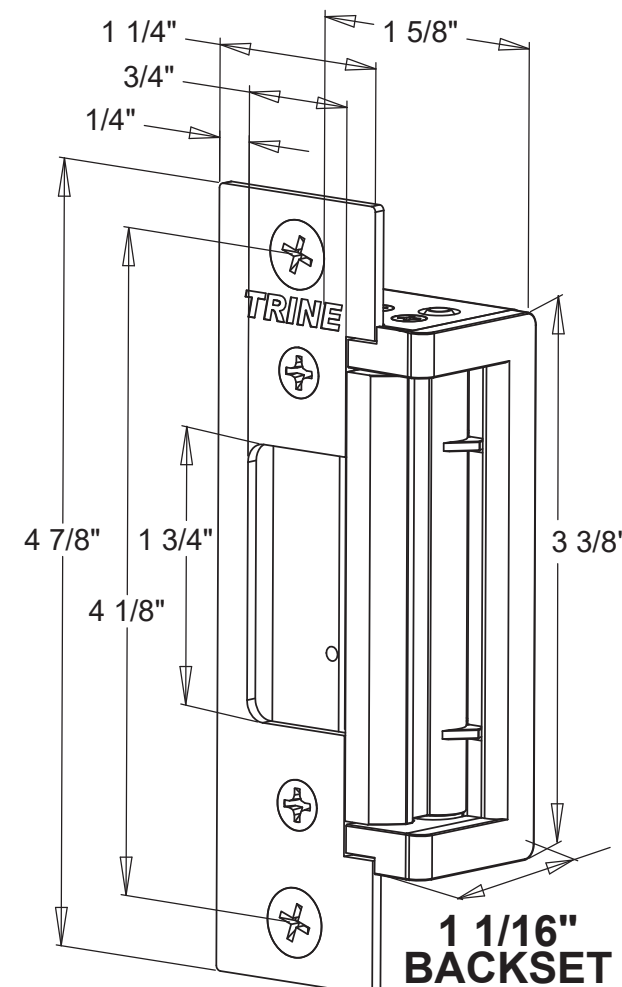

WHAT'S IN THE BOX:

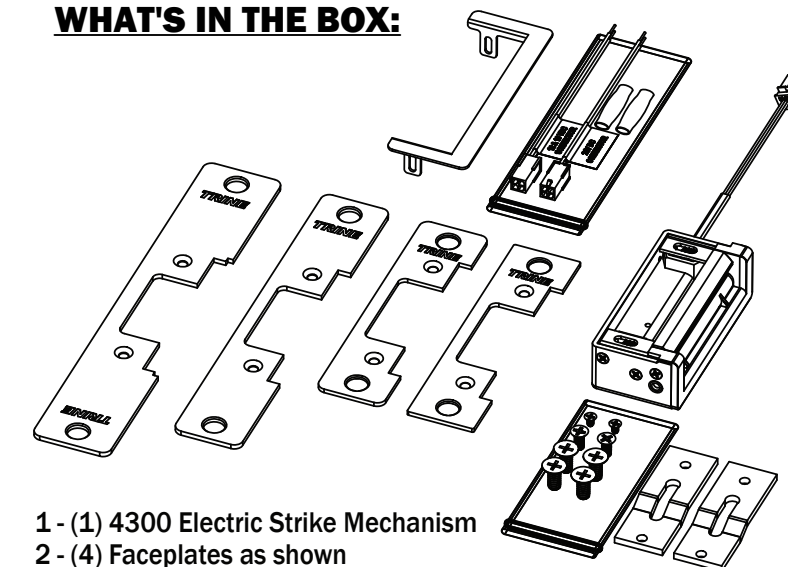

- 1 - (1) 4300 Electric Strike Mechanism
- 2 - (4) Faceplates as shown
- 3 - (4) #12-24 x 1/2 inch Philips Mounting Screws
- 4 - (2) #8-32 Face Plate Mounting Screws
- 5 - (2) Quick Connect Socket & Wire Assembly 12VDC & 24VDC Version
- 6 - (2) Sealed Crimp Connectors
- 7 - (1) Frame Trim Skirt & (2) Screws
- 8 - (2) Mounting Tabs

4300 ELECTRICAL CHARACTERISTICS:

Voltage	Current Draw	Power Consumption	Resistance
12DC	.310 Amps	3.72 Watts	39 Ohms
24DC	.140 Amps	3.36 Watts	171 Ohms
12AC @ 50-60Hz	.280 Amps	3.36 Watts	39 Ohms
16AC @ 50-60Hz	.380 Amps	6.08 Watts	39 Ohms
24AC @ 50-60Hz	.550 Amps	13.20 Watts	39 Ohms

When removing the connector and using the wires direct;
Blue Wire is Common,
Red Wire accepts 12DC & 12-16AC
Brown Wire accepts 24DC.

RS IS FAILSAFE ACTION (LOCKS WITH POWER) AND IS 12 & 24 VDC ONLY

OPERATING TEMP RANGE: -20 °C TO +40 °C

DO NOT APPLY A VOLTAGE OF MORE THAN 10% OVER THE RATED OPERATING VOLTAGE OF THE STRIKE OR THE SOLENOID WILL BE DAMAGED

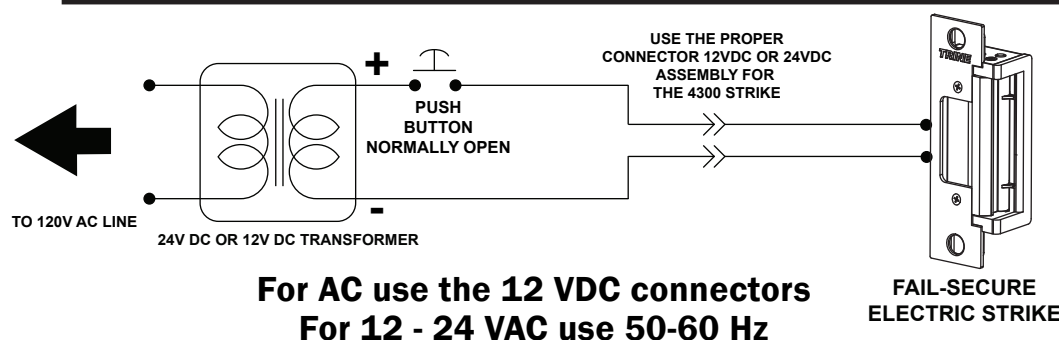

WIRING DIAGRAMS

USE CLASS 2 SURGE PROTECTED POWER SUPPLY WITH THIS ELECTRIC STRIKE.

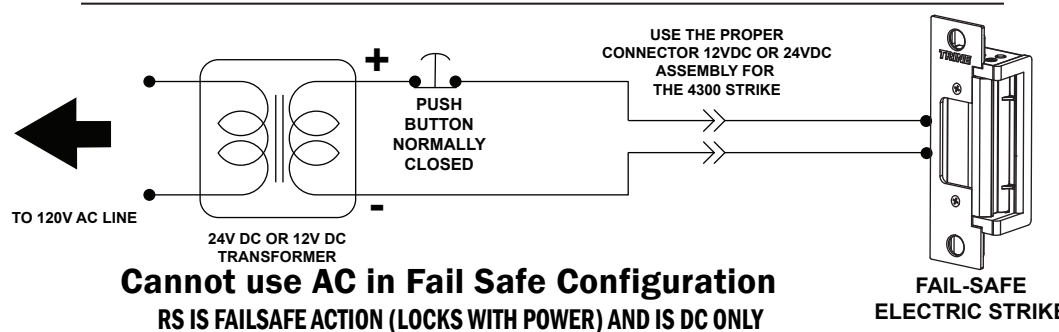

PHONE: (203) 730-1756
FAX: (203) 730-1781
2 PARKLAWN DRIVE
BETHEL, CT 06801
email: customerservice@trineonline.com
website: www.trineonline.com

V. 24.0417

The 4300 is ETL recognized for:
UL1034 Burglary Listed



The 4300 is WH recognized for UL294

Feature	Level
Destructive Attack	II
Line Security	I
Endurance	IV
Standby Power	I

4300 OPTIONS:

- 4300RS - FAIL SAFE CONFIGURATION
(Voltages 12 & 24 VDC only)
- BZ-12 - 12VDC Piezo Buzzer
- BZ-24 - 24VDC Piezo Buzzer

FRAME PREPARATION

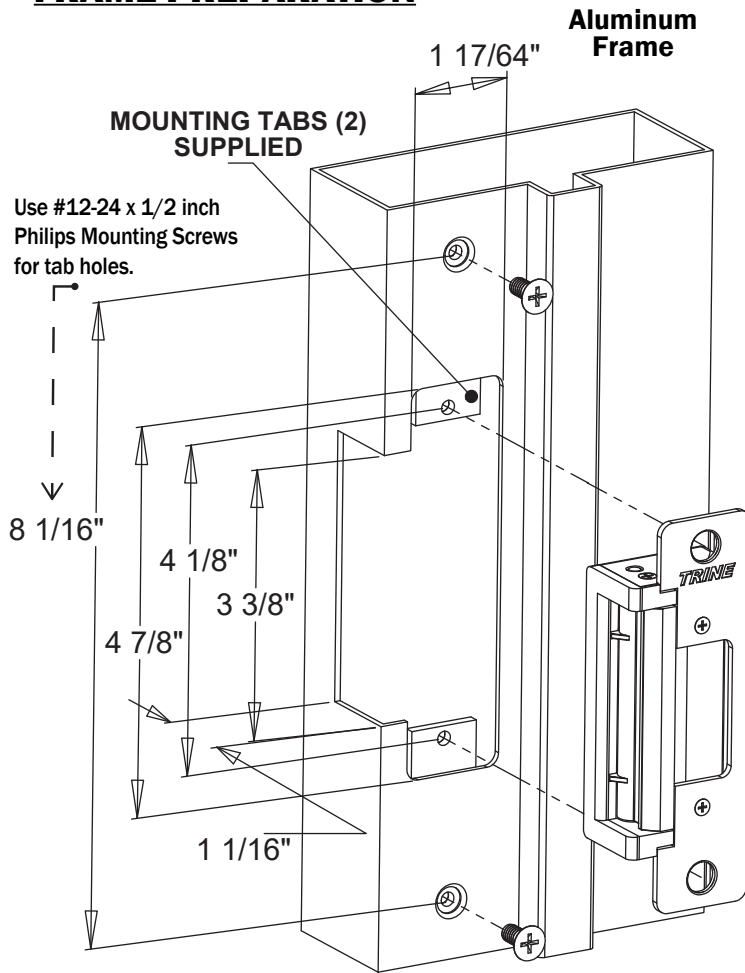

Metal Frame

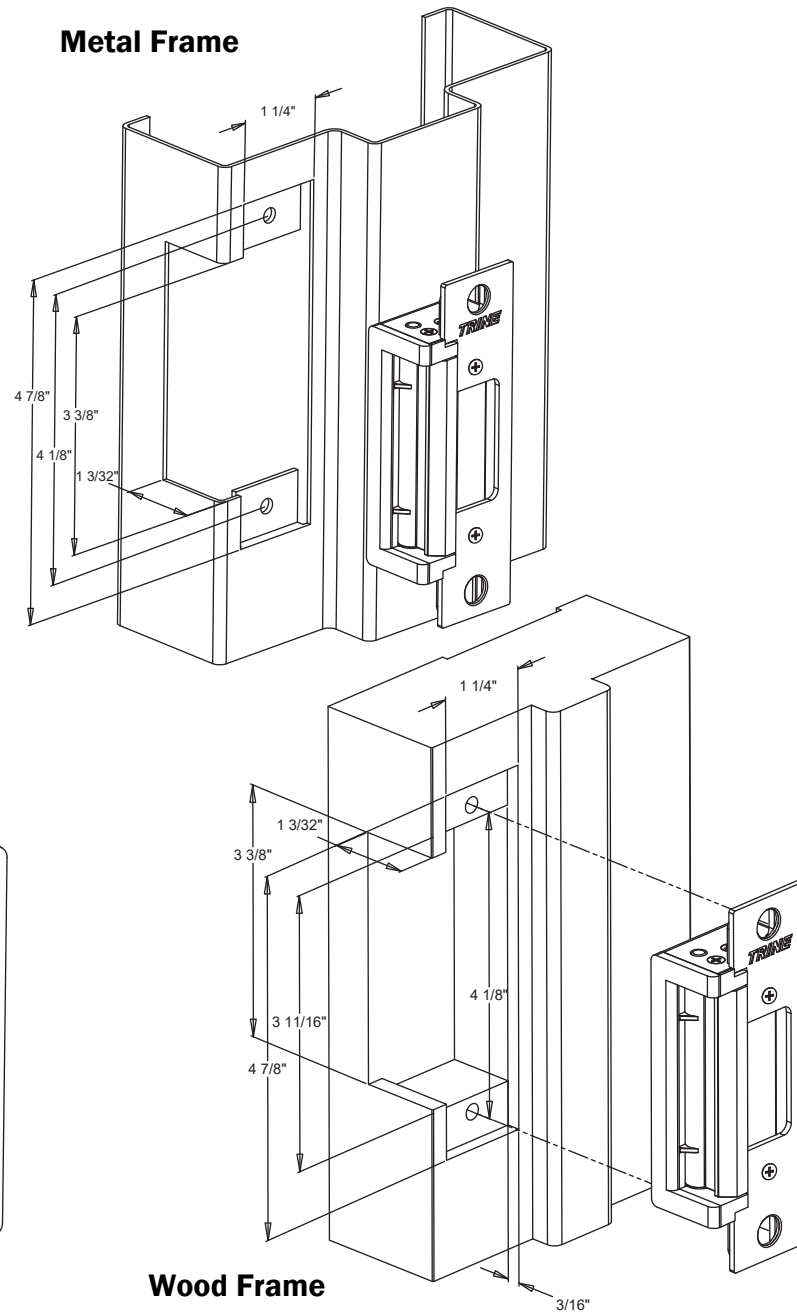

FACEPLATE DIMENSIONS

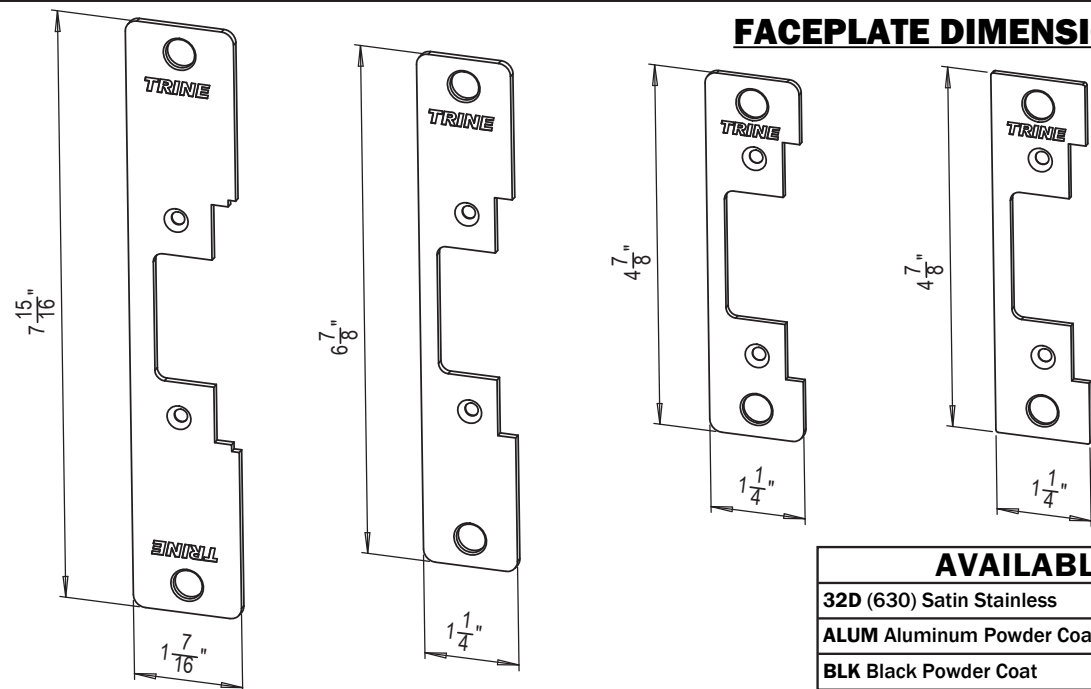

Important Note:

Tighten the faceplate mechanism screw very tightly to secure the position of the mechanism, in reference 16 inch-pound of torque.

AVAILABLE FINISHES

32D (630) Satin Stainless	DKBZ Dark Bronze Powder Coat
ALUM Aluminum Powder Coat	GRN Green Powder Coat
BLK Black Powder Coat	WHT White Powder Coat

RECOMMENDED PRE-INSTALLATION CHECK:

- Determine that the door swings without interfering with jamb or sill; the door must operate properly in order for the system to provide best results.
- The door must be equipped with a door closer, and the door closer "latch mode" must hold door in a completely closed position in order to avoid the lock latch from applying pressure against the releasing latch portion of the electric strike.
- Electrical wire connections must be completed and ready to be terminated inside the frame.
- Confirm that the power line in the frame is the correct voltage and that the switch works properly.
- Confirm proper clearance exists between the end of the lock latch and jamb.
- The faceplate opening used on the electric door strike must be centered with lock latch centerline when it is installed on the doorjamb.
- For best installation results, the door frame must be reasonably flat and straight.

INSTALLING THE 4300 STRIKE:

NOTE: The 4300 electric strike has two terminal wires to supply power to two separate solenoids.

- Prepare door frame as shown on page 2 (based on frame type).
- Pull the switched power wires to the door frame.

REMOVABLE FASCIA (Match the Color of the Frame)

The 4300 Fascia is designed to be replaceable and is available in 5 powder coat finishes. Replacing the Fascia is easy, follow these steps:

- Remove top and bottom assembly screws (see a.) from the electric strike, these hold the Fascia (see b.) in place.
- Fascia then slides away from the electric strike – note two additional holes (see c.) that provide stability to the Fascia.
- New Fascia is aligned to the holes and pushed in until screw holes align.
- Insert both the bottom and top assembly screws to secure the Fascia into the electric strike body.

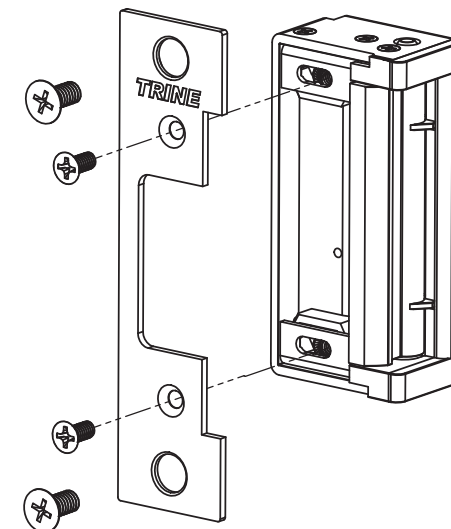

FACEPLATE ASSEMBLY

Faceplates and Longer Faceplates mount differently on the 4300 then on the 4200.

2 assembly holes to mount the faceplate to the electric strike.

2 holes for mounting the assembled faceplate/strike to the frame.

(Caution: Connect the power ONLY as the last step.)

- Carefully choose the quick connect socket to match the required voltage. The quick connect sockets are labeled 12VDC (Blue Wire) or 24VDC (White Wire).
- Use the crimp connectors to terminate the ends of the quick connect socket to the power wires coming out of the frame.
- Connect the strikes bottom terminal to the quick connect socket.
- Tuck the wires inside the door frame.
- Install the electric strike into the door frame
- Connect the power supply and turn power on.
- Test your system.

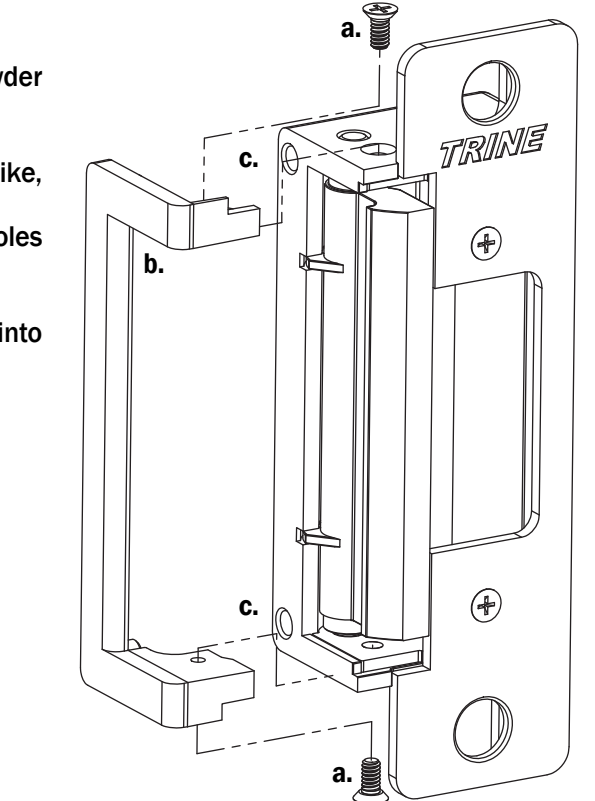
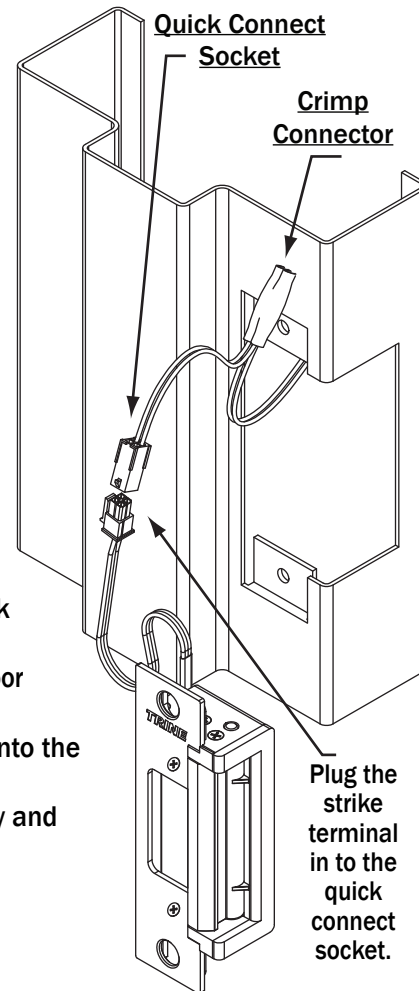

Available in 5 powdercoat finishes: Aluminum (ALUM), Black (BLK), Dark Bronze (DKBZ), Green (GRN), and White (WHT) which can match the finish of the faceplate and trim skirts.