

# Architectural Door Accessories

**ASSA ABLOY**

## PemkoHinge®

The global leader in  
door opening solutions

Applies to the following product:

**\_FM\_SLF**

*Continuous Geared Hinge*

**Standard Duty  
Full Mortise  
6" Between Bearing Centers**

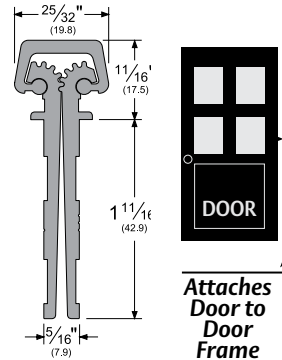

### Attributes:

#### PemkoHinge® Attributes:

- With a continuous hinge, typical alignment problems, such as door sag and binding, are eliminated. Unlike conventional hinges, the continuous hinge distributes load stress uniformly along the full length of the door and frame.
- The gear design of the continuous hinge ensures identical operation of each leaf; therefore, very little effort is required to open heavy commercial doors.
- Continuous hinge installation screws are located along the full length of the hinge, thereby preventing warping of the door along the hinge jamb.
- The continuous hinge acts as reinforcement for both door and frame.
- A high degree of security can be achieved for exterior openings or restricted spaces by using a continuous hinge. With the geared construction and the full-length channel cap, the common gap between the door and frame is sealed, which provides security against prying.
- In addition, the closing of this gap protects against pinching fingers in doors in public areas, particularly those where children are present.
- Sightproof design of the continuous hinge provides privacy for lavatories, executive offices, or file rooms.
- PemkoHinge® products are GUARANTEED FOR THE LIFE OF THE OPENING against defects in material or workmanship with the exception of residential and aluminum hinges which carry a 10 year warranty.

#### Standard Duty Full Mortise-Short Leaf Flush:

- Designed for use with doors which range between 1-3/4" to 2-1/4". Designed for use with hollow metal frames where the inset conforms to S.D.I. specifications for aligning doors and frames.
- Applied to conceal both leaves.

#### Why PemkoHinge® ?

- Tested and certified with the best warranty in the industry.
- No restrictions on frame gauge and wall conditions.
- No restriction on cutting hinges in field.
- No special cutting instructions or voided warranties.
- No special door and frame preps up to and including 90 minute doors.

### Product / Available Finishes:

**BLFMSLF** Black Anodized Aluminum  
**DFMSLF** Dark Bronze Anodized Aluminum  
**PWFMSLF** Painted White Aluminum

**CFMSLF** Clear Anodized Aluminum  
**GFMSLF** Gold Anodized Aluminum  
**SNFMSLF** Satin Nickel Anodized Aluminum

### Testing/Ratings:

Aluminum continuous hinge for use on swinging type fire doors of the hollow metal, tin-clad, sheet metal and steel covered composite type rated up to 3 hours, wood covered composite type rated up to and including 1-1/2 hours. Also wood core rated up to and including 20 minutes without hose stream. Meet criteria of UBC 7.2 for positive pressure.



LISTED  
Door Hinges  
76Y2

# Architectural Door Accessories

**ASSA ABLOY**

## PemkoHinge®

The global leader in  
door opening solutions

### Installation Instructions:

Full Mortise units are designed mainly for new doors and frames, and are applied so as to conceal both leaves. In retrofit applications, the door width must be reduced for proper clearance as shown in Figures A & B (below).

1. With the hinge leaves open, position the hinge against the frame rabbet. Be sure the leaf alignment flange is tight against the face of the frame. Allow 1/8" between the frame header and the top of the hinge leaf for door clearance. Mark and drill the top two holes per Drill Size Chart (below). **(Do not install).**
2. Position the door leaf of the hinge on the door. Be sure that the door leaf alignment flange is seated along the full length of the door edge, and the top edge of the door leaf is flush with the top edge of the door. Mark and drill all holes per Drill Size Chart. Thread tapping not required.
3. Screw the door leaf portion of the hinge to the door using the 12-24x7/16" thread forming screws. (Use wax or soap on screws to aid installation.)
4. Position the door at 90° to the frame. Install the top two screws in the frame leaf.
5. Close door and inspect for proper clearance and fit. Make adjustments as required due to improper frame installation if necessary to ensure proper operation of the complete assembly.
6. Mark and drill remaining frame leaf holes per Drill Size Chart, and install remaining screws.
7. FirePins are required on 3 hour (A-Label) assemblies. (See next page for instructions).

### Shortening the Hinge:



If the PemkoHinge® must be shortened, cut the bottom only using a chop saw. This will allow metal chips to work out after the installation. Although the PemkoHinge® is not handed, the hinge becomes handed after cutting and the cut edge must be installed at the bottom of the opening.

### Drill Size Chart:

MATERIAL	THICKNESS	DRILL SIZE
Aluminum	.090 - .140	13
Metal	20 gauge	17
Metal	16-18 gauge	15
Metal	12-14 gauge	13
Wood	N/A	5/32"

### Figures:

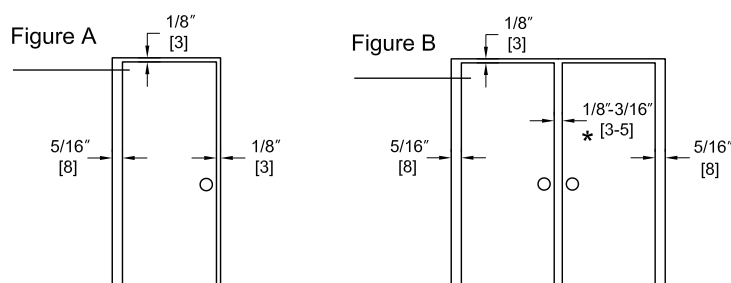

\* Allow extra clearance as required per astragal manufacturer.

### Testing/Ratings:

Aluminum continuous hinge for use on swinging type fire doors of the hollow metal, tin-clad, sheet metal and steel covered composite type rated up to 3 hours, wood covered composite type rated up to and including 1-1/2 hours. Also wood core rated up to and including 20 minutes without hose stream. Meet criteria of UBC 7.2 for positive pressure.



LISTED  
Door Hinges  
76Y2

## PemkoHinge®

The global leader in  
door opening solutions

### Fire Pins:

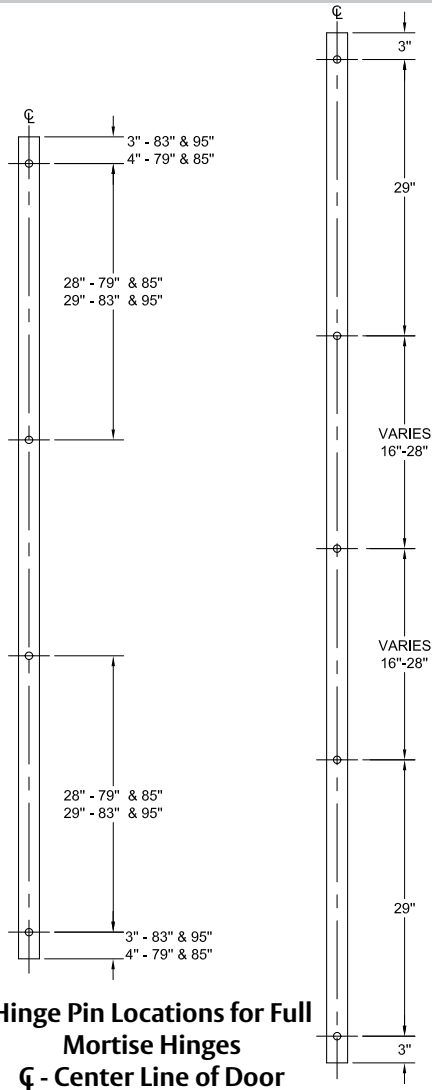

### FIRE PINS ARE REQUIRED ON 3 HOUR RATED DOORS ONLY

#### PIN INSTALLATION:

Full Mortise (Edge Mounted) Hinge:

Install PemkoHinge® on door and frame prior to locating pins.

1. Drill and tap for 5/16-18 threads in frame as indicated on the template or the drilled frame leaf of the PemkoHinge®.
2. Insert Firepin in threaded hole.
3. Drill 3/4" hole 1/2" deep in edge of door where indicated on the template or the drilled door leaf of the PemkoHinge®.

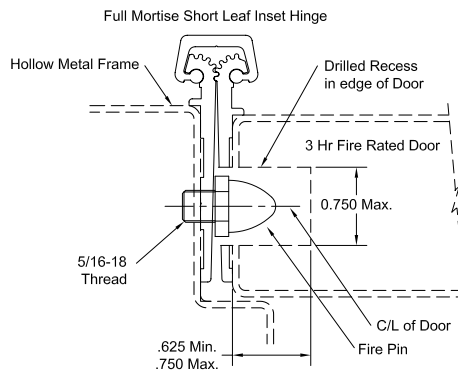

### Testing/Ratings:

Aluminum continuous hinge for use on swinging type fire doors of the hollow metal, tin-clad, sheet metal and steel covered composite type rated up to 3 hours, wood covered composite type rated up to and including 1-1/2 hours. Also wood core rated up to and including 20 minutes without hose stream. Meet criteria of UBC 7.2 for positive pressure.



LISTED  
Door Hinges  
76Y2

### Tools Required:

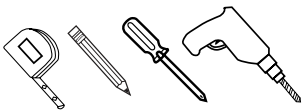

[www.pemko.com](http://www.pemko.com)

MEMPHIS, TN USA    VENTURA, CA USA    VANCOUVER, BC CA    TORONTO, ON CA  
P: 800 824-3018    P: 800 283-9988    P: 877 535-7888    P: 877 535-7888  
F: 800 243-3656    F: 800 283-4050    F: 877 535-7444    F: 877 535-7444

Copyright © 2017 Pemko Manufacturing Co., an ASSA ABLOY Group company. All rights reserved.  
Reproduction in whole or in part without the express written permission of Pemko Manufacturing Company is prohibited.