

1406/1426 POWER SUPPLIES



ACSI 1406 and 1426 Power Supplies are designed to operate exit devices equipped with **ACSI Series 1550 Electric Latch Retraction**.

Features

- UL Listed and tested to UL 294 standard for access control system units
- Class 2 rated outputs
- Overload, over voltage and short circuit protection
- 1406 Series only: Select from independent control of single exit devices from separate inputs (one or two single doors) or sequential operation of two exit devices from a single input (pair of doors)
- Automatic door operator interface
- Fire alarm interface
- Field adjustable latch retraction time delay
- 24VDC, 12VDC* constant voltage outputs (250mA each)

*Not available in battery backup models

Day/Night Mode-ACSI 1426 Power Supply

Provides a separate input for retracting one exit device or two exit devices sequentially without activating the automatic door operator. While the latches are held retracted, the auto-operator can be activated independently from a different input.

1406BB/1426BB Power Supplies with battery backup

All the same features as above, but includes built-in battery backup power:

- 4 hours of backup power at full load during AC power failure
- Standby battery power with a supervised AC failure output and low battery output
- Supplied with (2) 12V@7AH lead acid batteries

ACSI 1406 Application

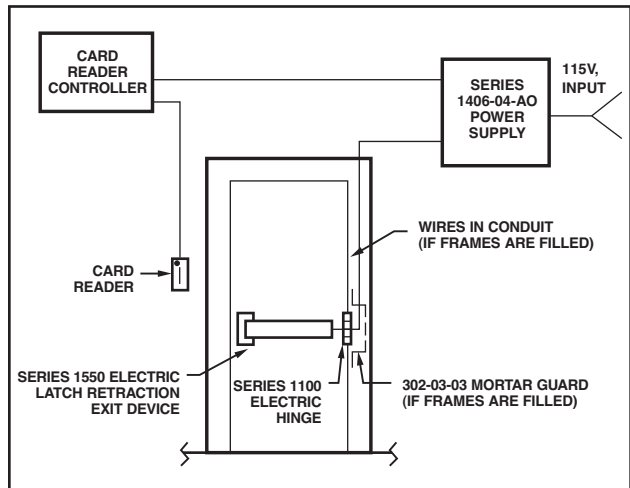

ACSI 1426 Application with Day/Night Feature

