

# 0147 PIVOT SET, 3/4" OFFSET, HANDED

## 0147 BOTTOM PIVOT

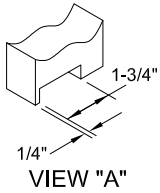
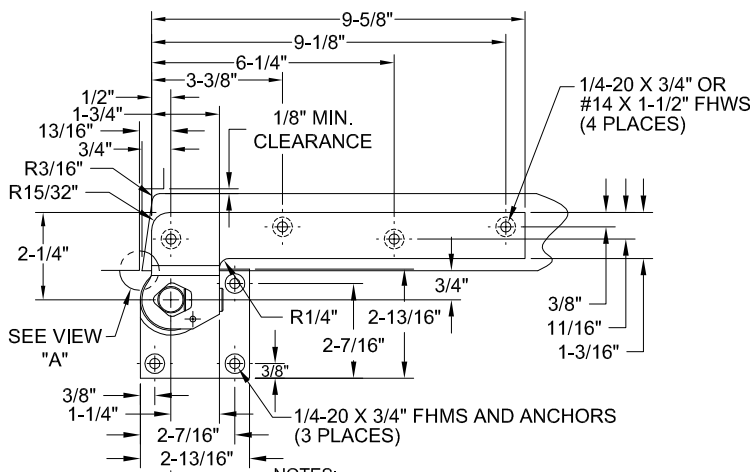

### NOTES:

1. PIVOTS DRILLED FOR 1/4-20 FHMS OR #14 FHWS.
2. REINFORCING BY OTHERS.
3. IT IS THE DOOR AND FRAME MANUFACTURERS RESPONSIBILITY TO CHECK THE HARDWARE SCHEDULE AND PREP THE DOORS AND FRAMES.
4. MAXIMUM DEGREE OF OPENING, 180°, TRIM PREMITTING.
5. RIGHT HANDED SHOWN.

## 0180 TOP PIVOT

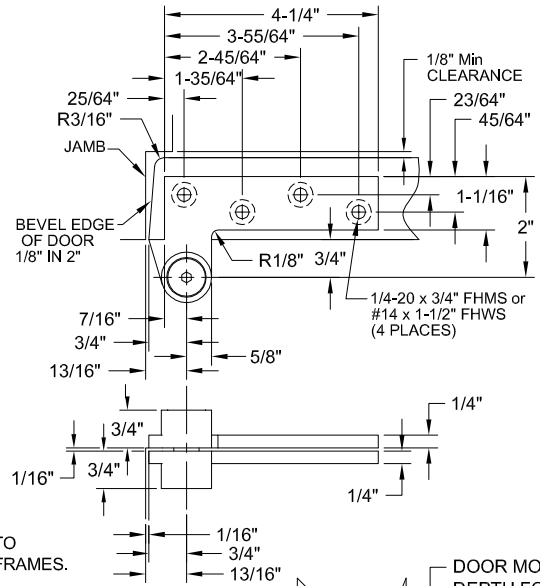

DOOR MORTISE "A" DEPTH FOR ARM

	"A"
1/4" THRESHOLD	7/8"
1/2" THRESHOLD	5/8"

FINISHED FLOOR

WITH THRESHOLD

## INSTALLATION INSTRUCTIONS

1. MEASURE 13/16" OUT FROM DOOR JAMB.
2. ALLOW 1/8" MIN CLEARANCE FROM DOOR STOP TO DOOR FACE. MEASURE DOOR THICKNESS AND ADD 3/4".
3. WHERE THESE LINES INTERSECT DETERMINES THE CENTERLINE OF THE PIVOT POINT.
4. FLOOR PORTION MUST BE INSTALLED COMPLETELY LEVEL IN BOTH DIRECTIONS PER ILLUSTRATION #1.
5. INSTALL 0180 DOOR PORTION PER TEMPLATE.
6. INSTALL 0180 JAMB PORTION PER TEMPLATE.
7. INSTALL 0147 DOOR PORTION PER TEMPLATE.
8. IF 019 INTERMEDIATE PIVOT IS USED, SEE 019 TEMPLATE.
9. SET DOOR ON 0147 FLOOR PORTION BEARING.
10. PUSH 0180 PIVOT PIN IN PLACE AND SECURELY TIGHTEN 0180 END CAP.
11. IF DOOR DRAGS AT FLOOR (OR THRESHOLD, IF USED) LOOSEN SET SCREW AND RAISE DOOR TO DESIRED CLEARANCE AND INSERT 1/16" THICK SHIM. RETIGHTEN SET SCREW SECURELY.
12. PUT 0147 COVER ON AND SECURE TIGHTLY WITH 0147 COVER SCREW.

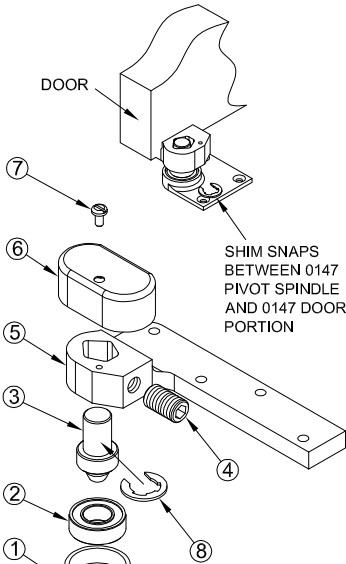
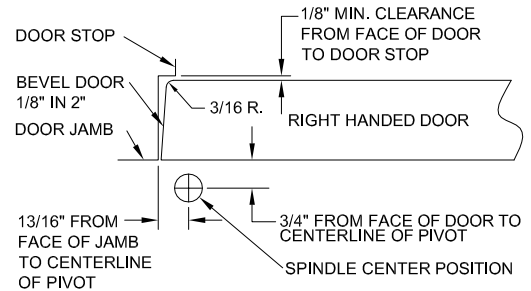

ITEM NO.	QTY.	PART NO.
1	1	0147 FLOOR PORTION
2	1	0147 BEARING
3	1	0147 PIVOT SPINDLE
4	1	0147 SET SCREW
5	1	0147 DOOR PORTION
6	1	0147 COVER
7	1	0147 COVER SCREW
8	1	1/16" SHIM (IF REQUIRED)

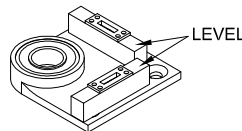
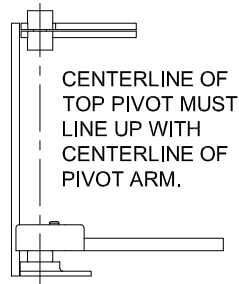
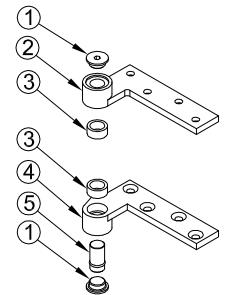

ILLUSTRATION #1



ITEM NO.	QTY.	PART NO.
1	2	0180 END CAP
2	1	0180 JAMB PORTION
3	2	0180 NEEDLE BEARING
4	1	0180 DOOR PORTION
5	1	0180 PIVOT PIN



® www.abhmfg.com  
 E-mail: abhinfo@abhmfg.com  
 Architectural Builders Hardware Mfg., Inc.  
 1222 Ardmore Ave., Itasca, IL 60143  
 630.875.9900; FAX 800.9FAXABH (932.9224)

© 2015 ABH Mfg., Inc.  
 printed in USA

0147-04.DWG

0147

PAGE 1 OF 1

REVISED 04-21-15